

T e c h n i c a l F u r n i t u r e
S y s t e m

Assembly Instructions 2010



scanmagnetics.com

 **Gesab**[®]
guarantee for the future

Assembly Instructions – Index

<i>Base Side Assembly Instructions</i>	<i>Chap. 1</i>
<i>Extensible Foot Assembly Instructions</i>	<i>Chap. 2</i>
<i>Frame Assembly Instructions</i>	<i>Chap. 3</i>
<i>Base Side + Frame Assembly Instructions</i>	<i>Chap. 4</i>
<i>Connecting Post Assembly Instructions</i>	<i>Chap. 5</i>
<i>Frame Joint Assembly Instructions</i>	<i>Chap. 6</i>
<i>Stabilizer Assembly Instructions</i>	<i>Chap. 7</i>
<i>Table Assembly Instructions</i>	<i>Chap. 8</i>
<i>Metal Tray Assembly Instructions</i>	<i>Chap. 9</i>
<i>Shelf Assembly Instructions</i>	<i>Chap. 10</i>
<i>Corner Table and Shelf Assembly Instructions</i>	<i>Chap. 11</i>
<i>Duct Assembly Instructions</i>	<i>Chap. 12</i>
<i>19" Support Kit Assembly Instructions</i>	<i>Chap. 13</i>
<i>19" Socket Base Assembly Instructions</i>	<i>Chap. 14</i>
<i>19" Duct Assembly Instructions</i>	<i>Chap. 15</i>
<i>19" Rack Compartment Assembly Instructions</i>	<i>Chap. 16</i>
<i>Compartment Assembly Instructions</i>	<i>Chap. 17</i>
<i>19" Rack Side Assembly Instructions</i>	<i>Chap. 18</i>
<i>Wall Rack Assembly Instructions</i>	<i>Chap. 19</i>
<i>Panel Assembly Instructions</i>	<i>Chap. 20</i>
<i>TFT Support Assembly Instructions</i>	<i>Chap. 21</i>
<i>Console Assembly Instructions</i>	<i>Chap. 22</i>
<i>Console Side Assembly Instructions</i>	<i>Chap. 23</i>
<i>Console Shelf Assembly Instructions</i>	<i>Chap. 24</i>
<i>Console Compartment Assembly Instructions</i>	<i>Chap. 25</i>
<i>ATS Assembly Instructions</i>	<i>Chap. 26</i>

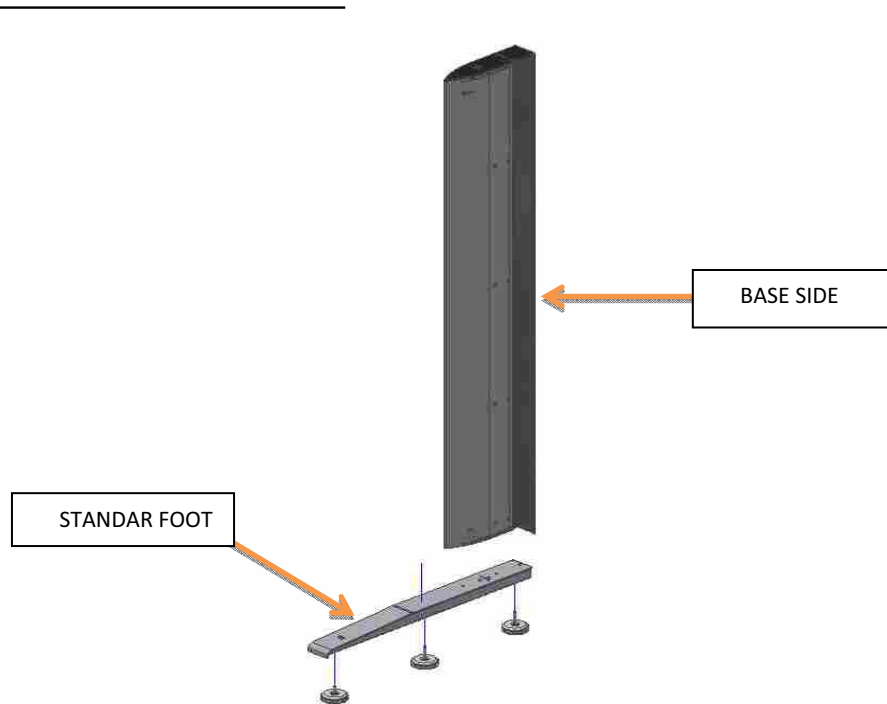

Fig 1

Assembly process Graphic assembly process

i The **side** must be assembled horizontally, i.e. lying on the floor.

STEP 1 – Position the **foot** in the bottom of the **side**. (Fig. 2)

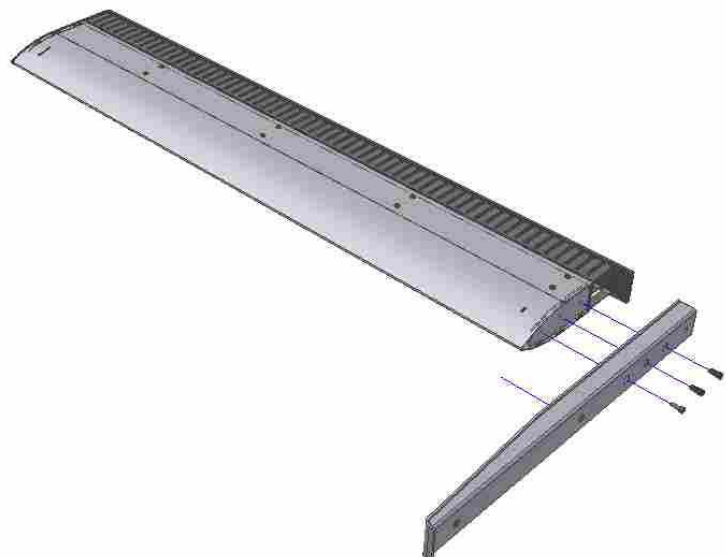
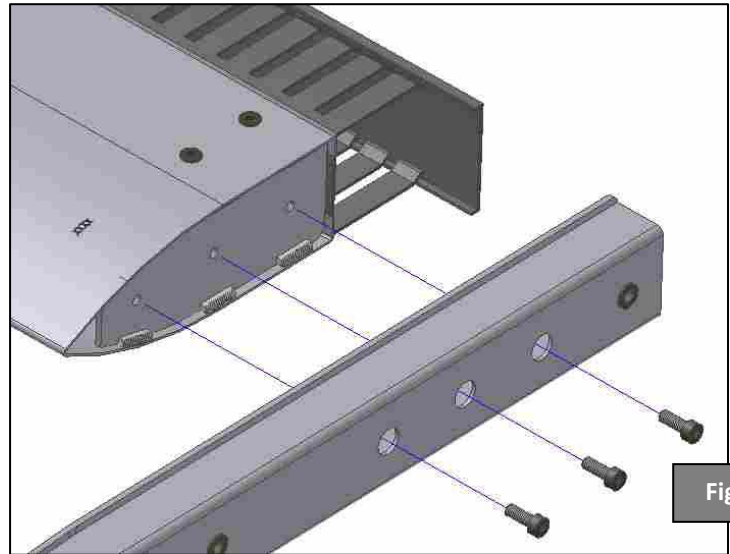
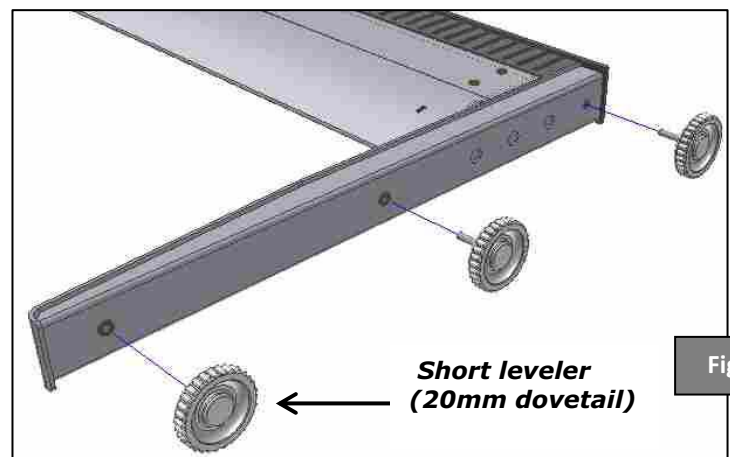

Fig 2

STEP 2 – Screw the **standard foot** tightly on to the **side** with 3 **M8x20 DIN 912 Allen screws + M8 Grover washer** (Fig.3).



STEP 3 – Screw the **levelers** on to the **foot** rivets. Mount the **short leveler**, i.e. the **leveler with 20mm dovetail**, on the front of the **foot**. (Fig. 4)



MOBILE SIDE: The only difference in the **mobile base side** is that the **levelers** are replaced by two **wheels**. (Fig. 5)

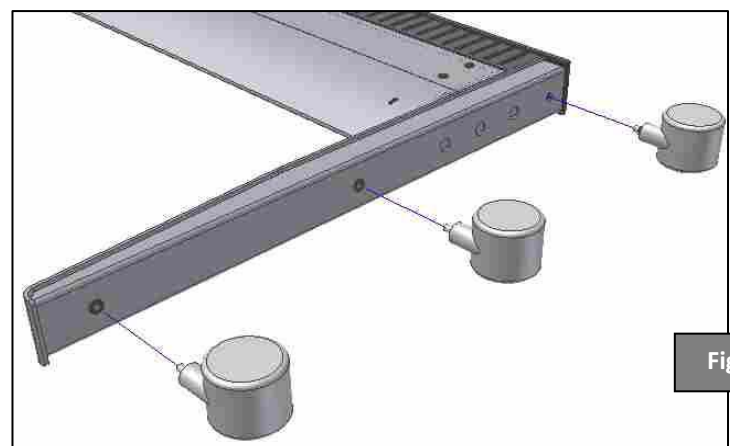

Extensible Foot Assembly Instructions

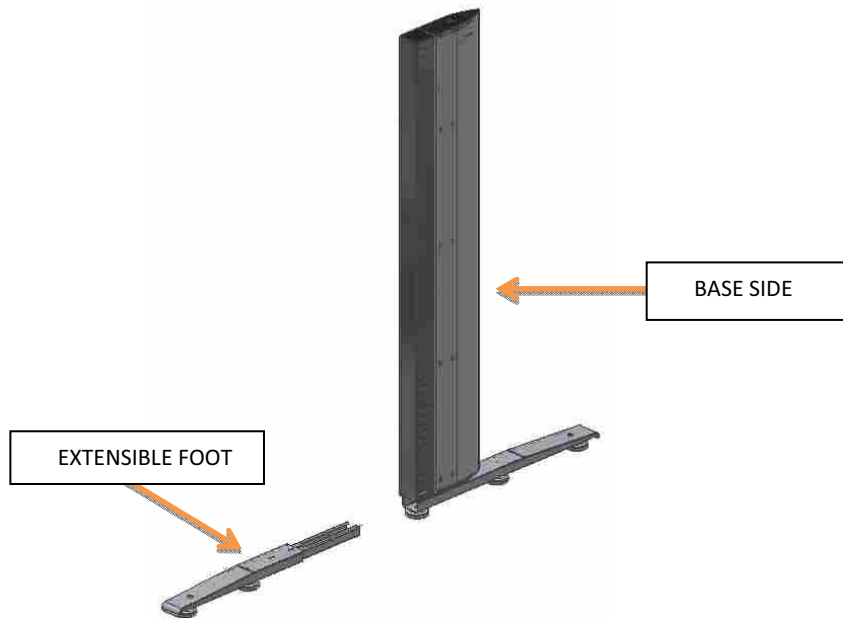

Fig 1

Assembly process | Graphic assembly process



The **extensible foot = two-sided foot**. It can be later assembled in any extension arrangement.

STEP 1 – Before mounting the **extensible foot**, remove the cover from the **vertical wiring duct** of the **base side** (Fig. 3). To mount the **foot**, cut 40mm from the bottom of the PVC cover (Fig.2).

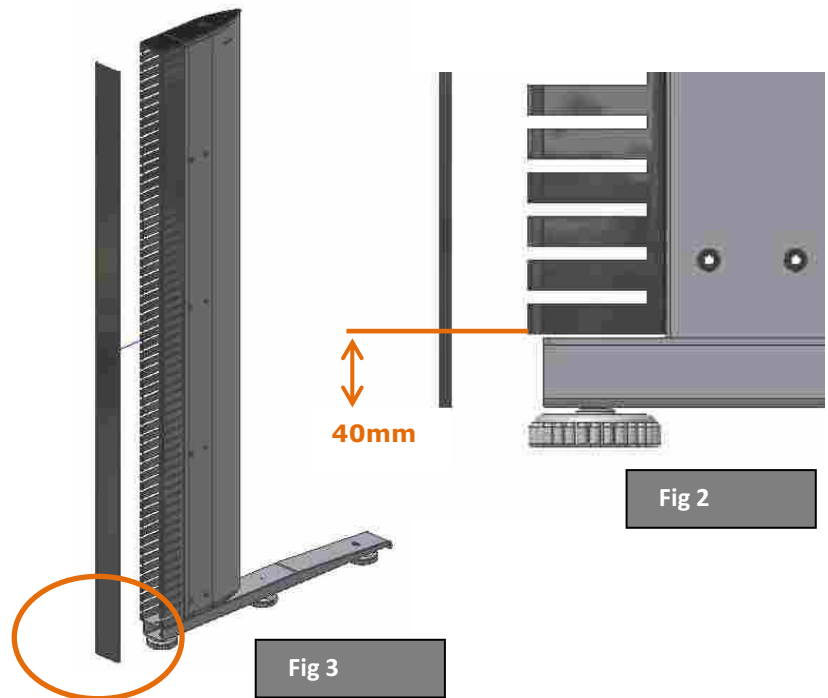
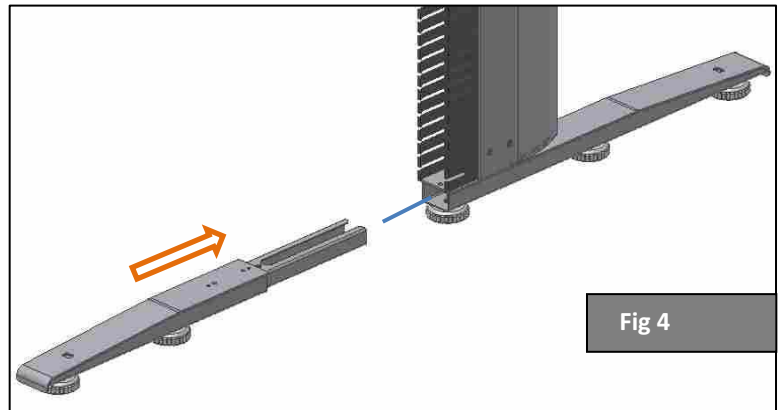

Fig 2

Fig 3

STEP 2 – Position the **extensible foot** behind the **standard foot** and insert it fully (Fig.4).



STEP 3 – Screw both **feet** in with a single **M8x20 DIN 912 Allen screw** (Fig. 5 and 6).

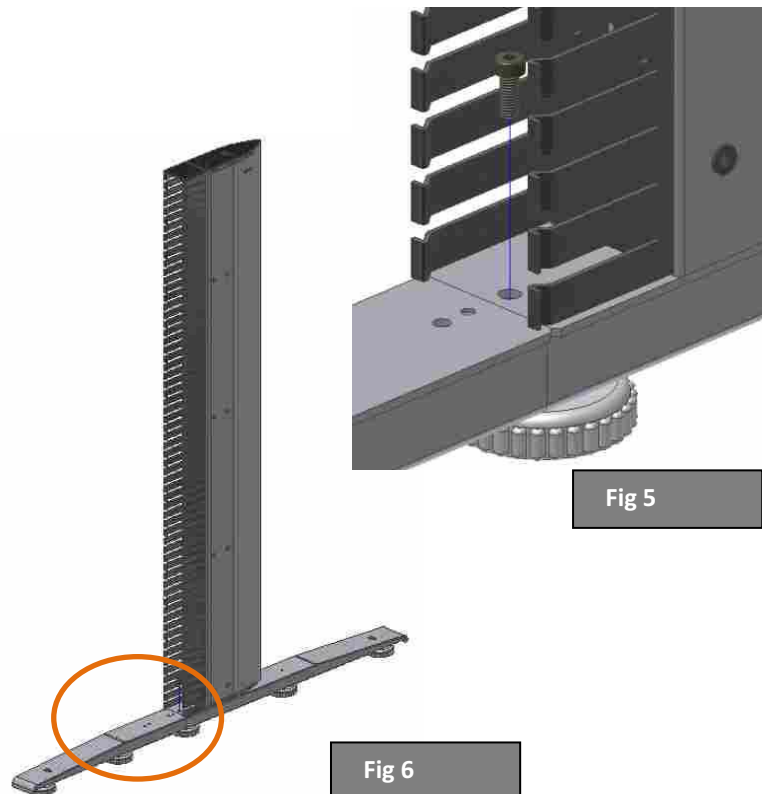

STEP 4 – Replace the cut section of the PVC cover on the **vertical wiring duct** of the **base side** (Fig. 7).

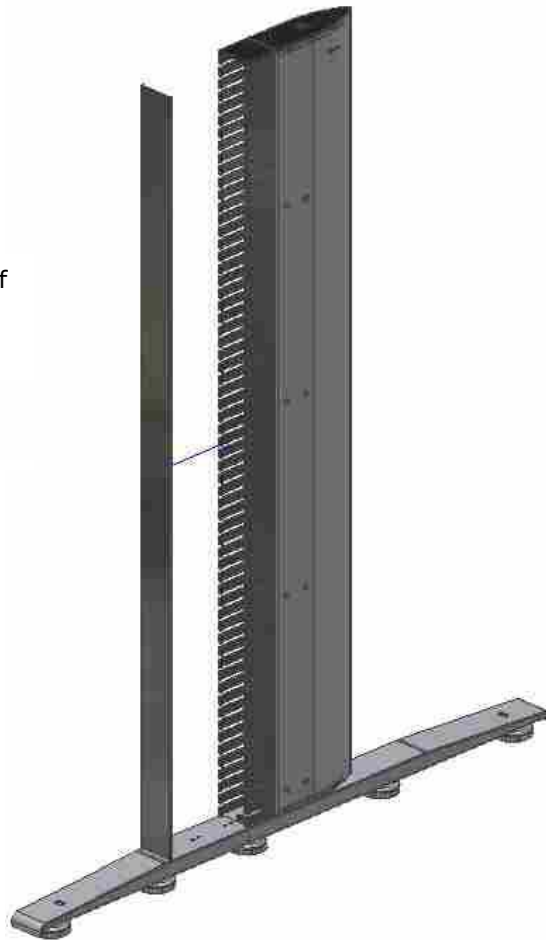

Fig 7

STEP 5 – Adjust the height of the **side** using the **levellers** of both **feet** (Fig. 8).

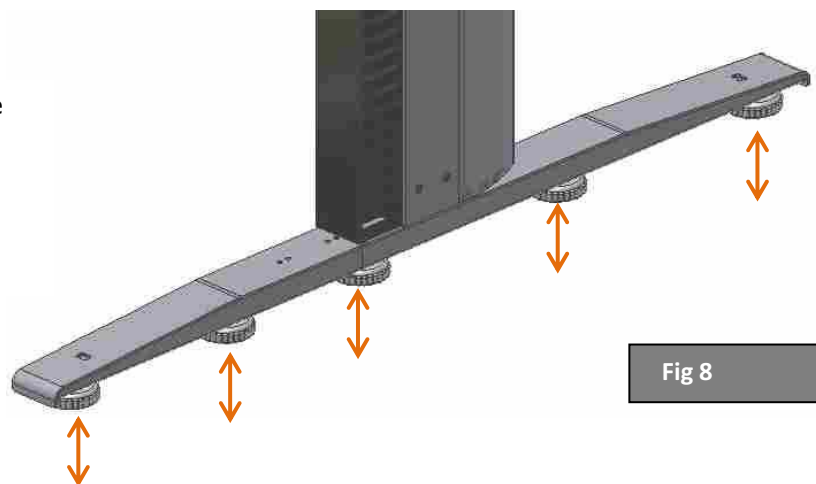

Fig 8

Frame Assembly Instructions

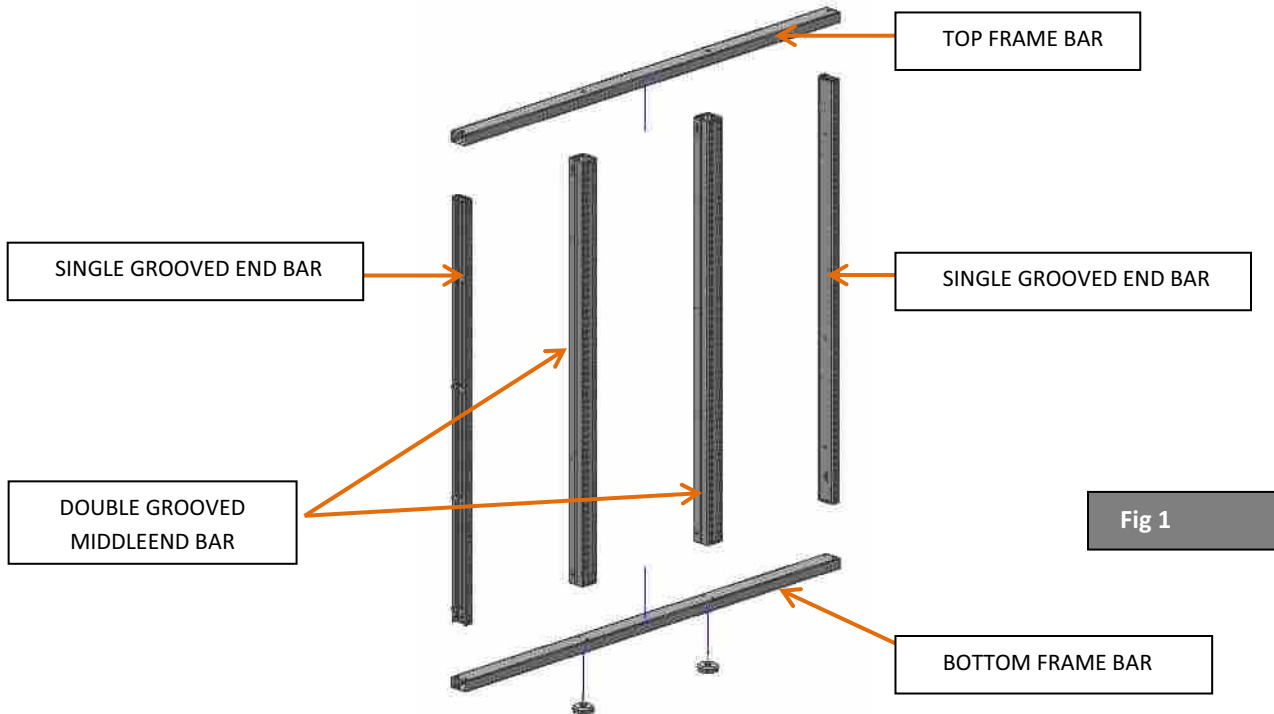

Fig 1

Assembly process

Graphic assembly process



The **frame** must be assemble horizontally, i.e. lying on the floor.

Frame Width	N° double grooved middle bars
600	-
800	-
1200	1
1600	1
1800	2
2400 (600)	3
2400 (800)	2

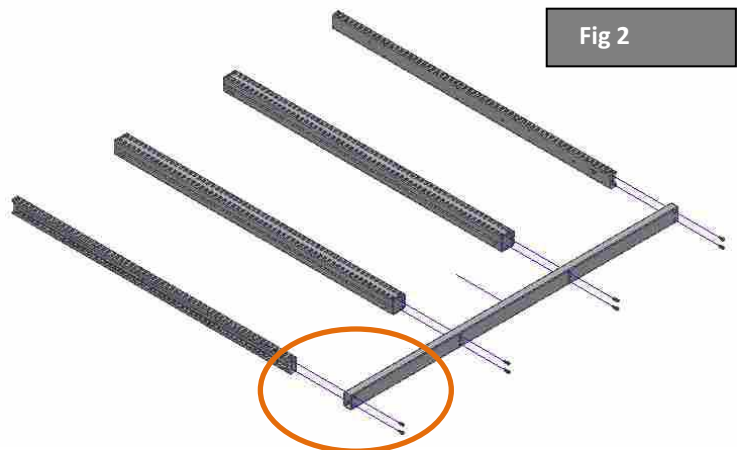

Fig 2

STEP 1 – Position the **grooved bars** (the wide part of the groove must be facing upwards and the narrow part downwards) and the bottom bar (Fig. 2).

STEP 2 – Screw the **bottom bar** to the grooved bars with 2 **M8x20 DIN 912 Allen screws + M8 Grover washer** for each bar (Fig. 3).

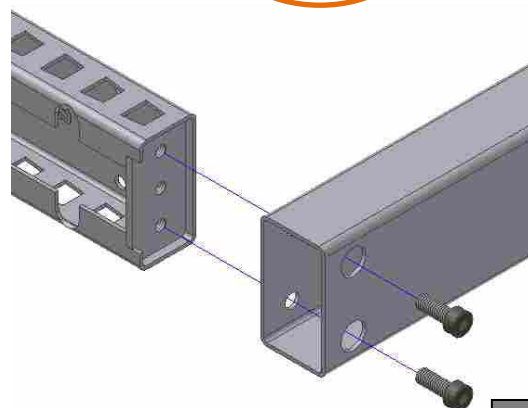
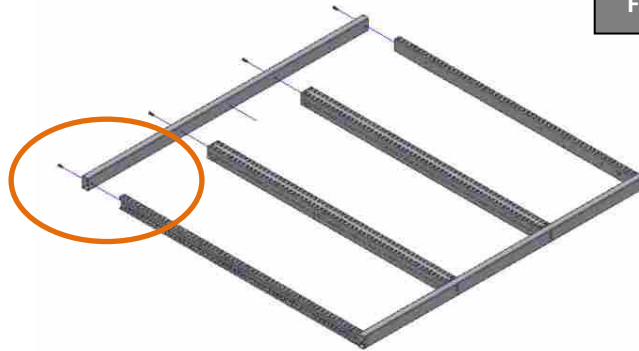

Fig 3

Fig 4

STEP 3 - Position the **top bar** on the **frame** (Fig. 4)



STEP 4 - Screw the **top bar** to the **grooved bars** with 1 **M8x20 DIN 912 Allen screw + M8 Grover washer** for each **bar** (Fig. 5).

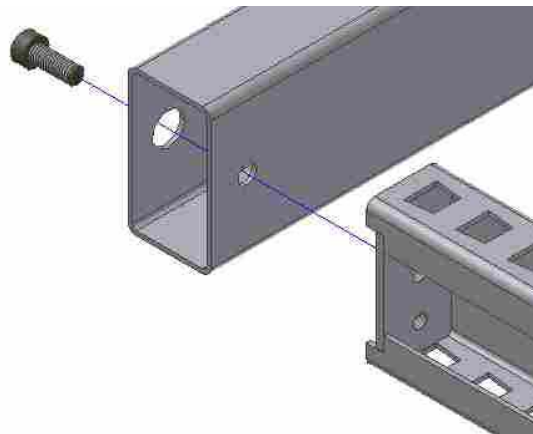

Fig 5

STEP 5 - Check one of the two **frame** measurements shown below (Fig.6).

d1= inside **frame** measurement or
d2 = measurement between
trapezoids of the **grooved bars**.

For 600mm sections:

d1= 530mm

d2 = 565mm

For 800mm sections:

d1= 730mm

d2 = 765mm



It is important to ensure this measurement is correct because the correct assembly of the accessories depends on it.

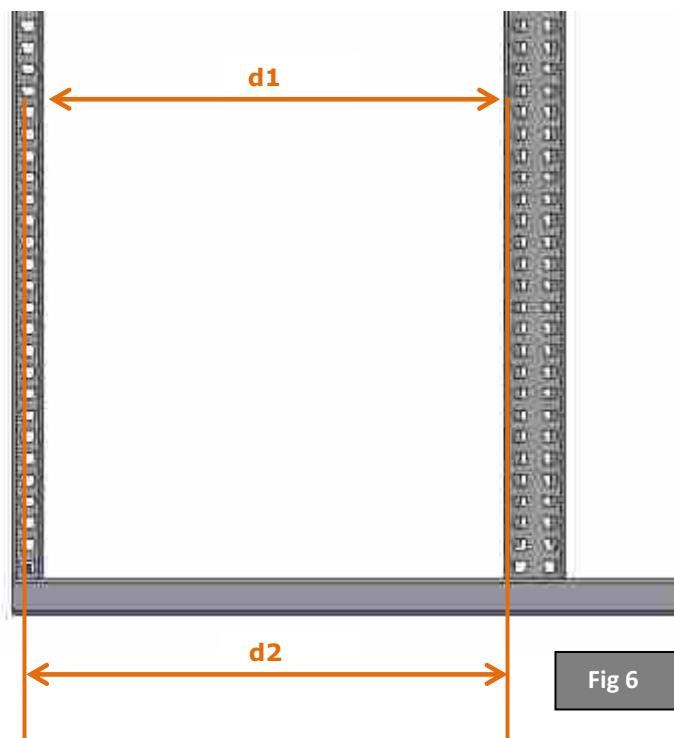
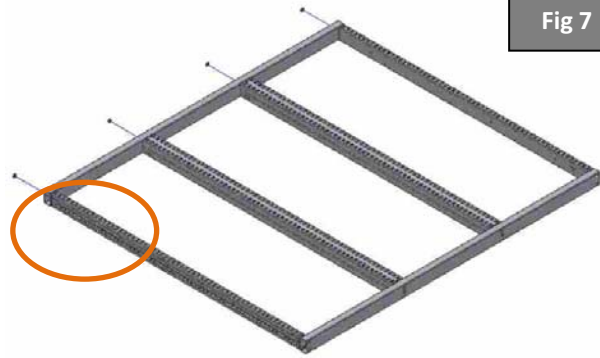
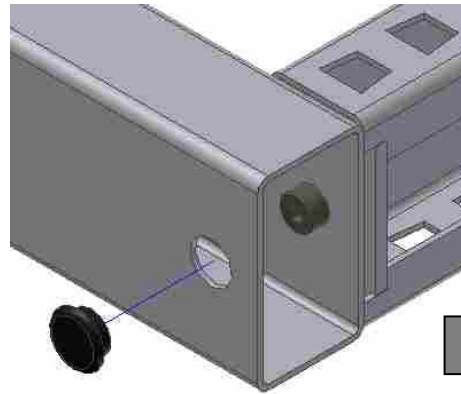

Fig 6

Fig 7



STEP 6 – Position the plugs in the holes of the **top bar** (Fig. 7 and 8).



Fig

Fig 9

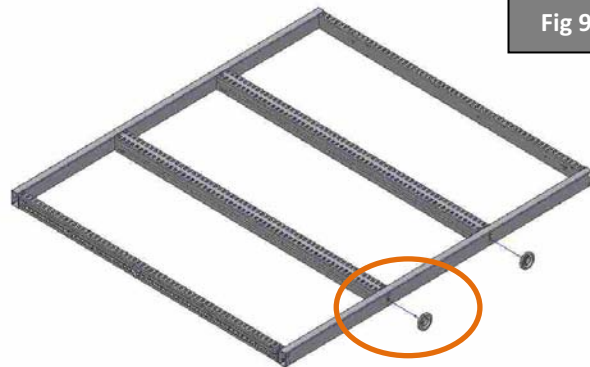

STEP 7 – Screw the **levellers** onto the rivets of the **bottom bar** (Fig. 9 and 10).

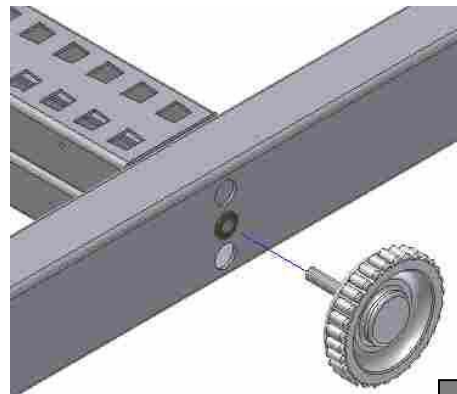

Fig 10

MOBILE FRAME:

The only difference in the **mobile base frame** is that the **levellers** are replaced by **wheels** (Fig. 11).

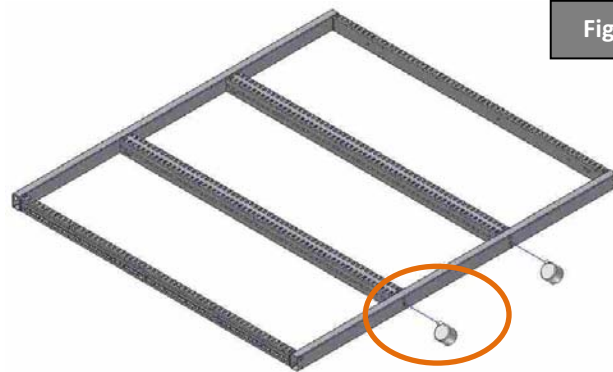

Fig 11

STEP 7b – Screw the **wheels** on to the rivets of the **bottom bar** (Fig. 12).

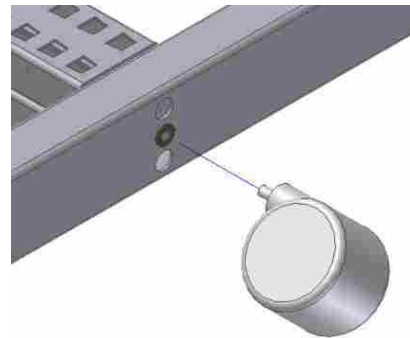

Fig 12

PANEL FRAME:

The only difference between the **frames** is the replacement of the **top bar** (tube) for a U-shaped profile. The plugs of Step 6 do not need to be placed.

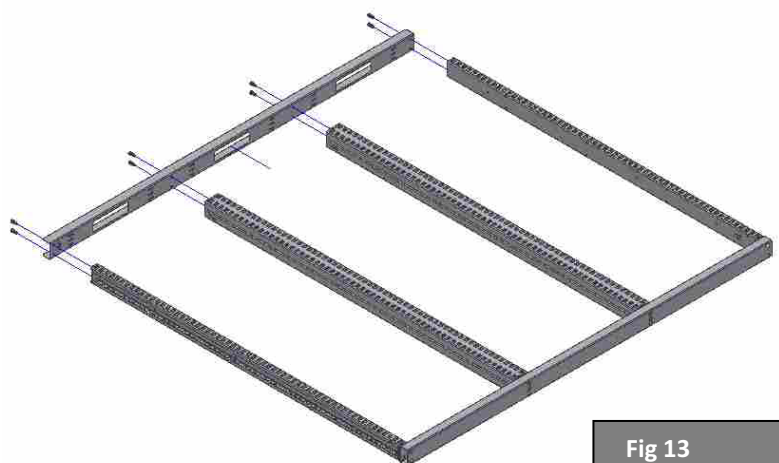

Fig 13

STEP 3b – Position the top U-shaped profile on the **frame** (Fig. 13).

STEP 4b – Screw the **top profile** to the **grooved bars** with 2 **M8x20 DIN 912 Allen screws** (Fig. 14)

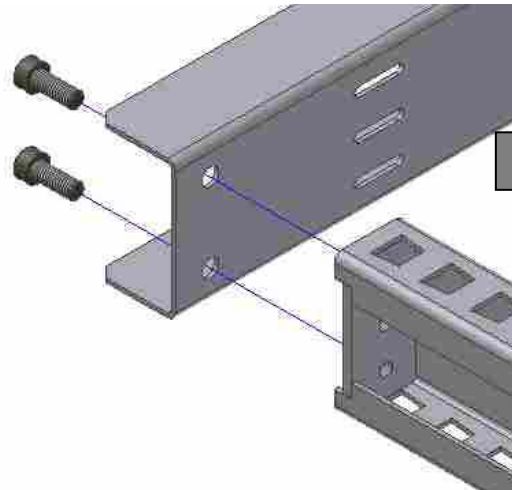

Fig 14



The only **frame** height in which **panels** are not mounted is 740mm.

STRAIGHT CONSOLE FRAME:

The only difference between **frames** is the replacement of the 40mm high **top bar** (tube) by a 10mm C-shaped profile. The plugs of Step 6 do not need to be placed.

STEP 3c – Position the C-shaped profile on the **frame** (Fig. 15).

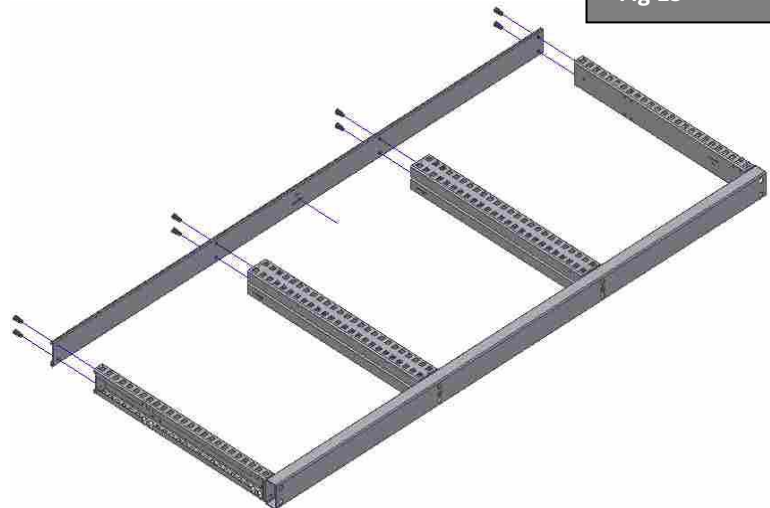

Fig 15

STEP 4c - Screw the **top profile** to the **grooved bars** with 2 **M8x20 DIN 912 Allen screws** (Fig. 16)

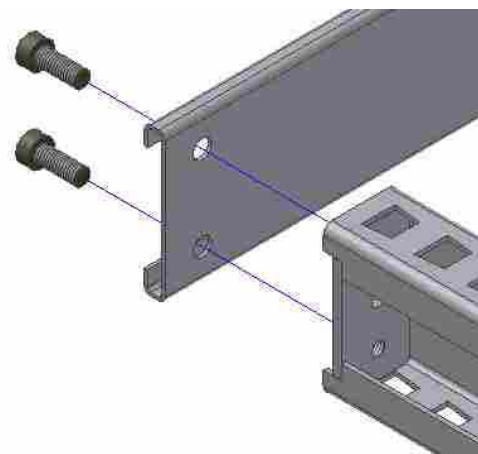

Fig 16



There is only one height in the **console frame: 740mm**

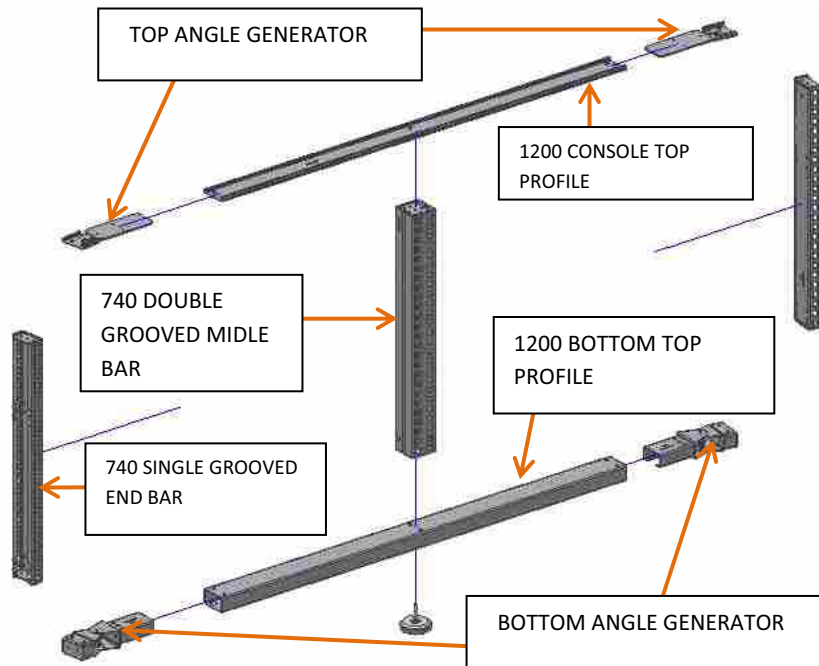

Fig 17



The **angle frame** starts from the base of the **1200 straight frame (607-2-1210)**. There is only one height in the **console frame: 740mm**.

STEP 1 – Assembly of the “I” body of the **frame**: position the **1200 console top profile** and the **1200 bottom frame bar** on the **740 middle double bar** (Fig. 18).

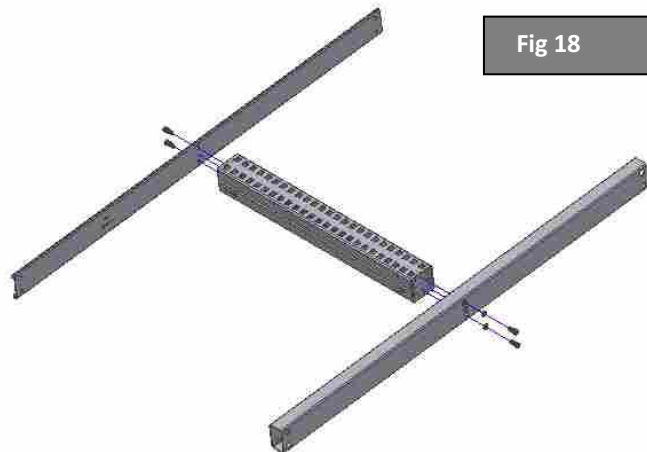
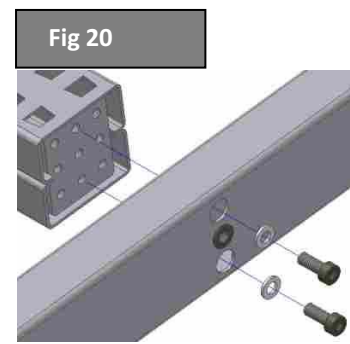
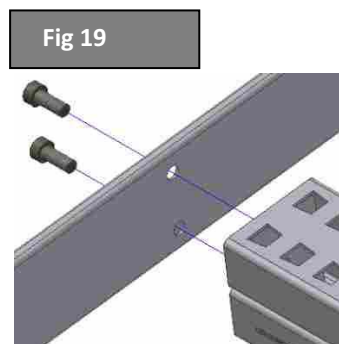

Fig 18

The wide part of the groove of the **middle bar** must be facing upwards and the narrow part downwards (Figs. 19-20)

Screw at the top with 2 **M8x20 DIN 912 Allen screws** (Fig. 19). At the bottom, the same but adding **2 ø8 Grover washers** (Fig. 20).



STEP 2 – Screw the **leveller** to the rivet of the **bottom bar** (Fig. 21)

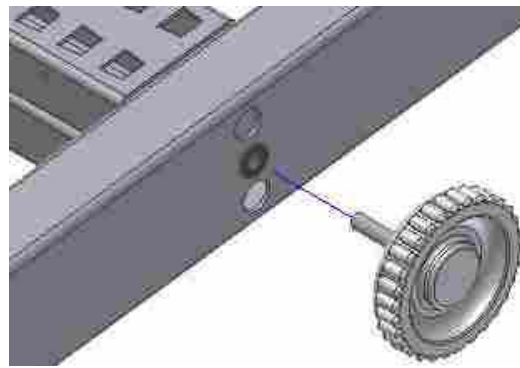

Fig 21

STEP 3 – Join the **generator** to the **frame**, both on the **top profile** and on the **bottom bar** (Fig.22)

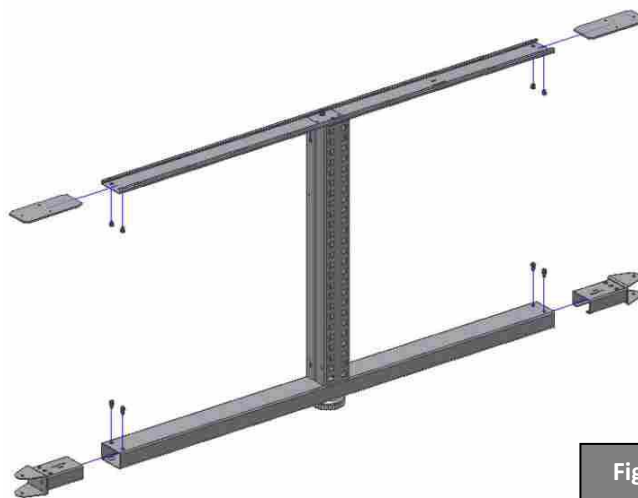

Fig 22

At the top, insert the **generator plate** in the **profile** and screw at the bottom with **2 M6x10 ISO 7380 Allen screws** (Fig. 23).

At the bottom, insert the **female generator** into the **bar** and screw at the top with **2 M6x16 ISO 7380 Allen screws** (Fig. 24).

Fig 23

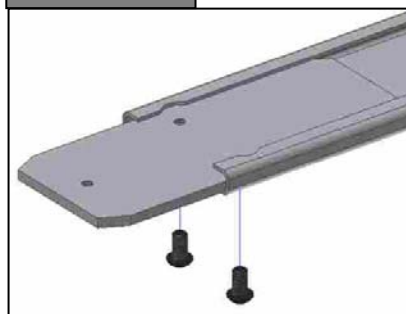
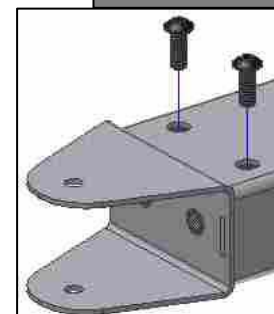

Fig 24



STEP 4 – Join the **generator** to the **bar**, both at the top and the bottom (Fig.25)

At the top, mount the **generator profile** to the **bar** and screw it on with **2 M8x20 DIN 912 Allen screws** (Fig. 26).

At the bottom, mount the **male generator** to the **bar** and screw it on with **2 M8x20 DIN 912 Allen screws + ø8 Grover washers** (Fig. 27)

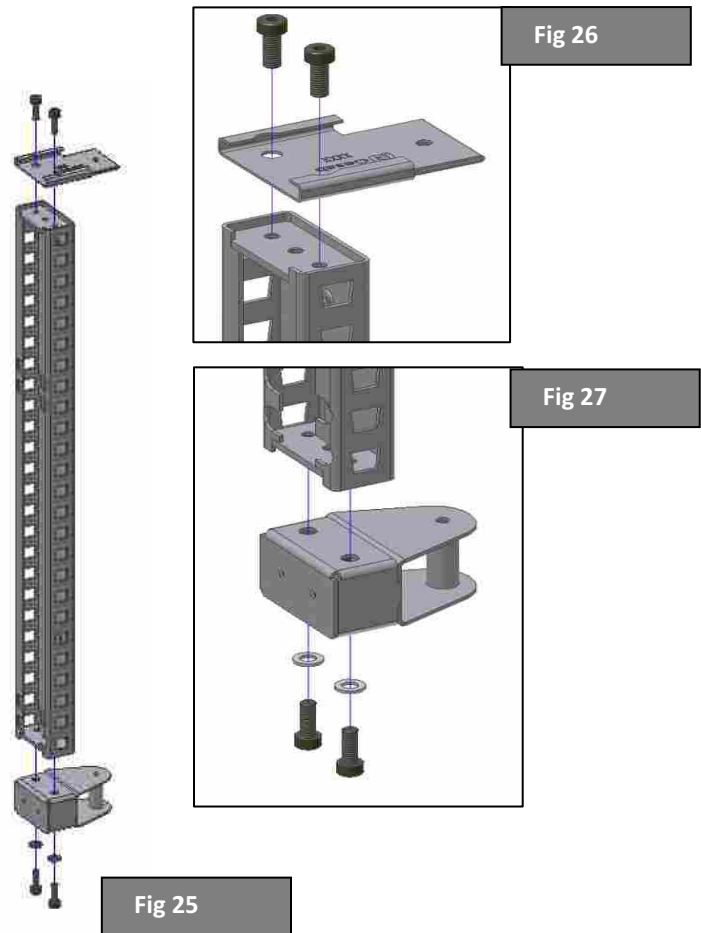

STEP 5 – Assemble the **740 single end bar** to the **"I" frame**, i.e. join the two parts of the **generator** (Fig. 28)

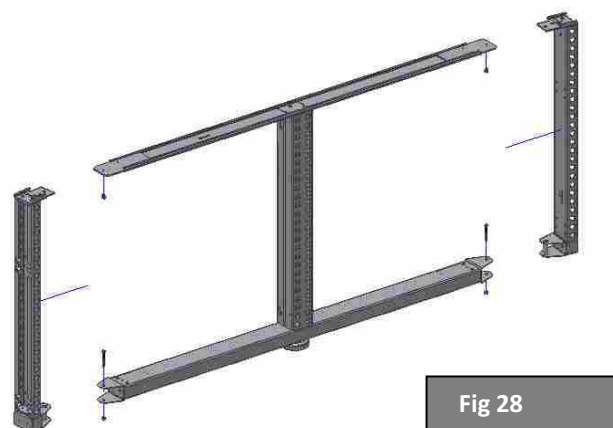

At the top, screw both parts of the **generator** (plate and profile) from below with **1 M6x10 ISO 7380 Allen screw** (Fig. 29).

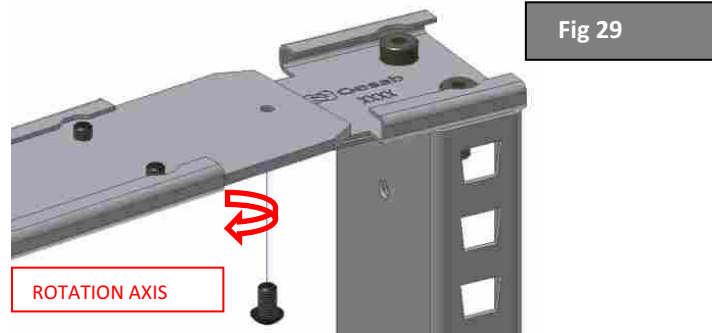

At the bottom, assemble both parts of the **generator**; screw from above with **1 M6x55 ISO 7380 Allen screw** and **M6 DIN785 lock nut** (Fig. 30)



The latter will be tightened once the angle with the **tray** has been adjusted.

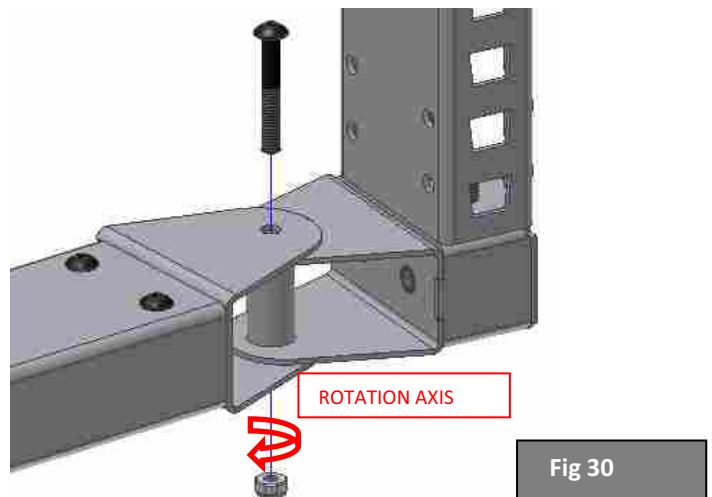

GENERATOR FOR 60° AND 90° ANGLES:

The only difference is that in the part of the generator concerning the **740 single end bar** an **adapter** must be added to the bottom and at the top the **profile** is longer (Fig. 31)

STEP 4b – At the top, mount the **long generator** profile to the **bar** and screw it on with **2 M8x20 DIN 912 Allen screws** (Fig. 32).

At the bottom, mount the **male generator + extension kit** with **2 M6x16 ISO 7380 Allen screws**. Join the kit to the **bar** from below with **2 M8x20 DIN 912 Allen screws + ø8 Grover washers** (Fig. 33)

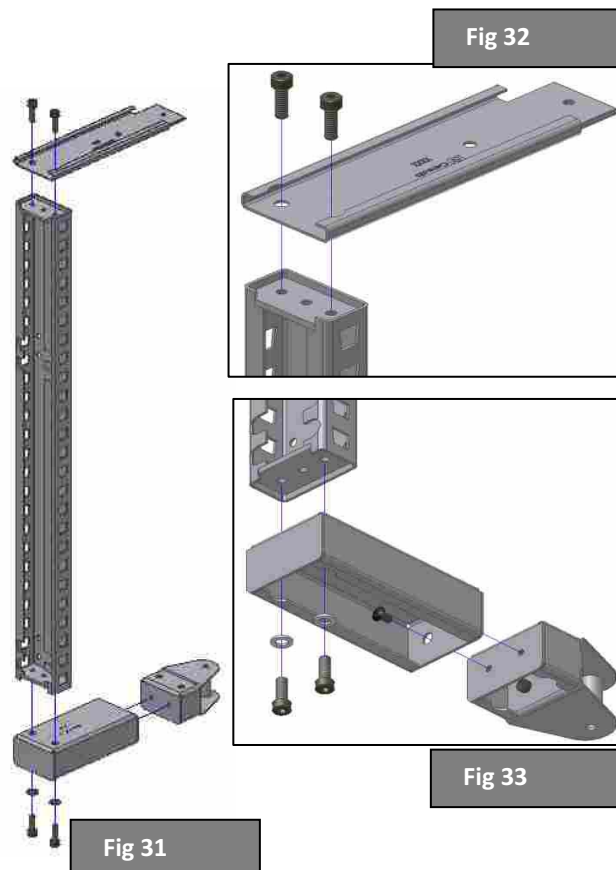

EJEMPLOS DE MONTAJE:

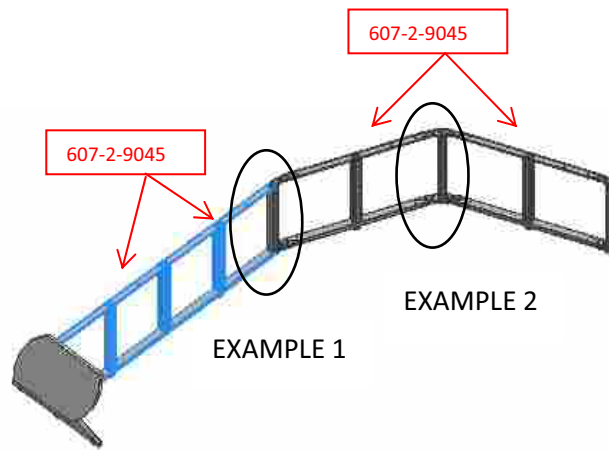

1.- STRAIGHT FRAME + FRAME JOINT: It is just a case of replacing the assembly on the **740 single end bar** for the **740 double middle bar** (the picture does not show the frame joint foot)

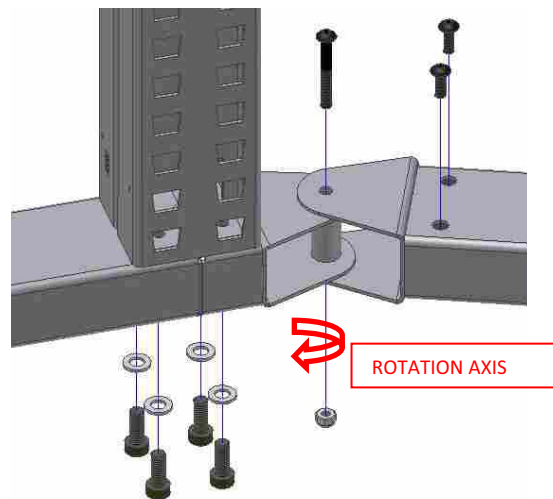
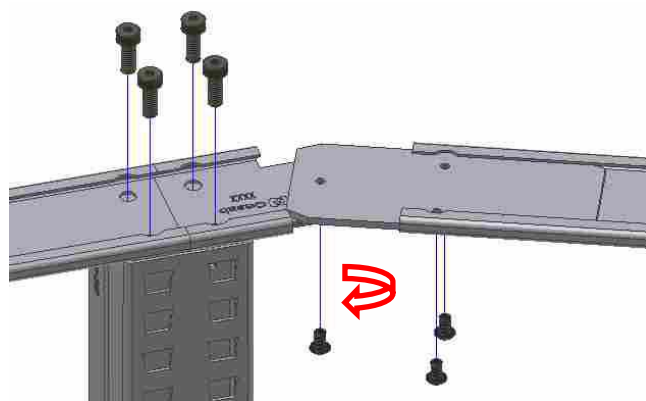

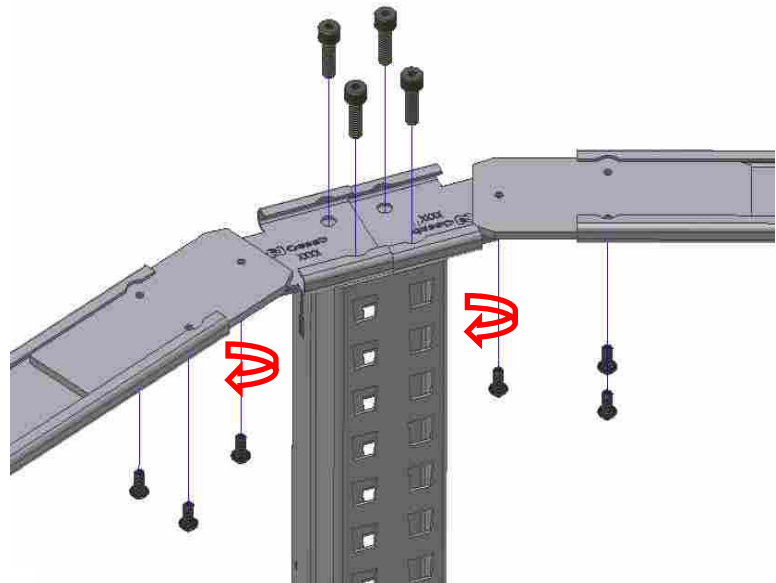

2.- 2 ANGLE FRAMES + FRAME JOINT:
It is just a case of replacing the assembly on the **740 single end bar** for the **740 double middle bar** on both **frames** (the picture does not show the frame joint foot)

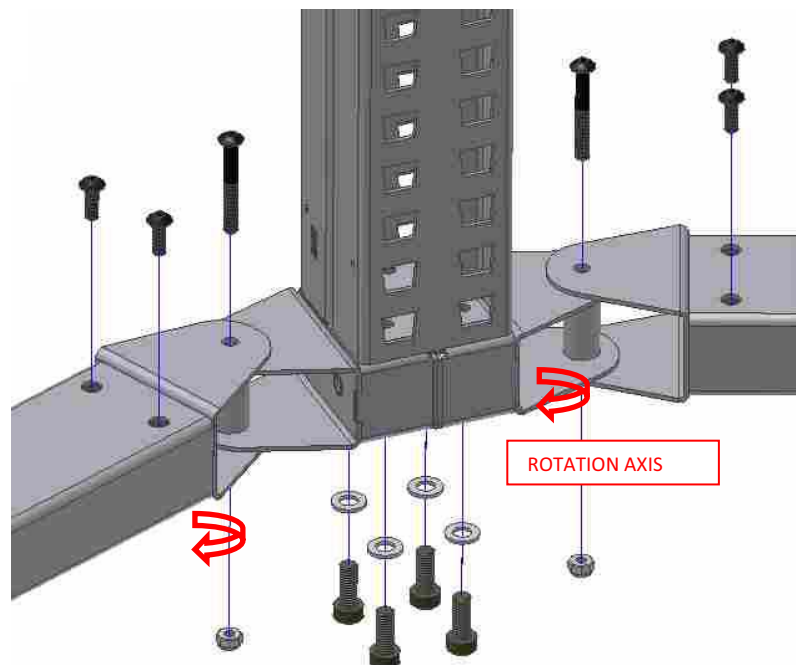

Base Side + Frame Assembly Instructions

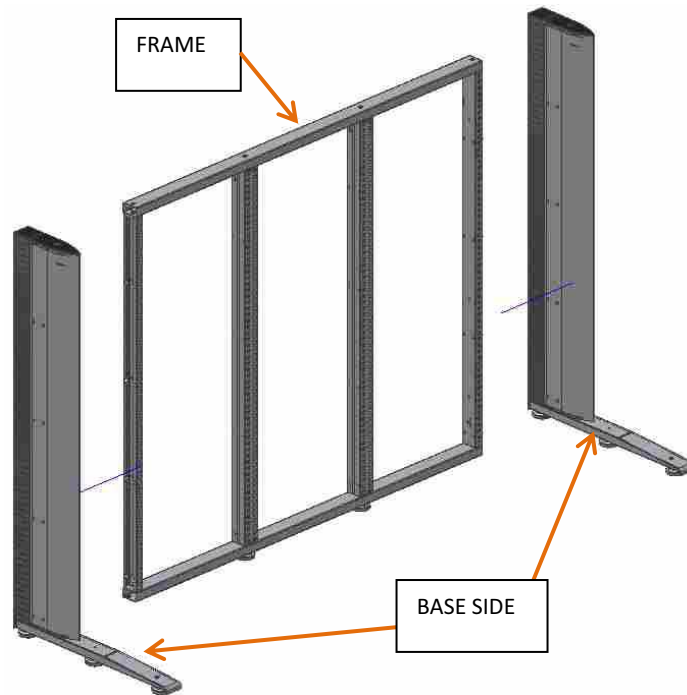

Fig 1

Assembly process

Graphic assembly process



To mount a **frame** on the first **side**, two people are required.

STEP 1 – Before positioning a **side** on the **frame**, remove all the **trim screws** from the side on which you are going to mount the **frame** (Fig. 2). If the **side** is a middle one, remove all the **trim screws**.

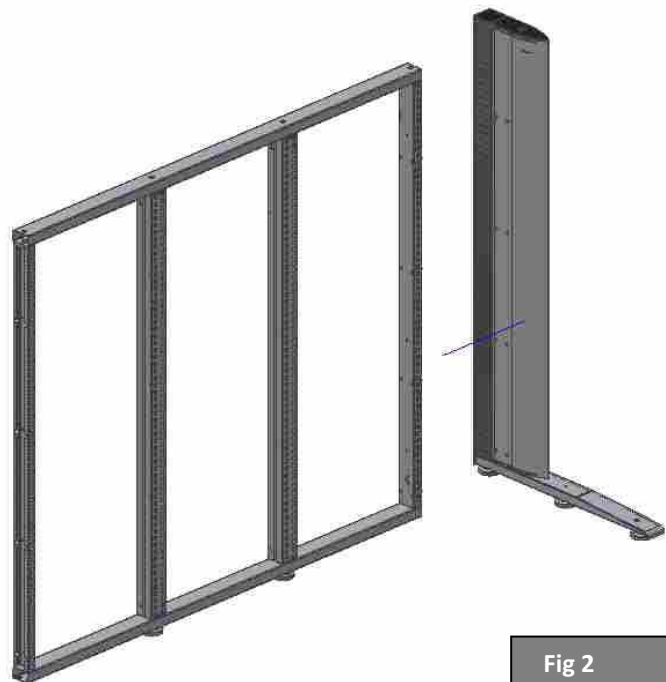

Fig 2

STEP 2 – Screw the **frame** tightly to the **side** with **M6x45/55 ISO7380 Allen screws** (Fig. 3 and 4)

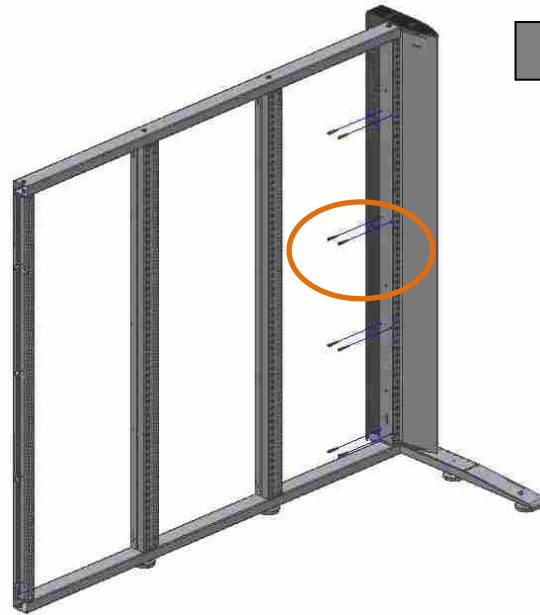

Fig 3



Before tightening all the screws, it is advisable to pre-assemble one top screw and one bottom screw.

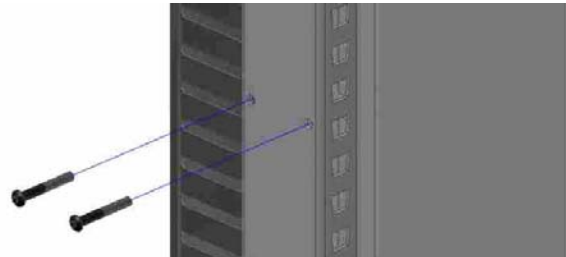

Fig 4

STEP 3 – Position the other **side** and screw it in place as explained in the two previous steps (Fig. 5)



Fig 5

STEP 4 – Level the whole structure using the **levellers** of the **frame** and **sides** (Fig. 6)

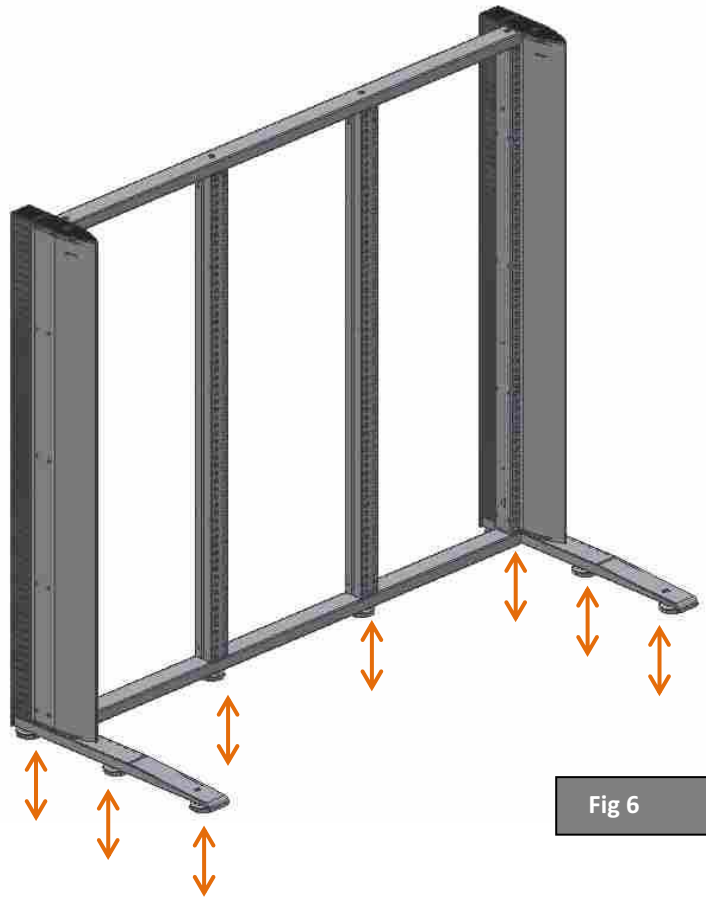

Fig 6

Connecting Post Assembly Instructions

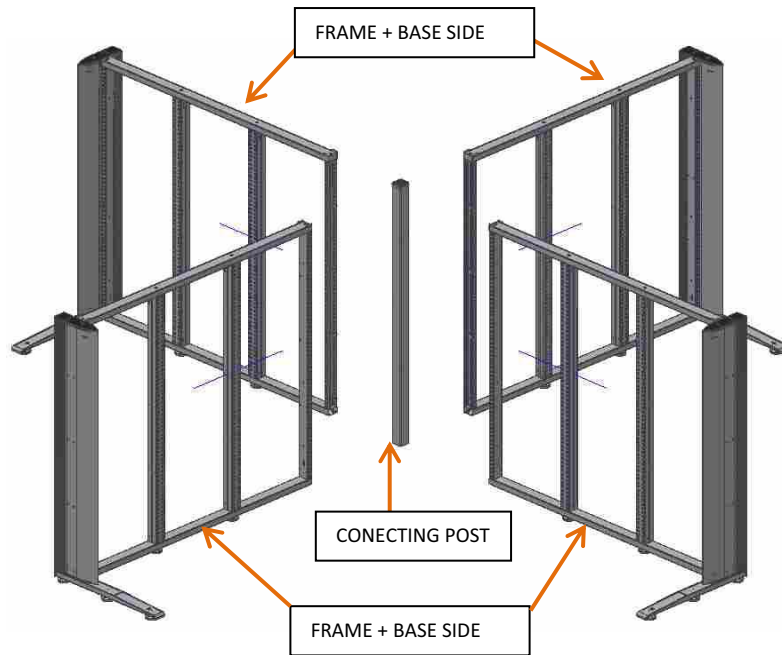

Fig 1

Assembly process | Graphic assembly process



The minimum number of **frames + base sides** that can be mounted to the **connecting post** is 3 (for T-shaped arrangements), and the maximum 4 (for cross-shaped arrangements).



Fig 2

STEP 1 – First mount a line structure (Fig. 2)

STEP 2 – Screw the structures to the **connecting post**. Just one **M6x45 ISO7380 Allen screw** per row and in diagonal form (Fig. 3)

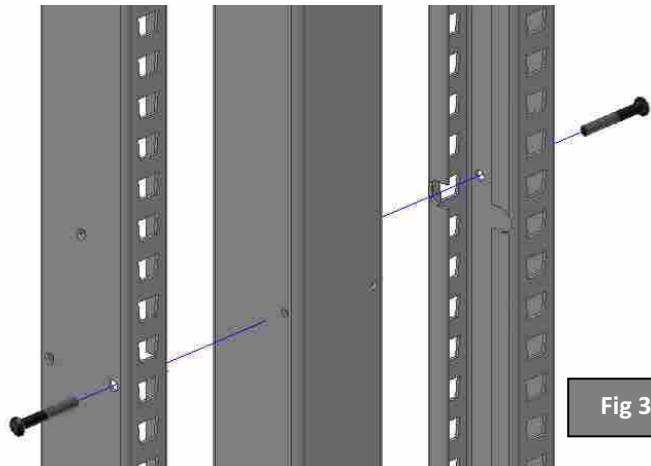

Fig 3

STEP 3 – Mount the other row of structures and screw them in place (Fig. 4)



Fig 4

Frame Joint Assembly Instructions

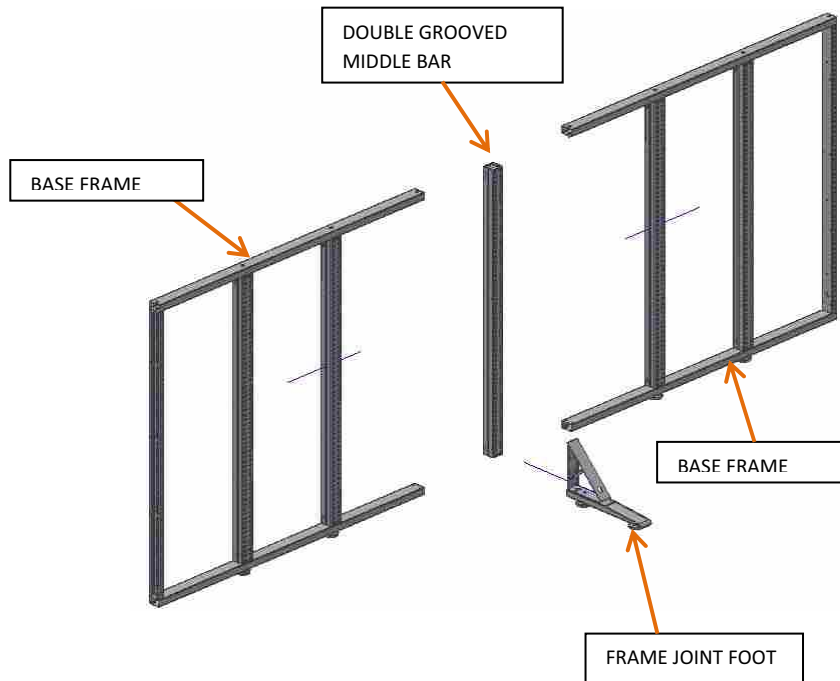

Fig 1

Assembly process | Graphic assembly process



The **frame** must be assembled horizontally, i.e. lying on the floor. The **base frame** assembly is explained in chapter 3 of the assembly guide.

STEP 1 – Position all the components of the **frames** on the floor. At the point where the two **frames** meet, place a double bar to act as a joint (Fig. 2)

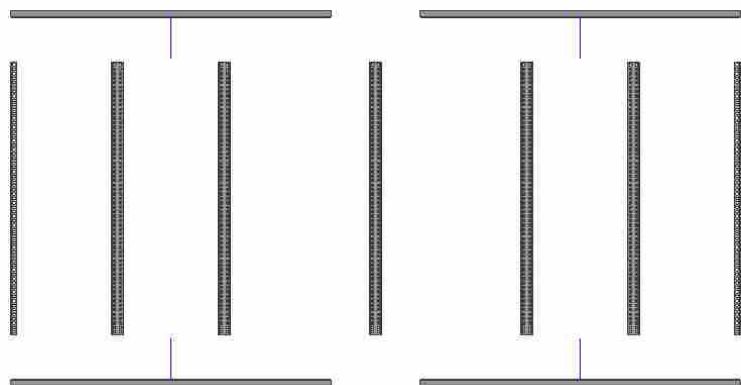

Fig 2

STEP 2 – Screw the **bottom** and **top bars** to the grooved bars.
On the **double joining bar**, 4 screws are needed at the bottom (Fig.3) and **2 M8x20 DIN 912 Allen screws** at the top (Fig. 4).

Fig 3

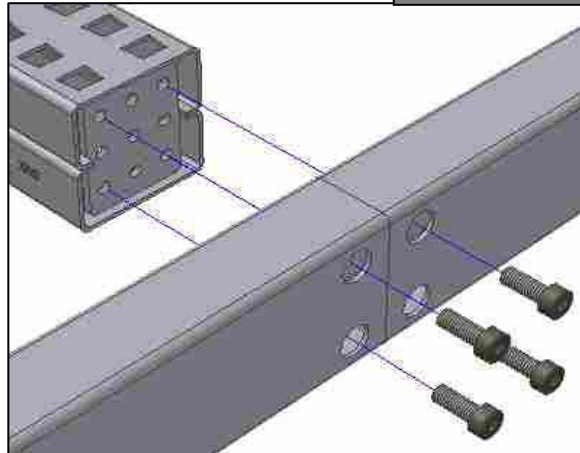
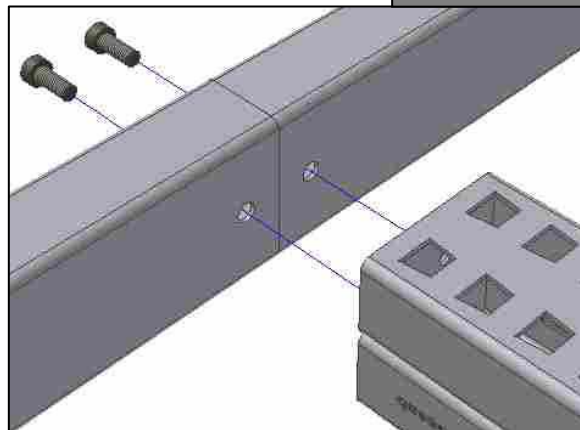

Fig 4



Remember to check the measurements between **frame sections** (see **base frame assembly**, chapter 3)

Fig 5

STEP 3 – Insert all the **frame** plugs in the **top bars**. On the **double joining bar**, 2 are required (Fig. 5)

Mount all the **levellers** of the **frames**.

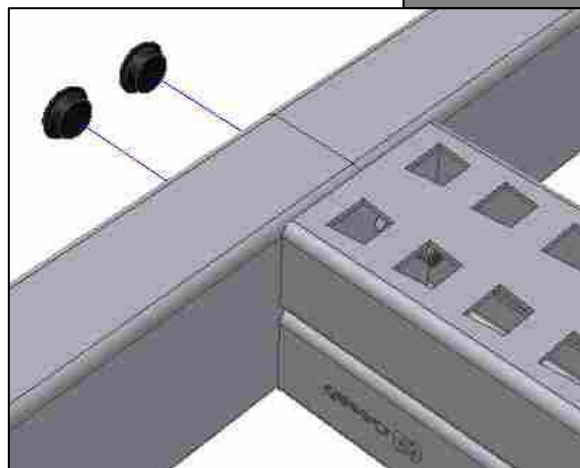

STEP 4 – Mount the **frame joint foot**. Join the **top bracket** to the **foot** with **2 M6x16 ISO7380 Allen screws** (Fig. 6). The two parts must be flush at the back.

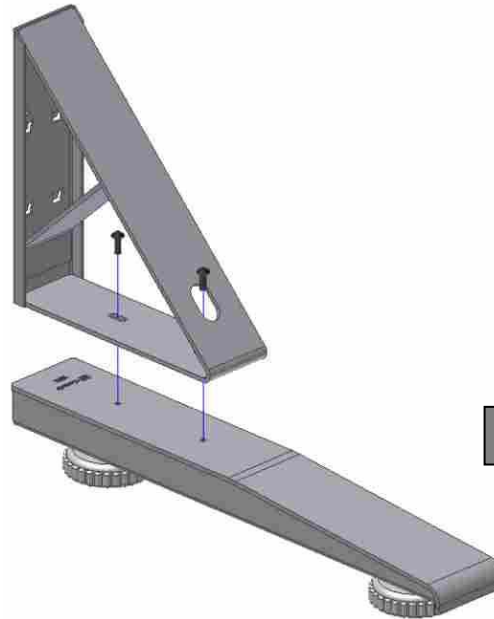

Fig 6

STEP 5 – Position the **frame joint foot** on the already mounted structure (**frames + sides**) in a vertical position, i.e. standing (Fig.7).

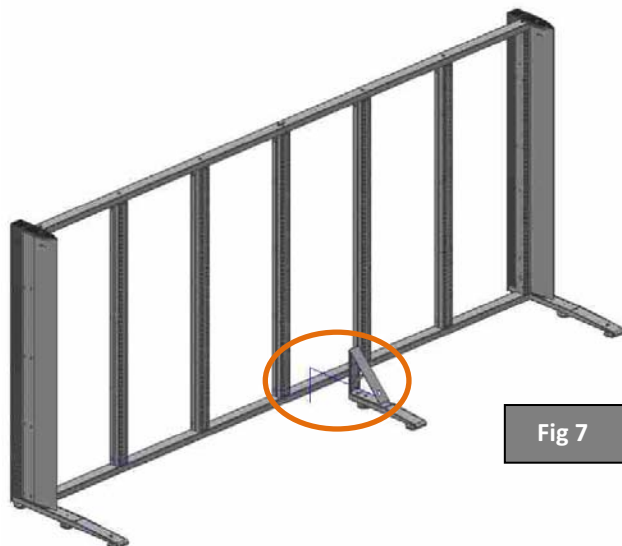

Fig 7

Insert the hooks of the **foot** in the trapezoids of the **bar**. The **foot** has to be level with the other **feet**, i.e. it must touch the floor (Fig.8).

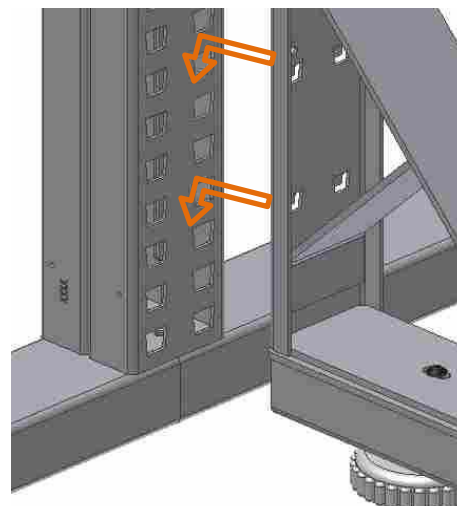

Fig 8

STEP 6 – Join the **joint foot** to the **frame** with **2 M6x10 ISO7380 Allen screws** (Fig. 9)

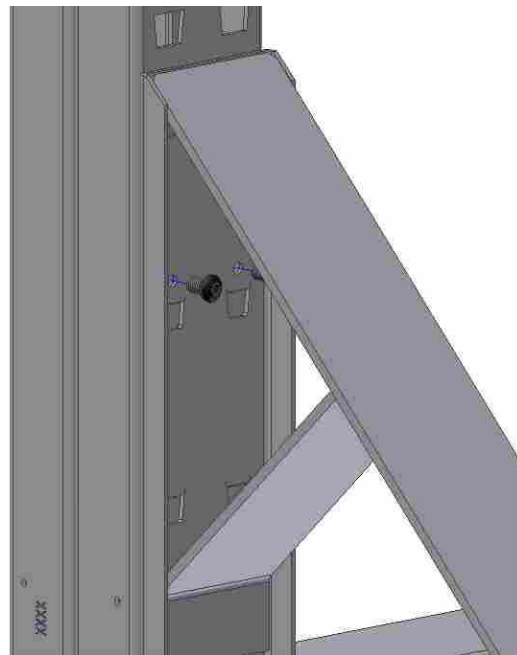

Fig 9

STEP 7 – Adjust the **structure** to the floor using all the **levellers** (Fig.10)

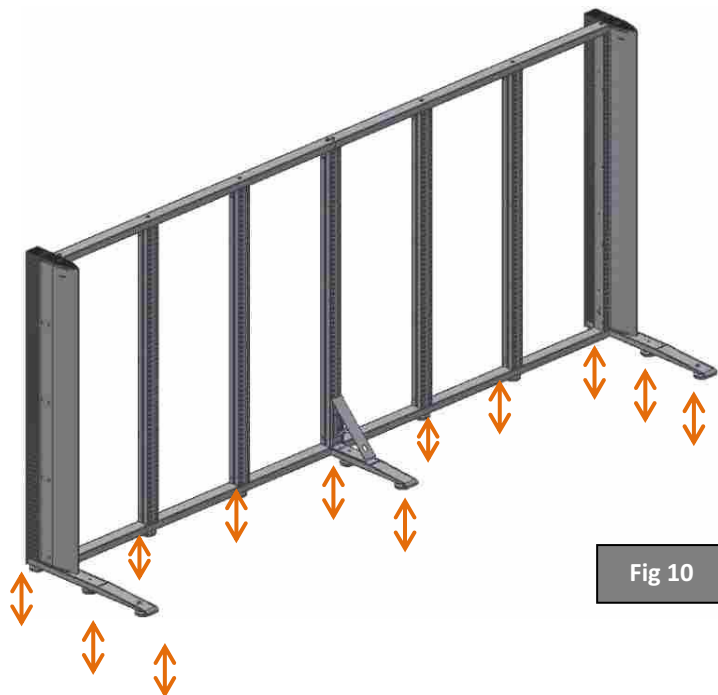

Fig 10

Stabilizer Assembly Instructions

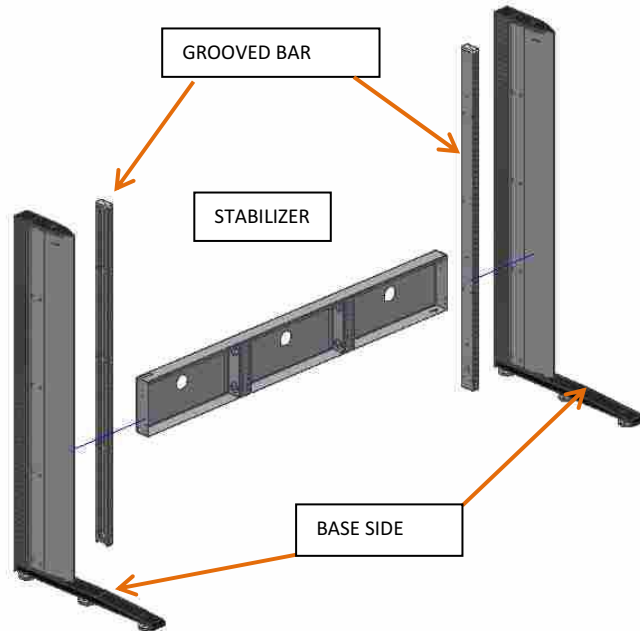

Fig 1

Assembly process | Graphic assembly process



To mount a **stabilizer** to the first **side**, two people are required.

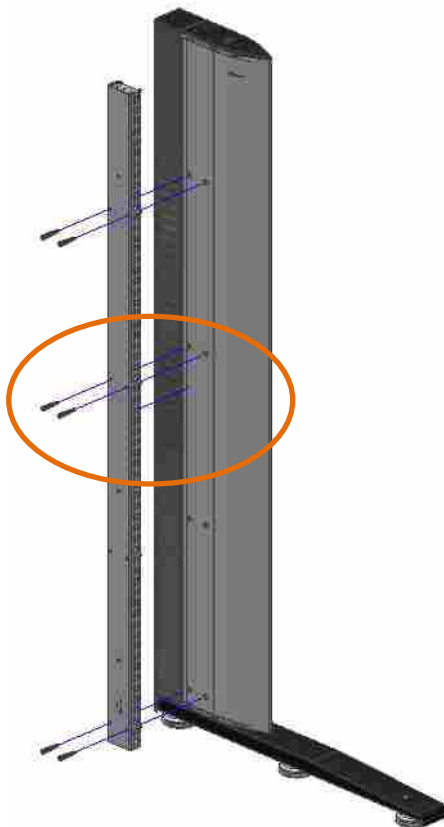
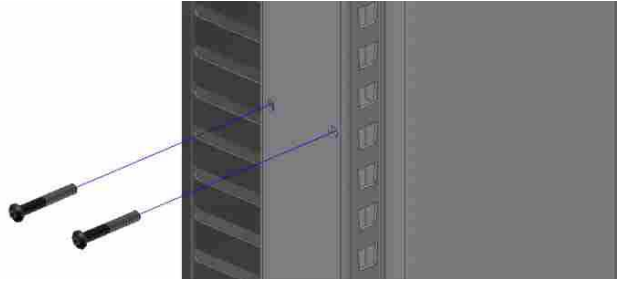

Fig 2

STEP 1 – Position the **grooved bar** on the **base side** after first removing all the **trim screws** from the side you are going to mount on (Fig. 2).
If the **side** is a middle one, remove all the **trim screws**.

Fig 3

STEP 2 – Screw the **bar** tightly to the **side** with **M6x10 ISO7380 Allen screws** (Fig. 3, except for the second row of screws starting from the bottom (Fig. 4).



Before tightening all the screws it is advisable to pre-assemble one top screw and one bottom screw.

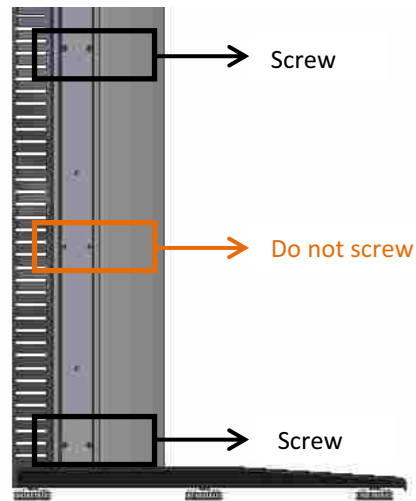

Fig 4

STEP 3 – Position the **stabilizer** and screw it to the **side** (Fig. 5).

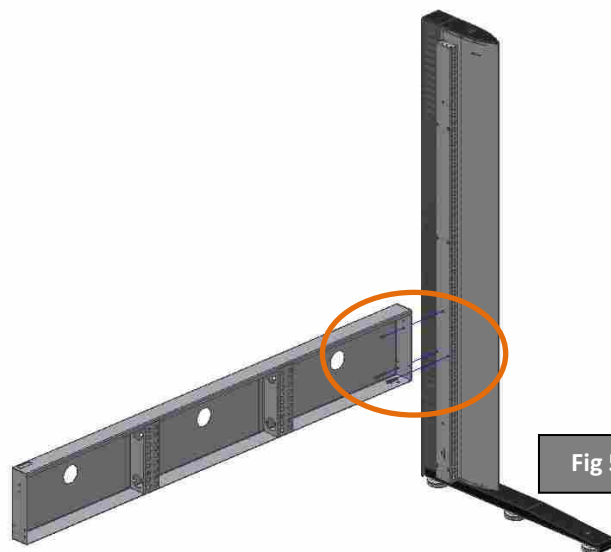
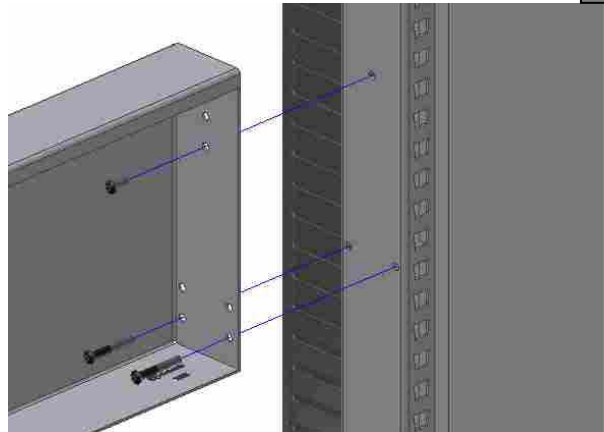

Fig 5

Fig 6

To screw the **stabilizer** to the **side + bar**, use the row which was not used in the previous step (the second starting from the bottom, Fig. 4). You will need two **M6x55** and one **M6x16 ISO7380 Allen screws** per side as shown in Fig. 6.



STEP 4 – Position the other **side + bar** and screw it to the **stabilizer** as explained in the three previous steps (Fig. 7). Check that there are 735mm from the top of the **stabilizer** to the floor.

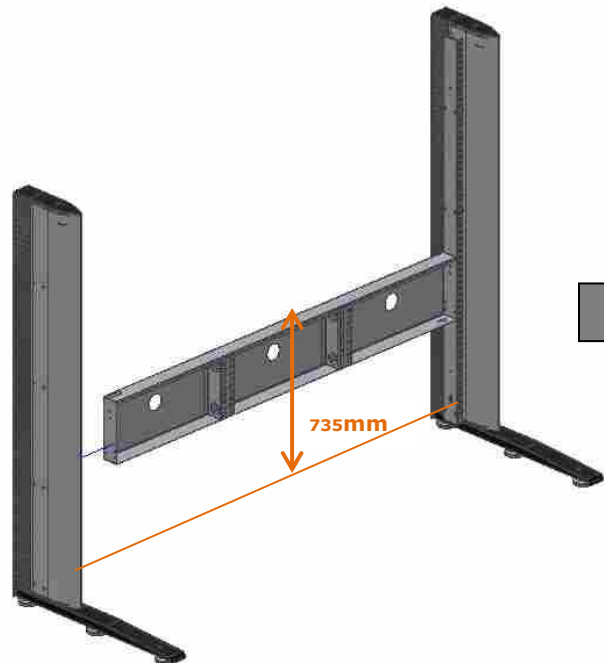

Fig 7

STEP 5 – Place the plastic covers at the tops of the **grooved bars** (Fig. 8).

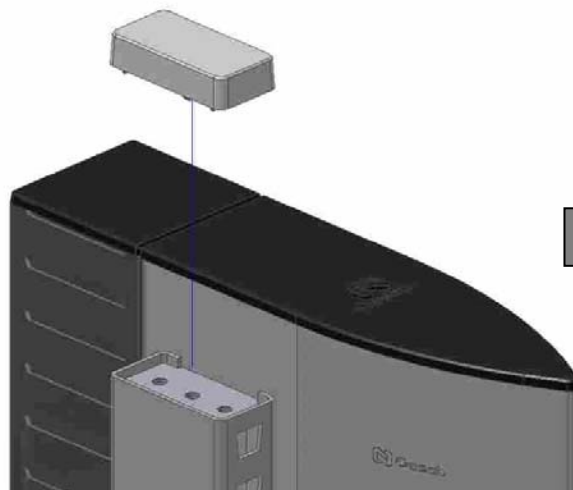

Fig 8

STEP 6 – Level the whole structure using the **levelers** of the **sides** (Fig.9).

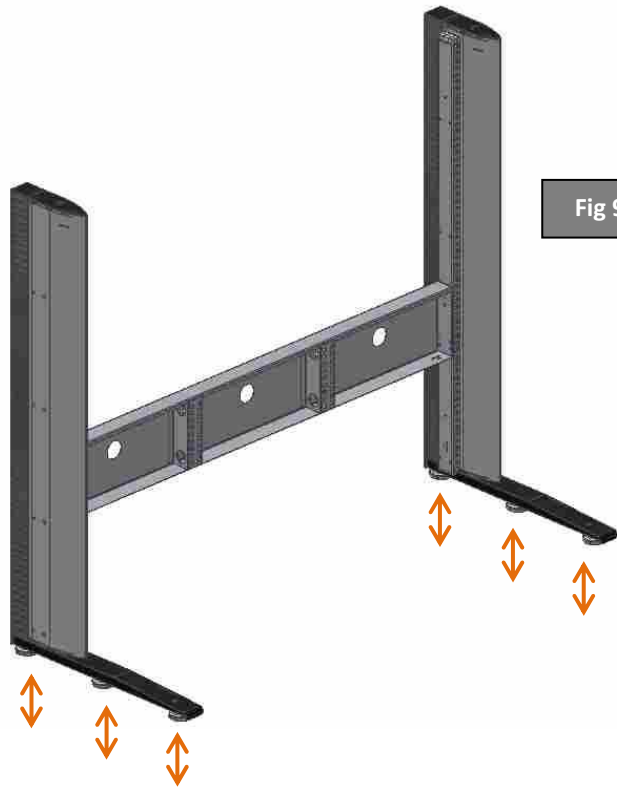

Fig 9

IN HEIGHT 740mm:
The **grooved bar** has to be raised 25mm above the level of the foot in order to be flush at the top of the **side**.
Fig. 10 shows the rows used to assemble the **grooved bar** (the first starting from the bottom) and the **stabilizer** (the second row and upper thread).

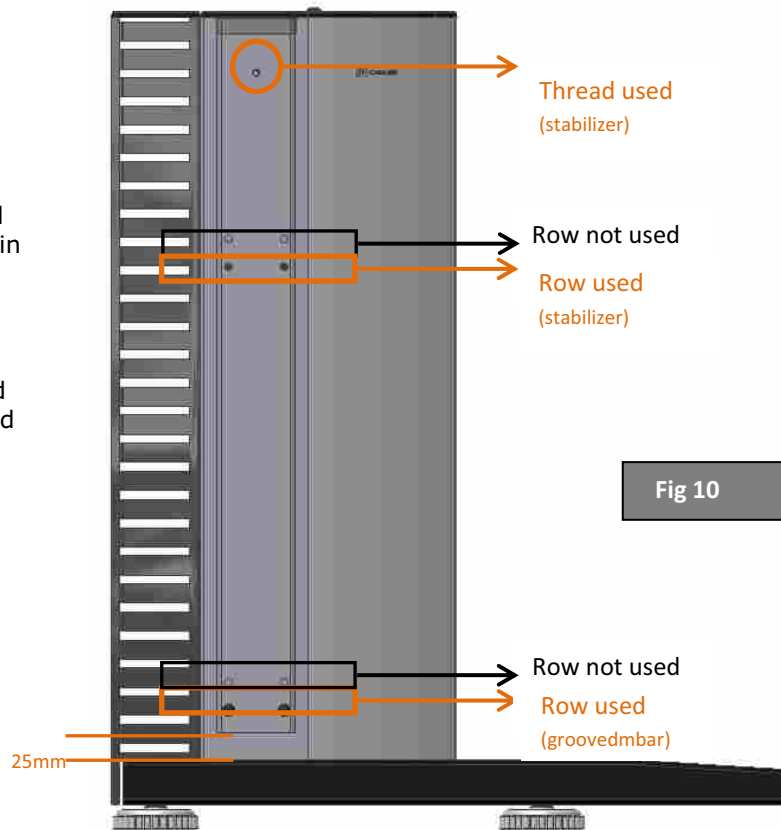

Fig 10

Stabilizer Assembly Instructions

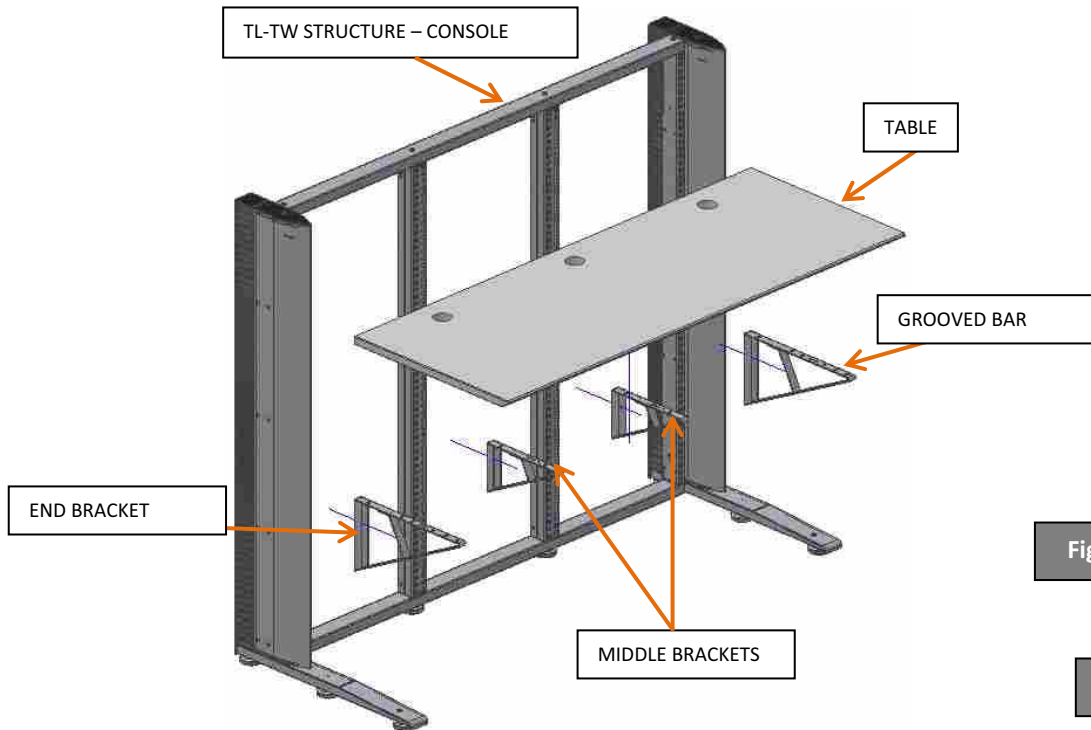

Fig 1

Fig 1

Assembly process

Graphic assembly process



At the sides of the **tables**, the **end brackets** (with 4 hooks) are always used. In the middle of the **1200, 1600** and **1800mm** wide **tables**, the **middle brackets** (with 3 hooks) are used.

See table below:

Table width	N° end brackets	N° middle brackets
600	2	-
800	2	-
1200	2	1
1600	2	1
1800	2	2

STEP 1 - Position the **brackets** on the **structure**. For a correct working height, the top of the **brackets** must be 705mm from the floor (Fig. 2).

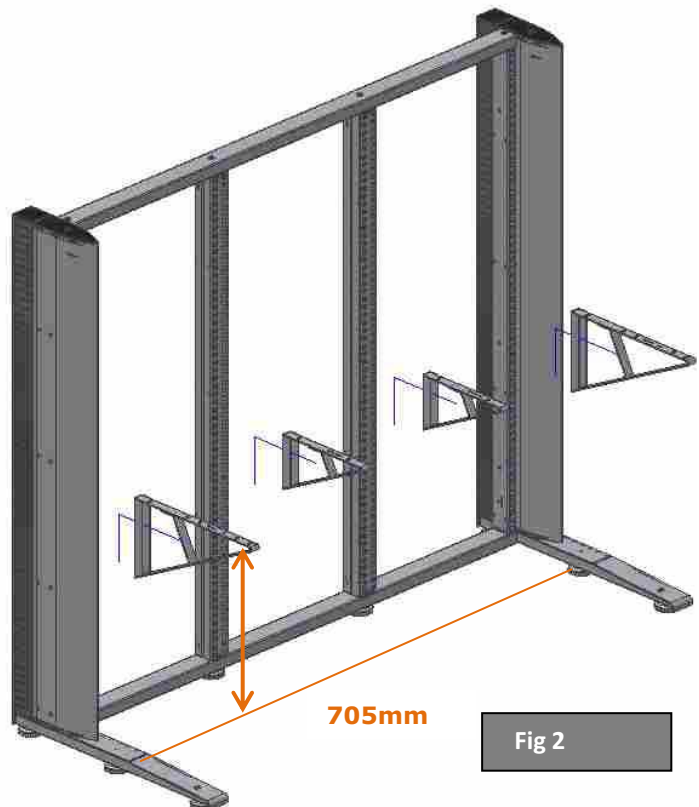
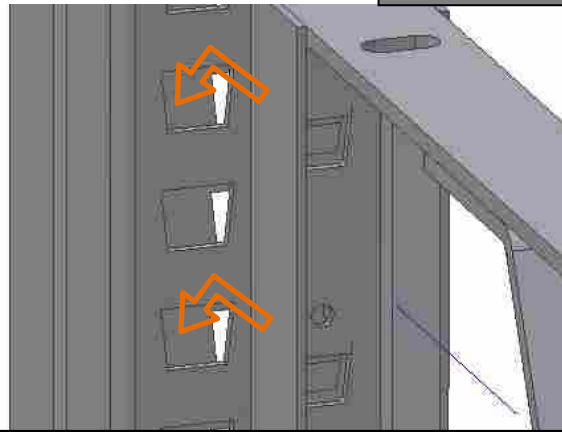

Fig 2

Fig 3

Insert the hooks of the **brackets** into the trapezoids of the **frames** (Fig. 3).
Use a nylon mallet.



CONSOLE TABLES:

STEP 2 – Mount the **safety screws (M6x10 ISO7380)** of the **brackets** to prevent them coming out of the trapezoid (Fig. 4 and 5).

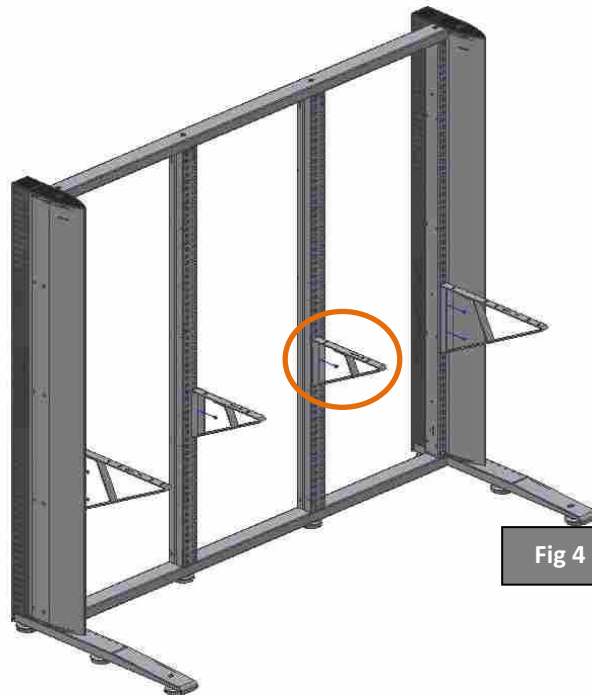

Fig 4

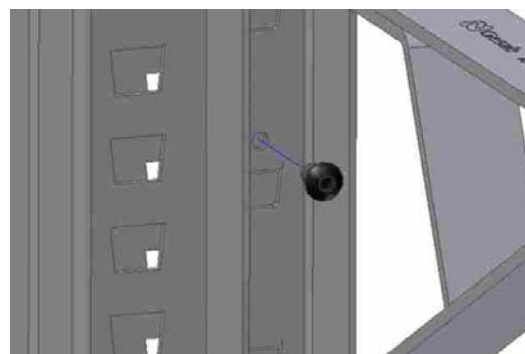

Fig 5

STEP 3 – Place the **table** on the **brackets** and screw them from below with **M6x12 DIN785 Phillips screws** (Fig. 6 and 7).

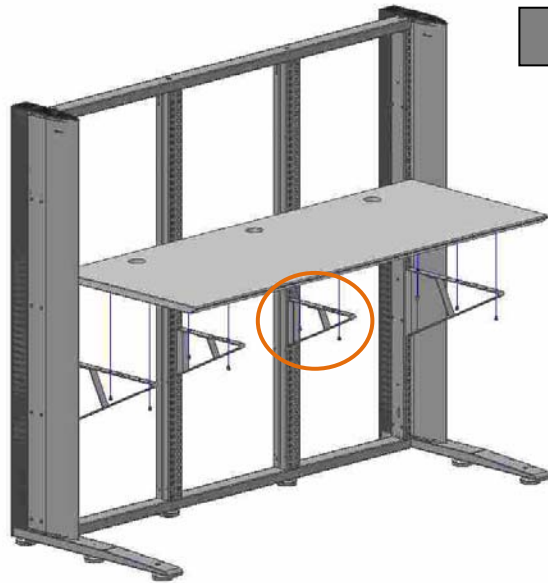

Fig 6

i In the console, leave the screws hand tight only; do not screw them in fully. (see step 4)

i In the **peninsula table**, before placing the table on the **brackets**, the **foot** must be mounted (see step 2.5).

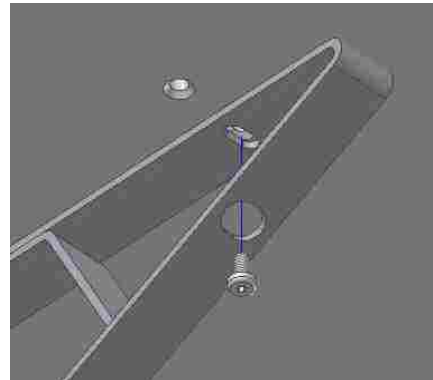

Fig 7

FINISH: Two types of finish can be chosen, as shown in Fig. 8 and 9. The **table** with finish with detachable (only up to half **side**) is used for making continuous lengths of **table** without leaving the middle space of the **side** and in angular arrangements. The **table** with straight finish is used for making independent stretches of **table** and for ending them.



Fig 8



Fig 9

The assembly of the **console tables** is the same; the only difference is that these go above the **frame** (Fig. 10).

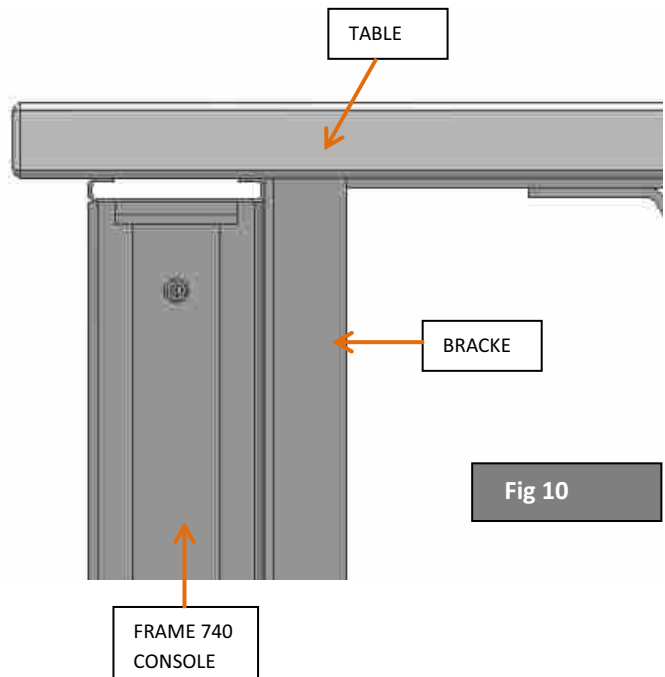

Fig 10

STEP 4 – For middle tables:

Before tightening the table screws, mount the crescent eccentrics (one per side) used to join and adjust the tables (Fig. 11).

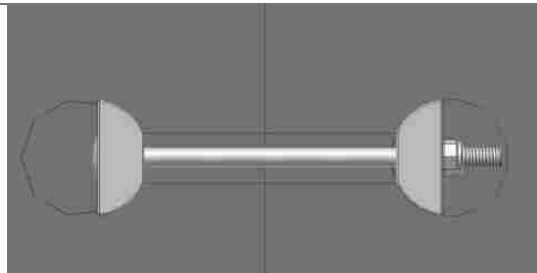

Fig 11

For end tables with agglomerate side:

Insert the M6x70 DIN913 screw in the side (Fig. 12).

Position the table and, before tightening the screws of the brackets, mount the eccentric on one side table-side (Fig. 13) and on the other the middle one, table-table (Fig. 11).

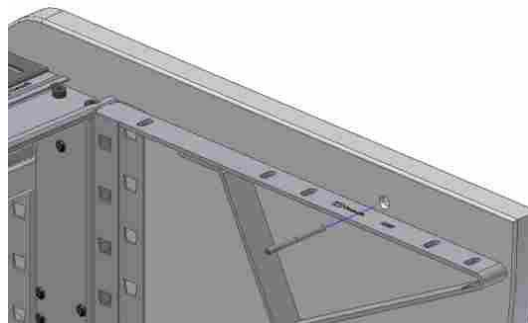

Fig 12

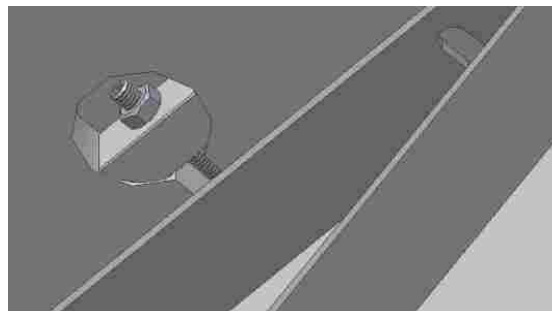

Fig 13

PENINSULA TABLE:

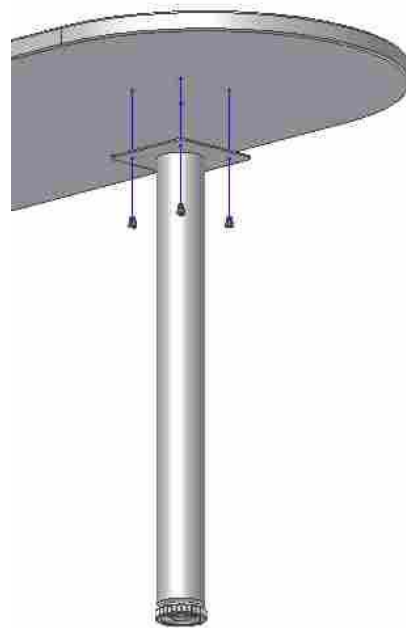

Fig 12

STEP 2.5 – Before placing the table on the brackets, mount the peninsula foot on the end using 4 M6x12 DIN785 Phillips screws (Fig. 12 and 13).

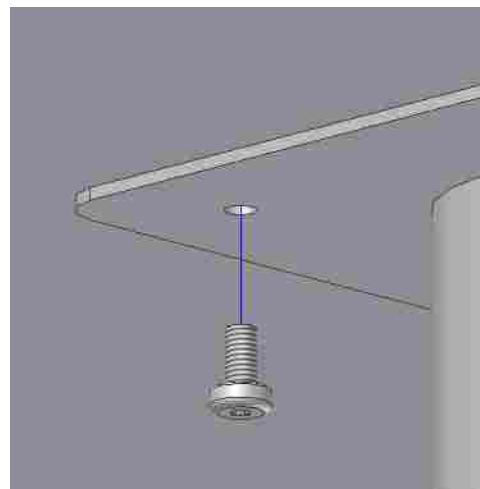

Fig 13

Metal Tray Assembly Instructions

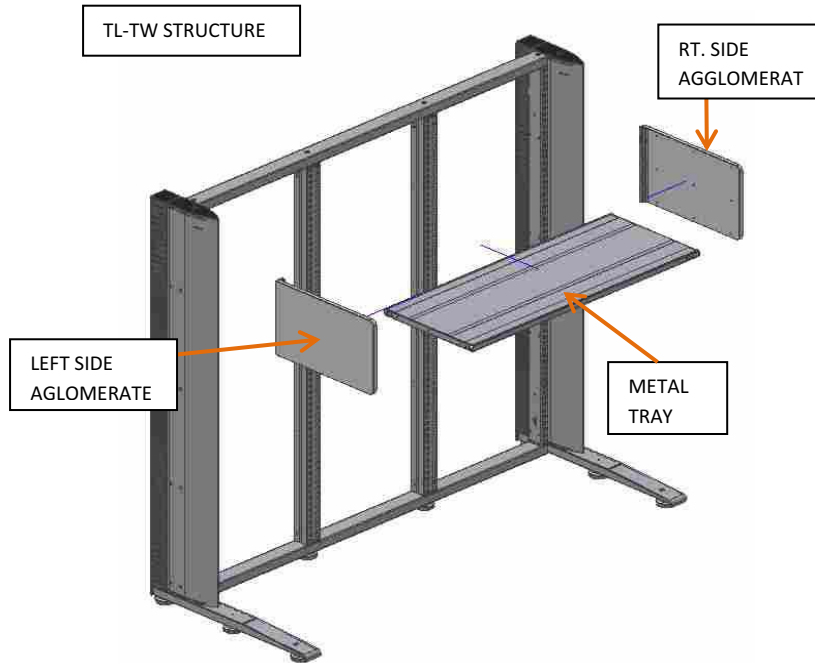

Fig 1

Assembly process

Graphic assembly process



Assembly valid for all depths, widths and heights of side and angular arrangements. These trays can be mounted at any height.

STEP 1 – Insert the hooks of the **sides** in the trapezoids of the **grooved bars**. Both must be at the same height (Fig. 2 and 3).

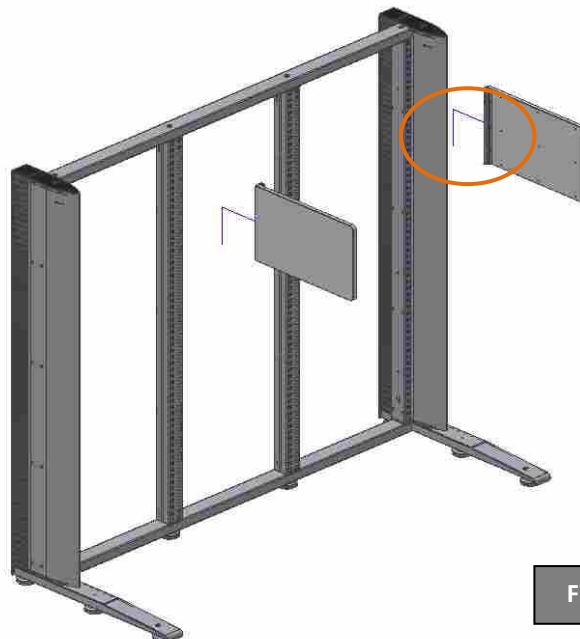

Fig 2



Fig 3

STEP 2 – Insert the 4 **M5x12 DIN785 Phillips screws** of the ends of the **sides** without fully tightening them (Fig. 4 and 5).

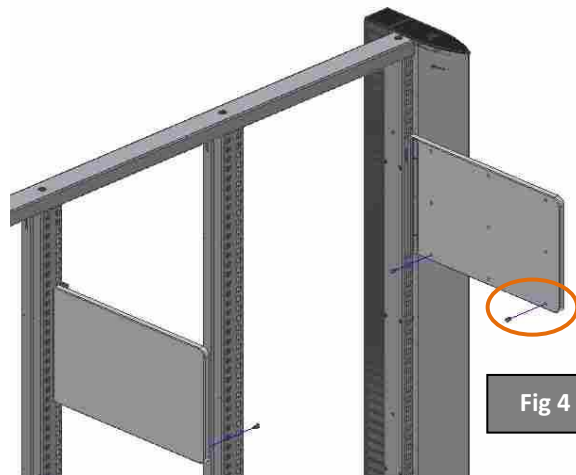

Fig 4



In **tilt trays**, change only the side. See STEP 2b

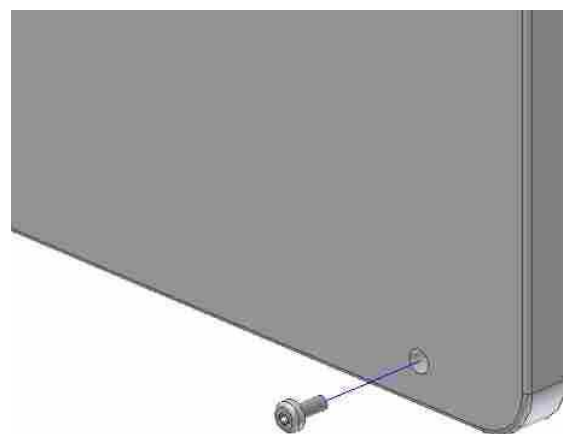

Fig 5

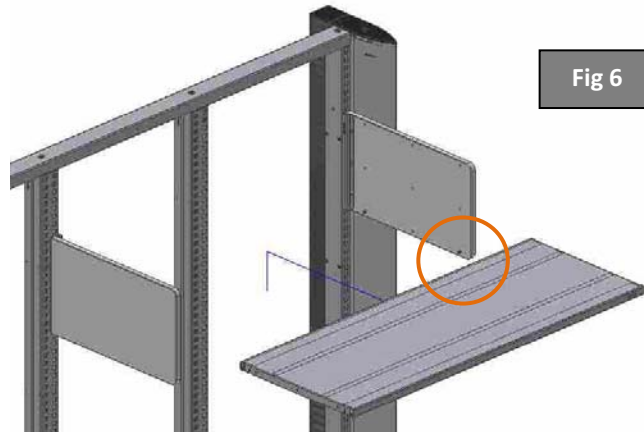

Fig 6

STEP 3 – Position the **tray** in such a way that the previously mounted screws enter the slots in the same (Fig. 6 and 7)

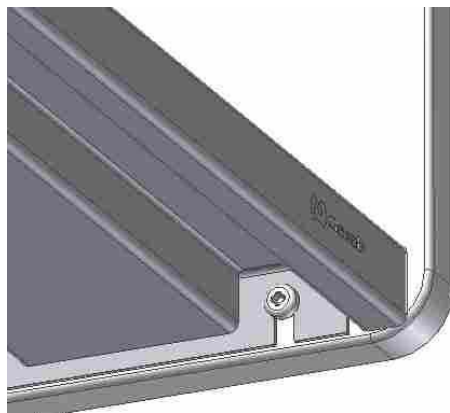

Fig 7

STEP 4 – Tighten all the screws and mount the 2 last middle **M5x12 DIN785 Phillips screws** (Fig. 8).

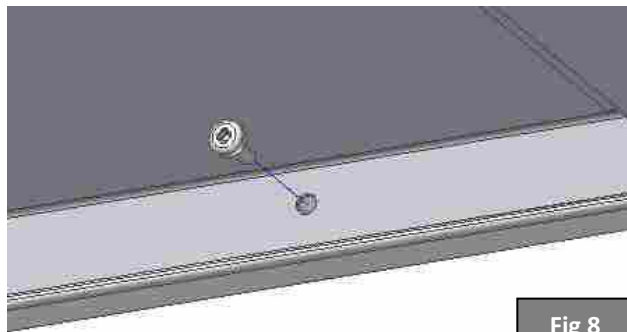

Fig 8

TILT TRAYS:

The only difference with **tilt trays** is that the arrangement of the bushes on the **side** of these is diagonal in order to obtain the desired angle.

STEP 2b – Insert the 4 **M5x12 DIN785 Phillips screws** of the ends of the **sides** diagonally without fully tightening them (Fig. 9).



There are no **tilt trays** in angular arrangements.

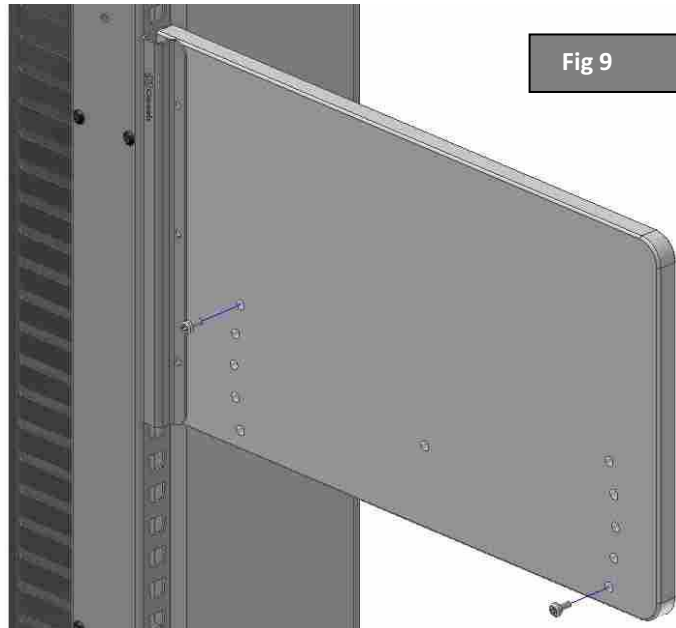

Fig 9

HIDDEN SUPPORT:

This support is used to reinforce the **trays** when these have to support a heavy load.

Support valid for **trays** with lengths of 1200, 1600 and 1800mm, i.e. that have free **double bars** in the middle.

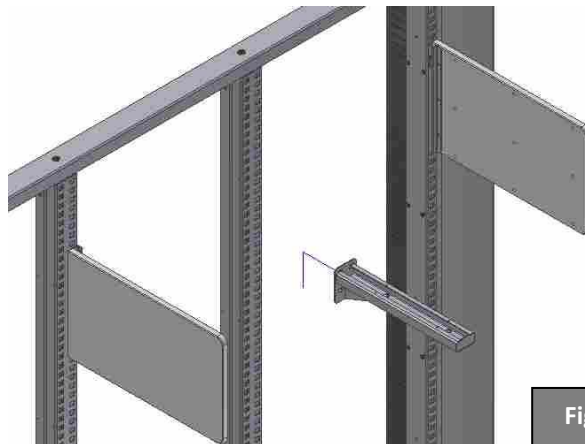

Fig 10

STEP 2.5 – Place the **hidden support**, using the hooks, on the middle **double frame bar** between the **agglomerate sides** of the **metal trays** (Fig. 10). Place it just below the **sides** (Fig. 11).

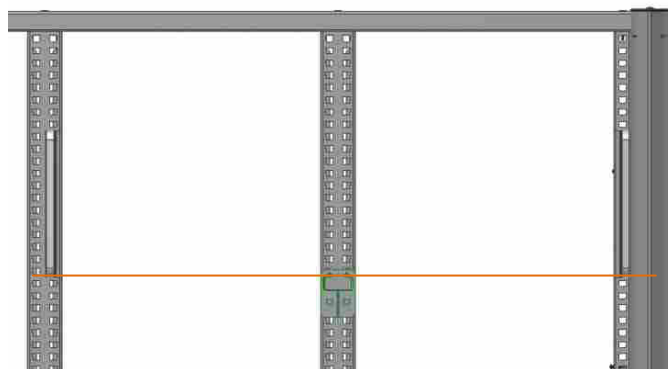
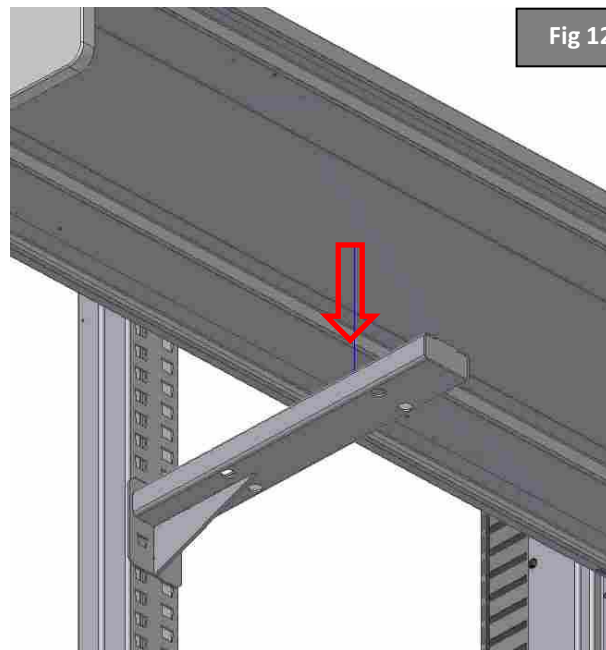
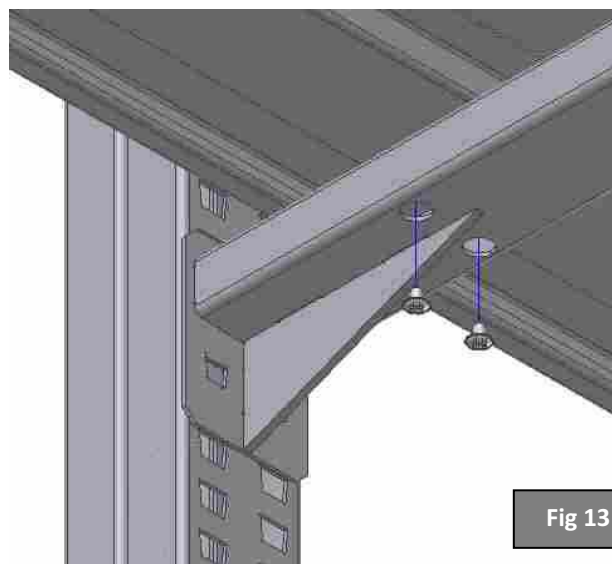

Fig 11

STEP 3.5 – Once in place, the **metal tray** must be perfectly leveled (Fig. 12).



STEP 4.5 – Machine $\varnothing 4\text{mm}$ holes under the **metal tray** (in the bottom profile) using the holes of the support as guides and screw in as many **4.9x13mm threaded screw-locks** (Fig. 13) as possible.



Shelf Assembly Instructions

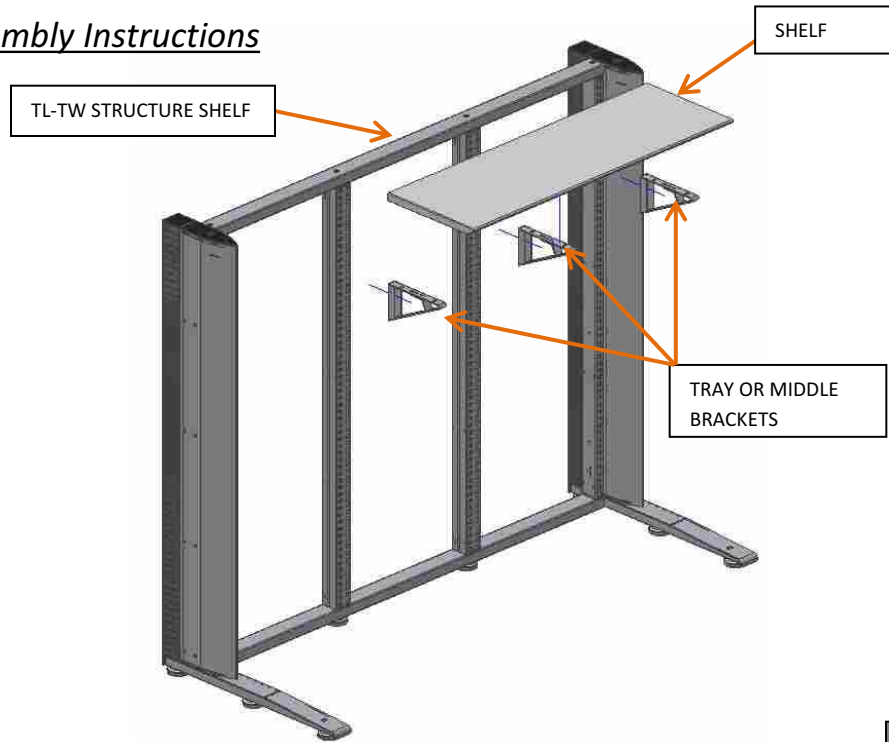

Fig 1

Assembly process | Graphic assembly process

Shelves with a depth of 300 and 400mm use **tray brackets** (height 130mm) and 500mm **shelves** use **middle brackets** (height 170mm).

See table below:

Shelf width	Nº brackets	Tray Bracket	Middle bracket
600	2	300/400	500
800	2	300/400	500
1200	3	300/400	500
1600	3	300/400	500
1800	4	300/400	500

STEP 1 – Position the **brackets** on the **structure**. They must all be at the same height (Fig. 2).

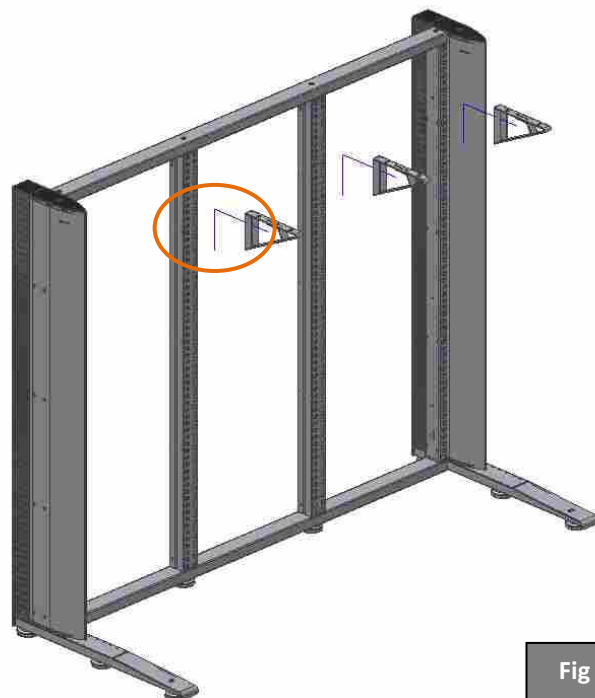
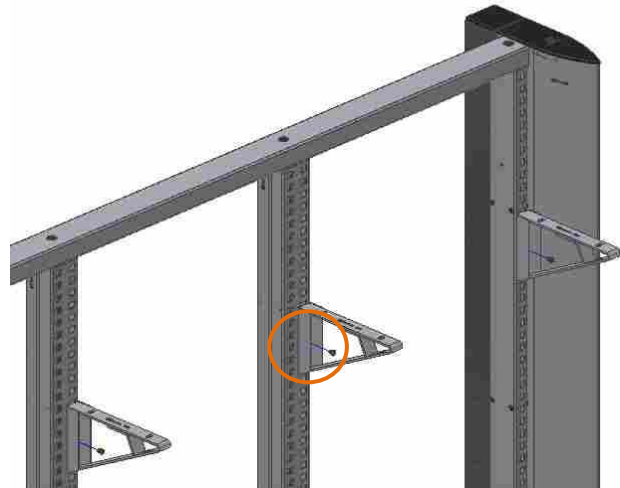
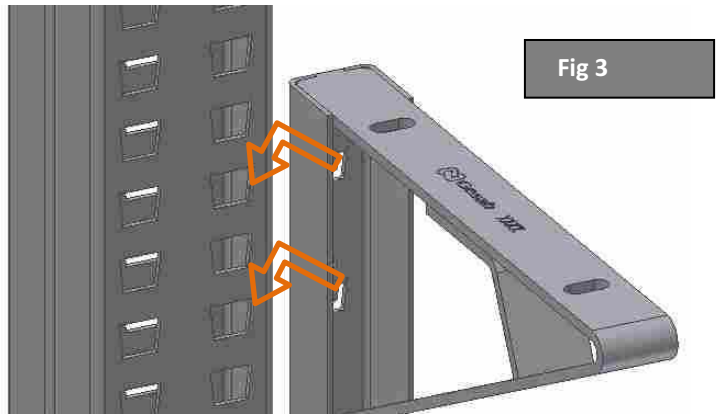

Fig 2

Insert the hooks of the **brackets** in the trapezoids of the **frames** (Fig. 3).
Use a nylon mallet.



STEP 2 – Mount the **safety screws** (**M6x10 ISO7380**) of the **brackets** to prevent them coming out of the trapezoid (Fig. 4 and 5).

Fig 4

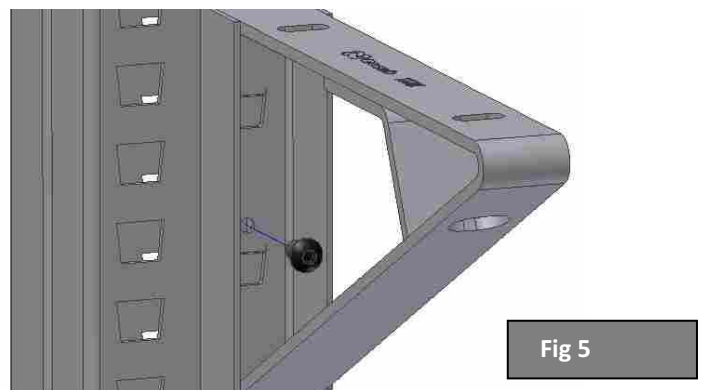
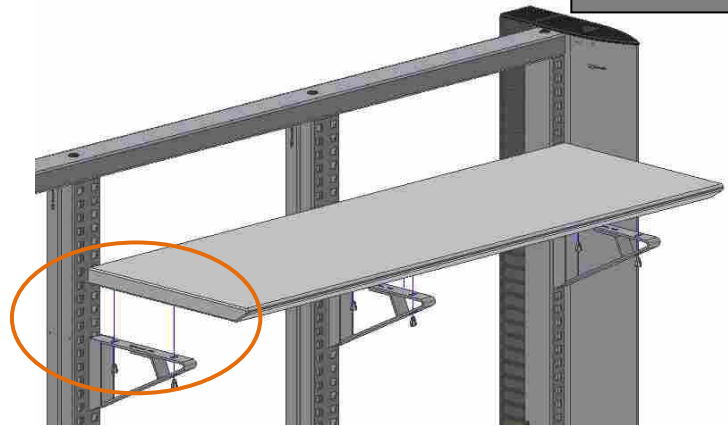

Fig 6



STEP 3 – Place the **shelf** on the **brackets** and screw them in place from below with **M6x12 DIN785 Phillips screws** (Fig. 6, 7 and 8).

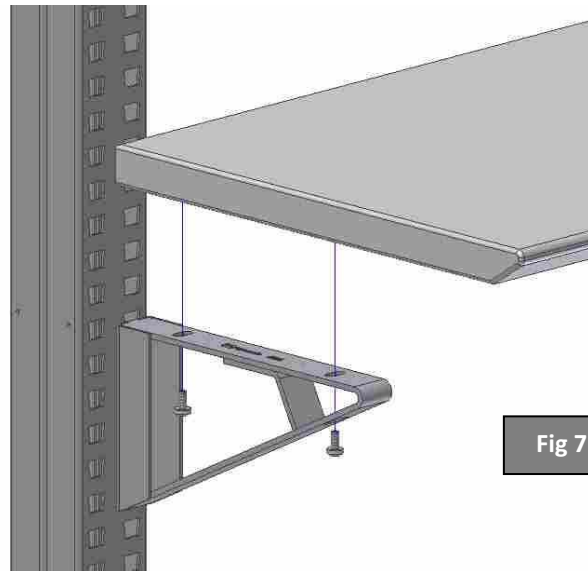

Fig 7

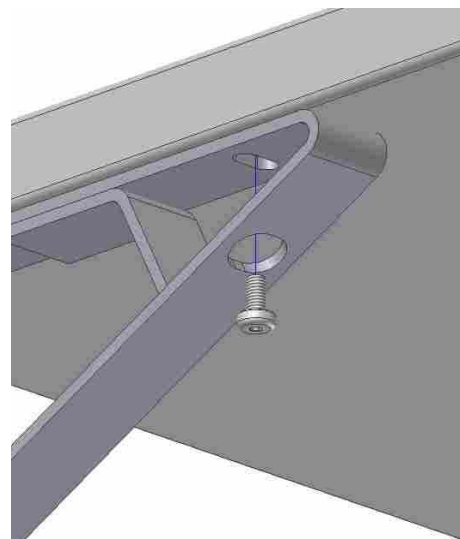

Fig 8

Shelf Assembly Instructions

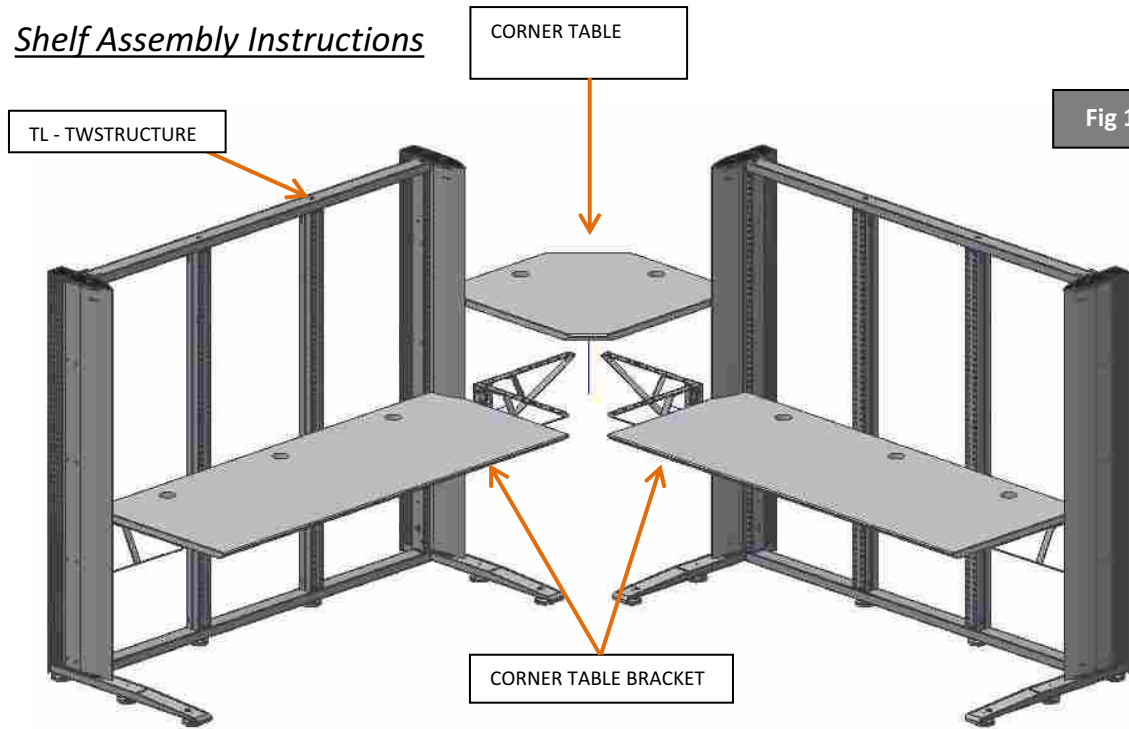

Fig 1

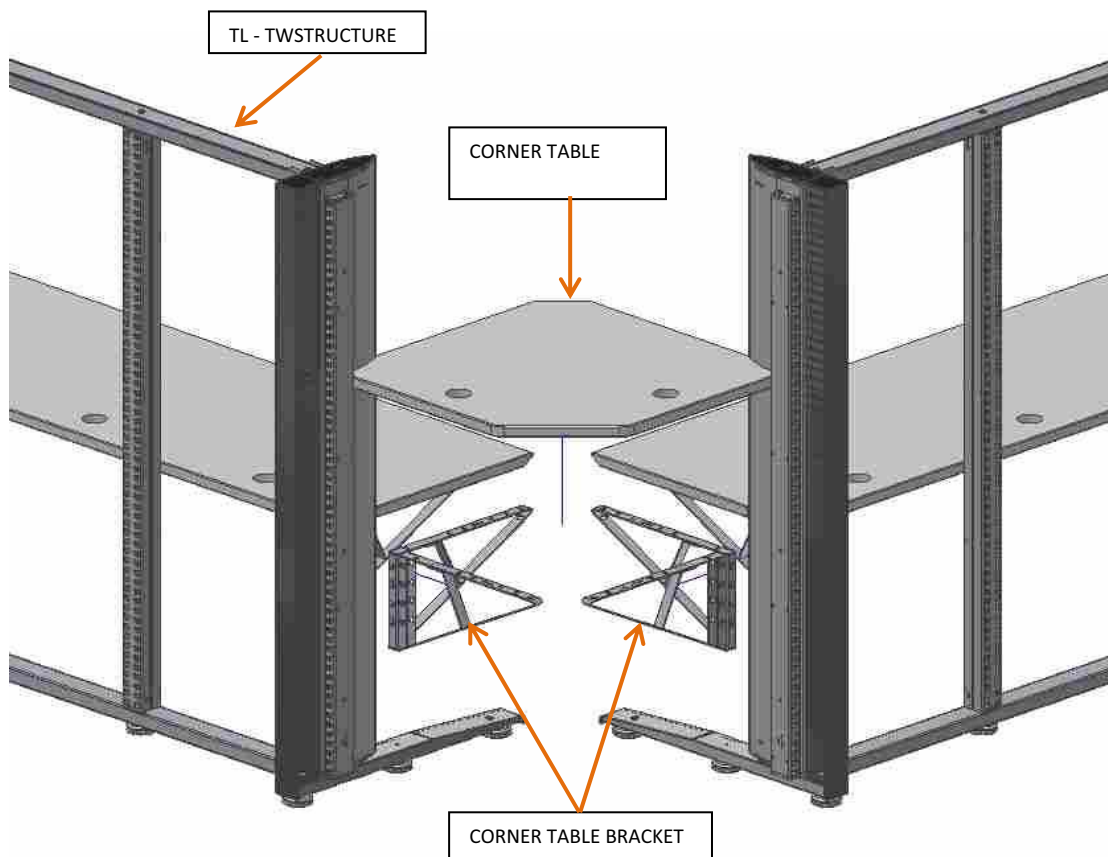

Fig 2



For the assembly of both **corner tables** and **corner shelves**, two **TL-TW structures** are required for the attachment of the **corner brackets**.

STEP 1: Fully assemble the corresponding **TL-TW structures** and position them as shown in Fig. 3, so that the space between structures is similar to the shape and size of the **corner table**.

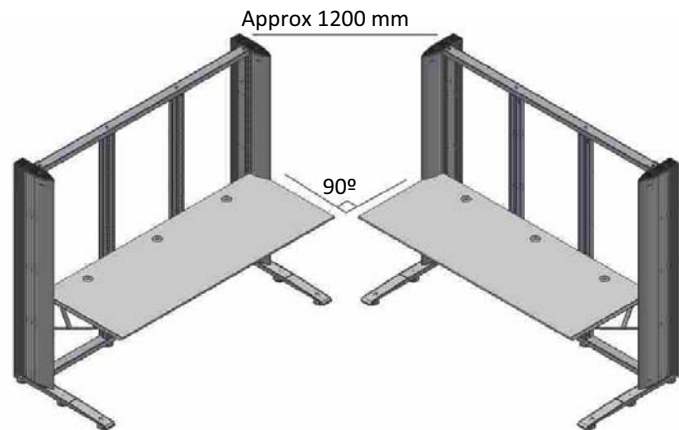

Fig 3

STEP 2:

A) Position the **grooved bars** in the **base sides** where the **corner brackets** will be located (Fig. 4).

B) Screw the **grooved bar** tightly to the **side** using **M6x45/55 ISO7380 Allen screws** (Fig.5).

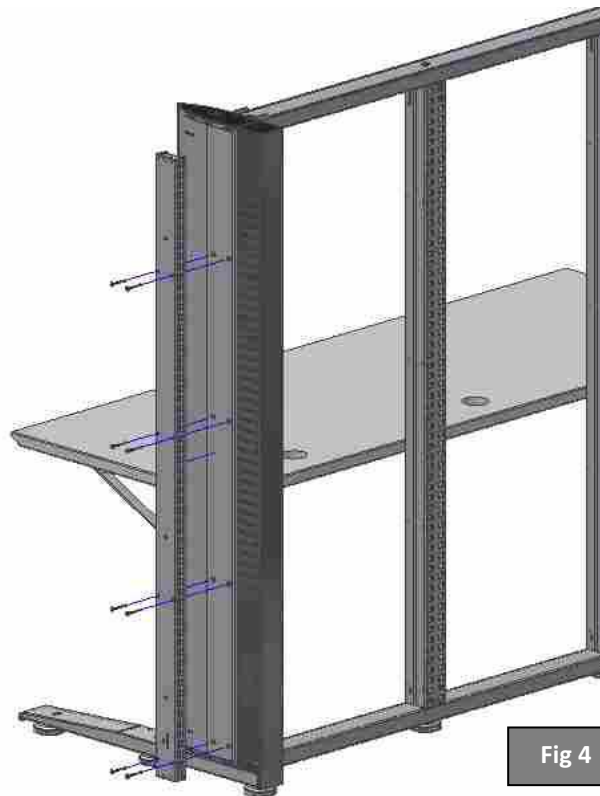

Fig 4



Before tightening all the screws, it is advisable to pre-assemble one top screw and one bottom screw.

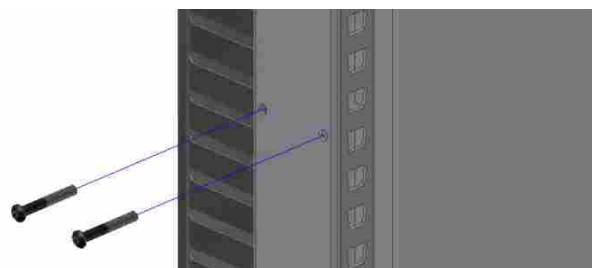

Fig 5

C):Place the plastic covers at the tops of the **grooved bars** (Fig. 6)

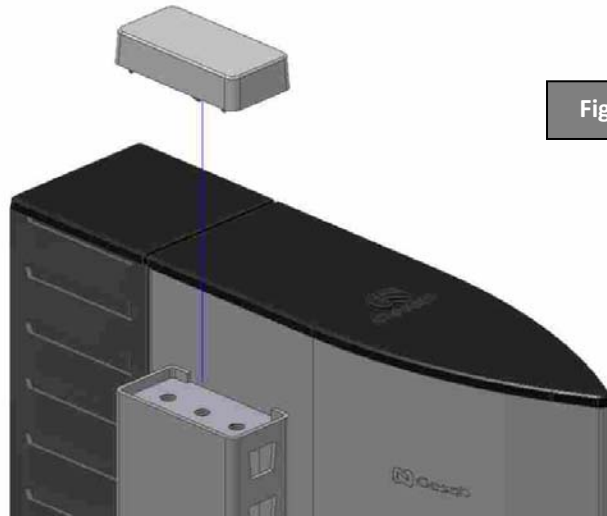

Fig 6

Fig 9

STEP 3- Outside the assembly:
assemble the **corner bracket** formed
by two **end brackets** (with 4 hooks).

A) Insert the hooks of the **brackets** (1) in the trapezoids of the **bracket** (2) (Fig. 7).
Use a nylon mallet.

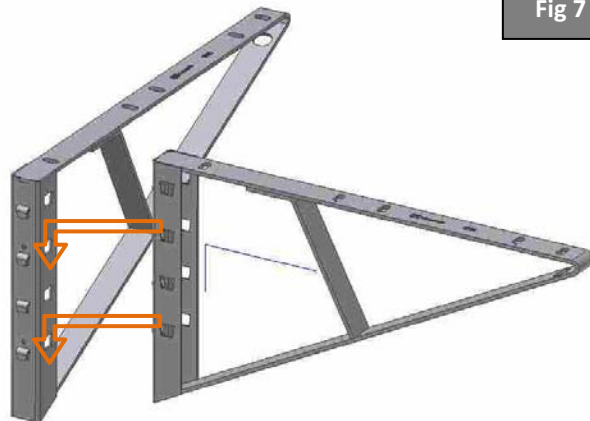

Fig 7

B) Mount the **safety screws (M6x10 ISO7380)** between the **brackets** to prevent them coming out of the trapezoid (Fig. 8).



Fig 8



The tops of the two **brackets** should be on a level for the placement of the **tables or shelves**.

STEP 4: A) Insert the hooks of the **corner bracket** in the trapezoids of the **grooved bar** (Fig. 8).
Use a nylon mallet.



They have to be on a level with the adjacent brackets in order for the **tables** to run continuously on from each other.

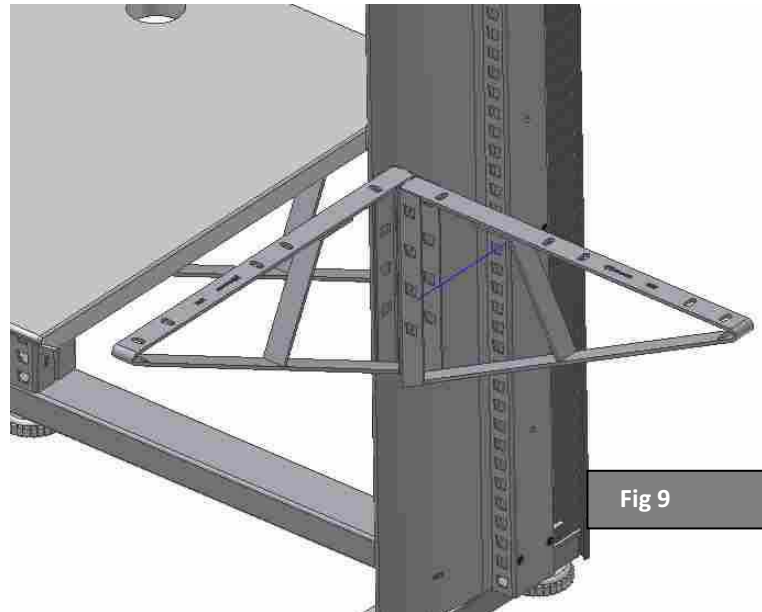

Fig 9

B) Mount the **safety screws (M6x10 ISO7380)** of the **brackets** to prevent them coming out of the trapezoid (Fig. 10).

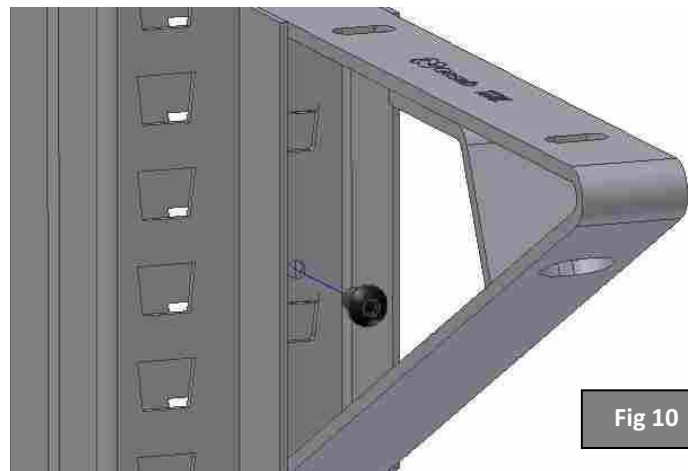
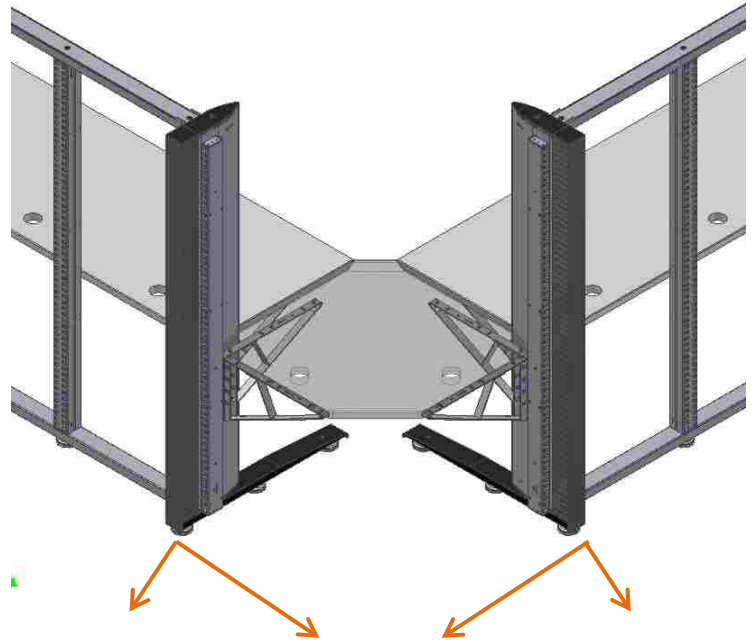

Fig 10

Fig 11

STEP 5: Place the **corner table** on the **corner brackets** to reposition the **structure** correctly so that the **table** coincides with the adjacent ones.



STEP 6: Join the **corner table** to the **corner brackets** from below using **M6x12 DIN785 Phillips screws** (Fig. 12).

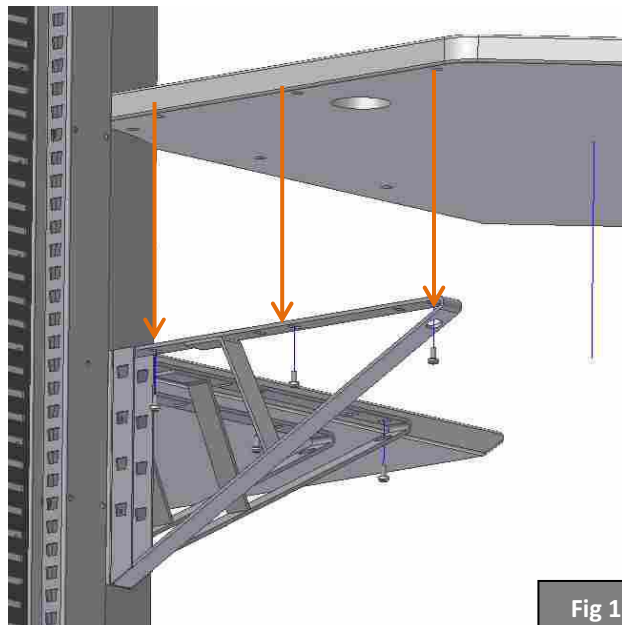

Fig 11

i Shelves with depths of **300 and 400mm** use **double tray brackets** (with 2 hooks) and **500mm shelves** use **double middle brackets** (with 3 hooks).

See table below:

	Shelf width	N° middle brackets
300	X	
400	X	
800		X

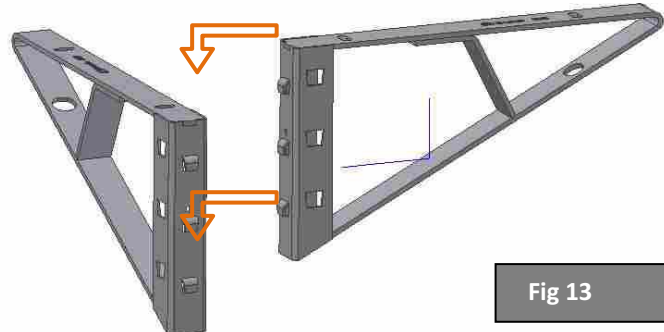

Fig 13

STEP 1- Outside the assembly: assemble the **corner bracket** formed by two **tray/middle brackets** (with 2-3 hooks).

- A) Insert the hooks of the **brackets** (1) in the trapezoids of the **bracket** (2) (Fig.13). Use a nylon mallet.
- B) Mount the **safety screws (M6x10 ISO7380)** between the **brackets** to prevent them coming out of the trapezoids (Fig. 14).

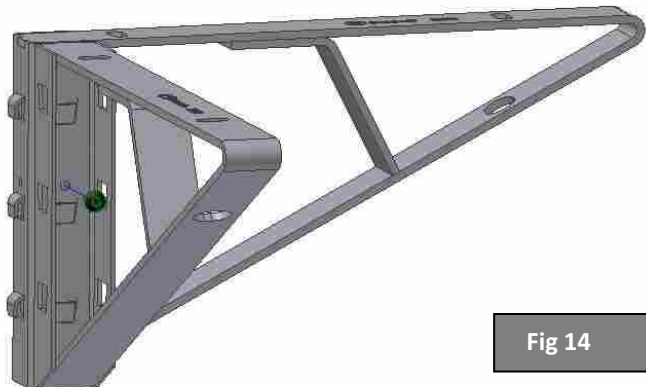
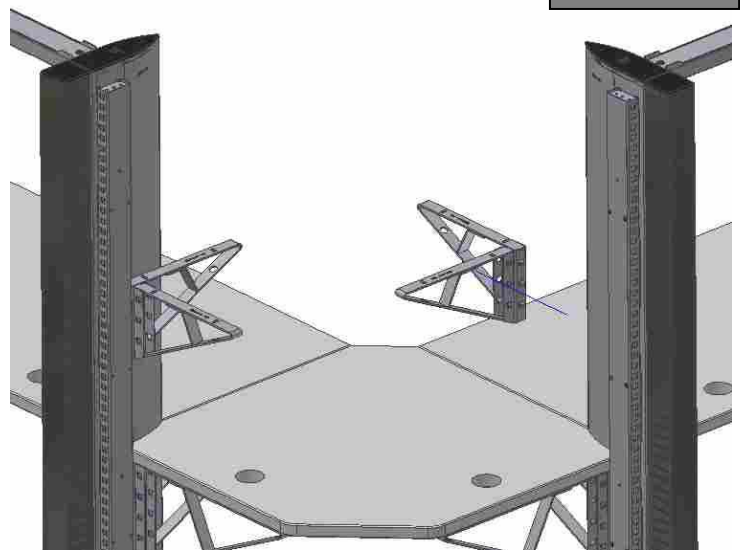

Fig 14

i The tops of the two **brackets** must be on a level for the placement of the **tables** or **shelves**.

Fig 15

STEP 2: A) Insert the hooks of the **corner bracket** in the trapezoids of the **grooved bar** (Fig. 15). Use a nylon mallet.



B) Mount the **safety screws (M6x10 ISO7380)** of the **brackets** to prevent them coming out of the trapezoids (Fig. 16).

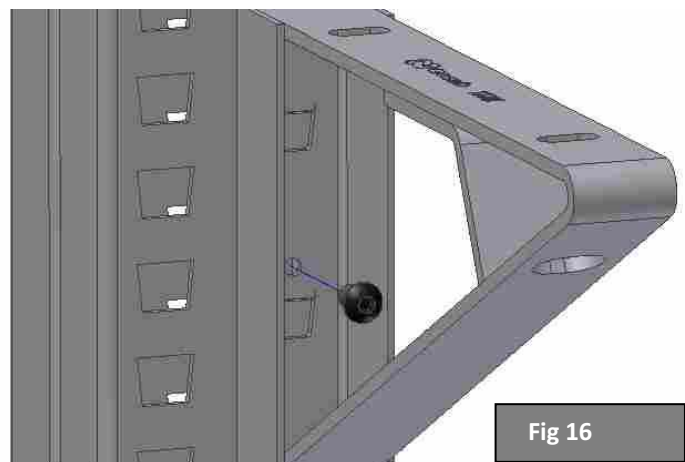

Fig 16

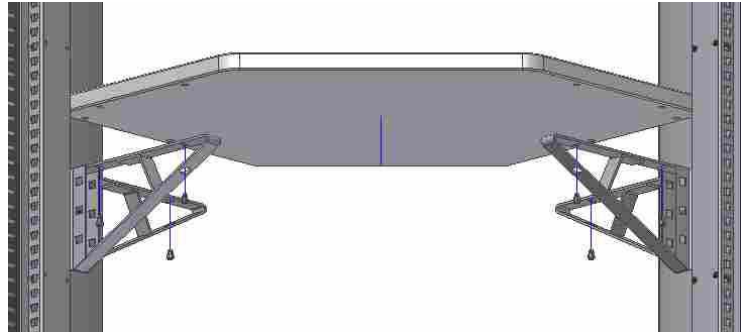

Fig 17

STEP 3: Position the **tray** and then join the **corner shelf** to the **corner brackets** from below using **M6x12 DIN785 Phillips screws** (Fig. 17-18).

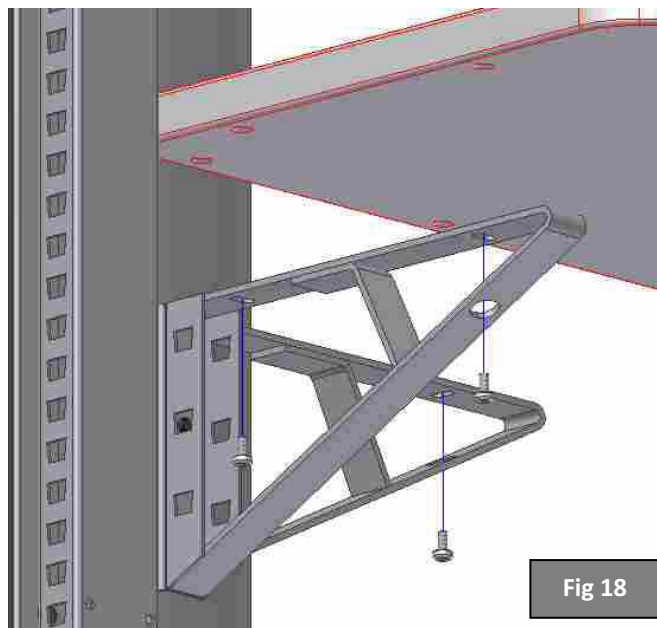

Fig 18

Duct Assembly Instructions

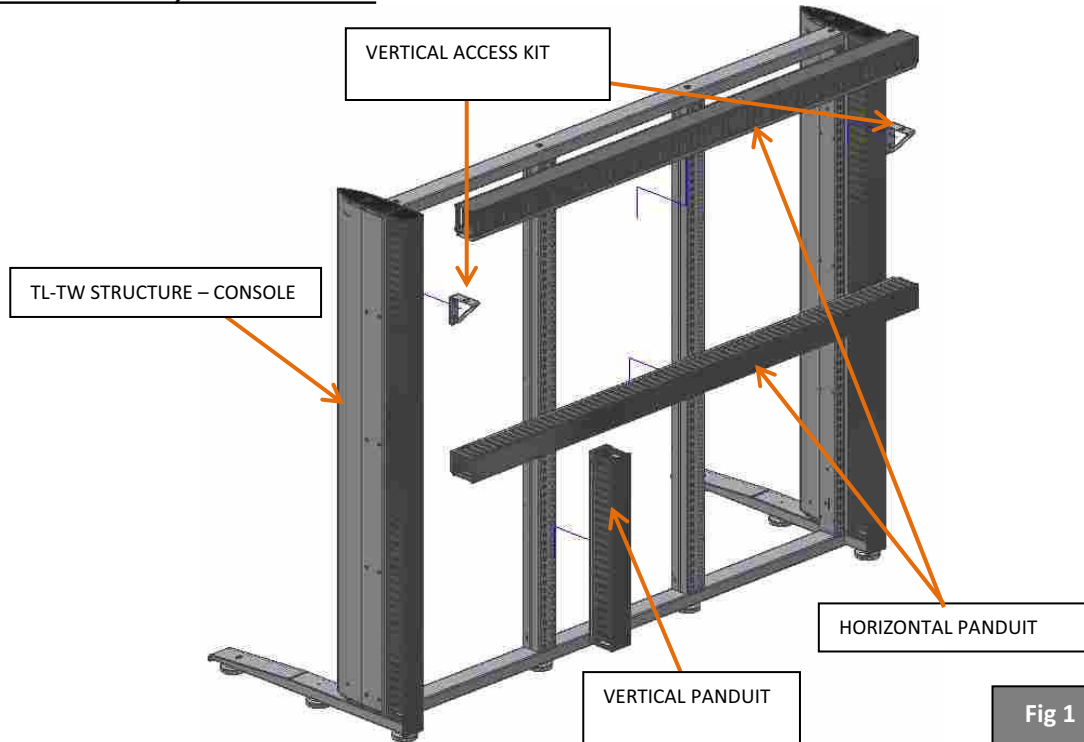

Fig 1

Assembly process Graphic assembly process



- Ducts valid for all products, **TL-TW** and **console**.
- Height adjustable in any position.
- Because of their assembly, whenever several **ducts** are required one over another, you must always assemble them from the bottom upwards.
- Can house **terminal blocks (570-2-0008/9008)**
- Usually located behind and accessory (**trays, tables, etc.**) for routing cables (Fig.2).

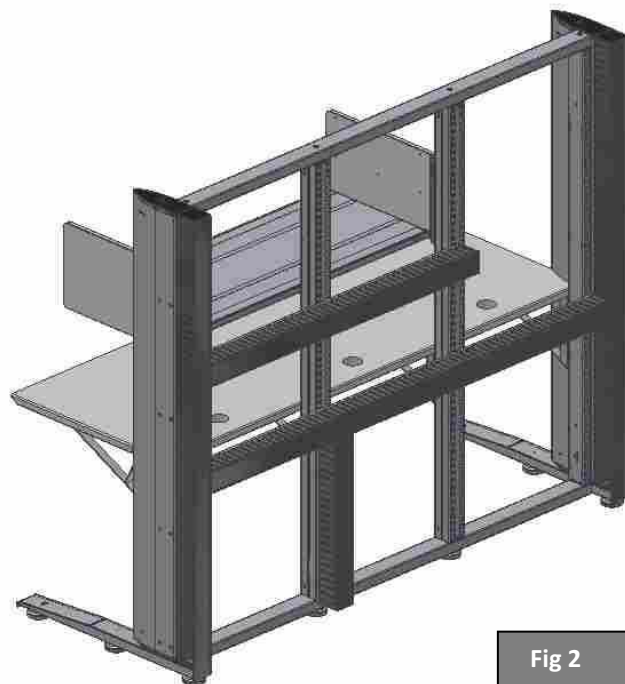

Fig 2

VERTICAL DUCTS:

STEP 1 – Insert the hooks of the **duct** in the trapezoids of the **double grooved bars** (Fig. 3 and 4). Use a nylon mallet.

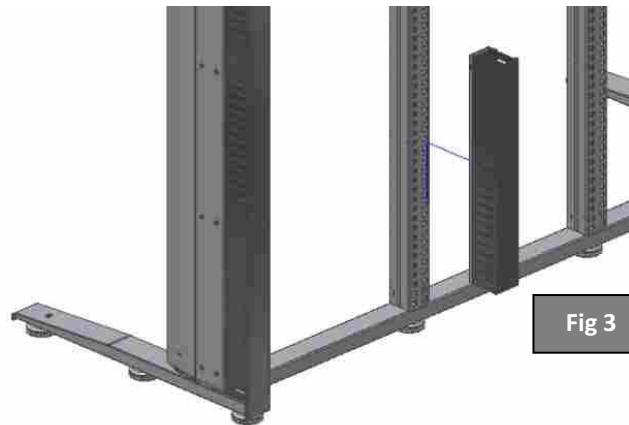

Fig 3

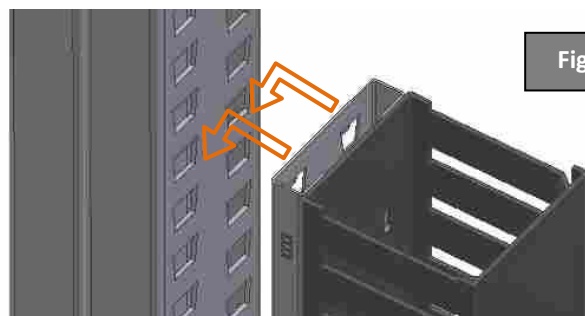

Fig 4

HORIZONTAL DUCTS:

STEP 1 – Insert the hooks of the **duct** in the trapezoids of the **grooved bars** (Fig. 5 and 6). Use a nylon mallet.

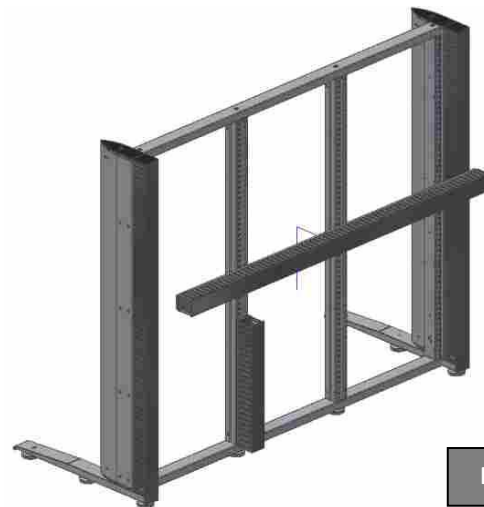

Fig 5

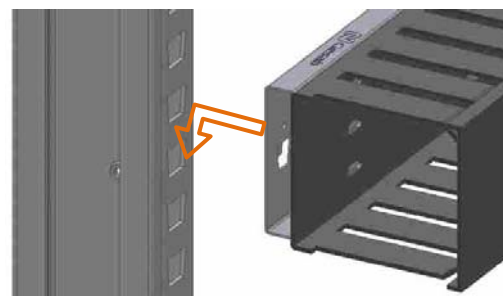

Fig 6



The **duct covers** are detachable.

VERTICAL ACCESS KIT:

STEP 1 – Insert the hooks of the **kits** in the trapezoids of the **grooved bars** (Fig. 7). Use a nylon mallet.

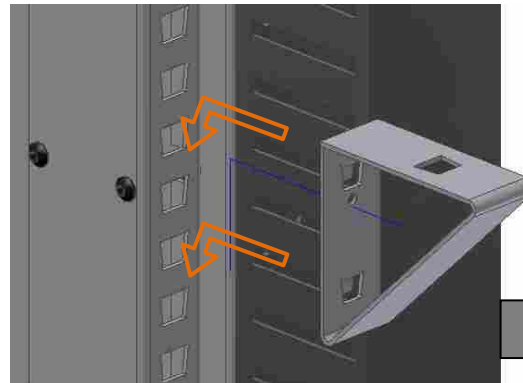

Fig 7

STEP 2 - Mount the **safety screws (M6x10 ISO7380)** of the **kits** to prevent them coming out of the trapezoids (Fig. 8).

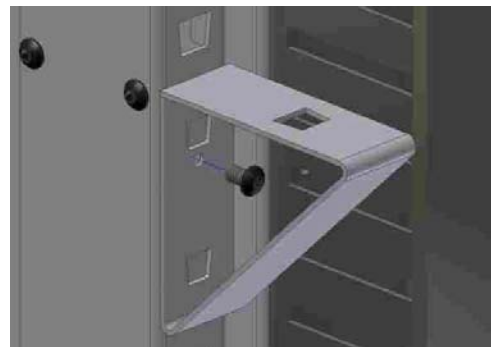

Fig 8

STEP 3 – Insert the hooks of the **horizontal ducts** in the trapezoids of the **kits** (Fig.9).

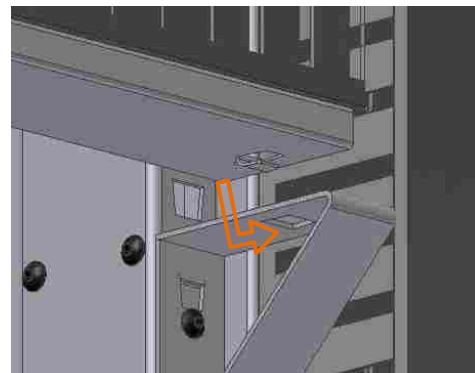

Fig 9

STEP 2 - Mount the **safety screws (4.9x13mm threaded screw-locks)** to prevent the **ducts** coming out of the trapezoids (Fig. 10).



Fig 10



Kits are only mounted with **horizontal ducts**.

Support Kit Assembly Instructions

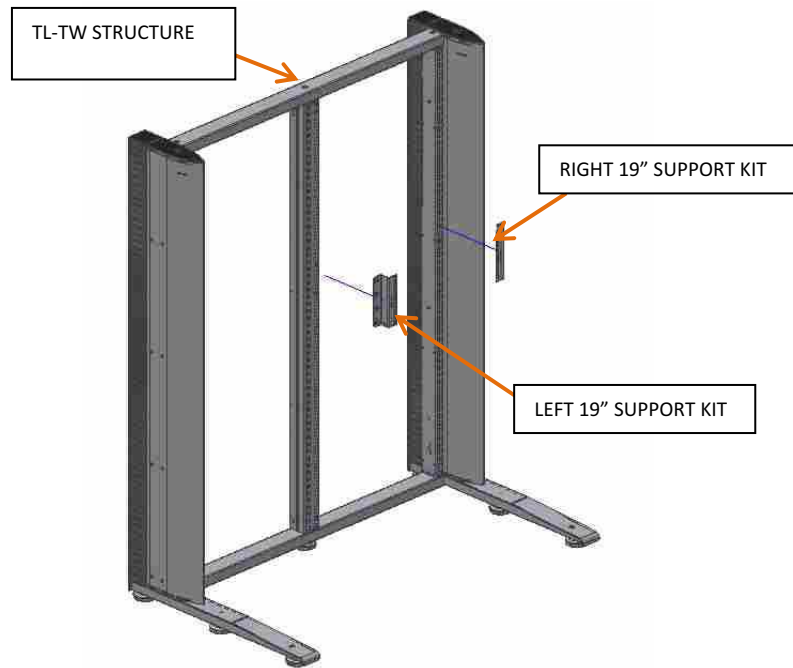

Fig 1

Assembly process | Graphic assembly process



The **19" support kit** can be mounted either at the front or back of any **frame**. There are kits for both 600 and 800mm sections.

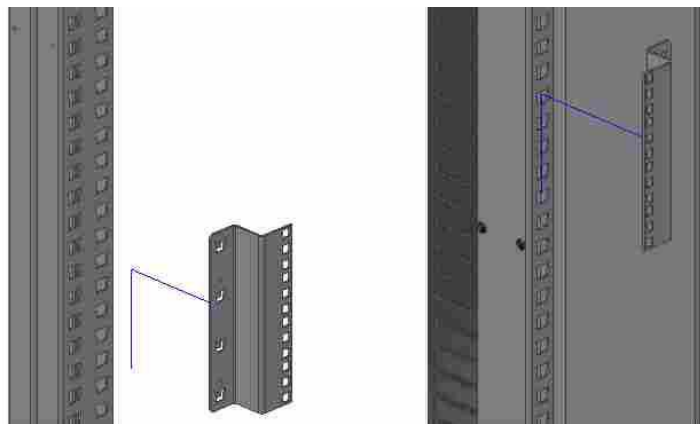
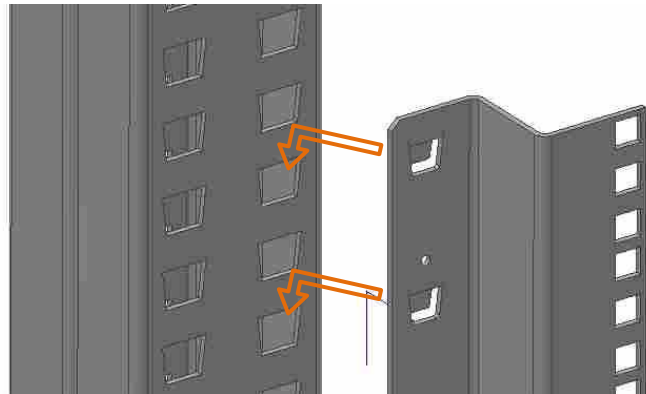

Fig 2

STEP 1 – Insert the hooks of the **19" support kit** in the trapezoids of the **frames** (Figs. 2 and 3).
Use a nylon mallet.

Fig 3



STEP 2 - Mount the **safety screws (3.9x13mm threaded screw-locks)** of the **19" support kits** to prevent them coming out of the trapezoids (Fig. 4).

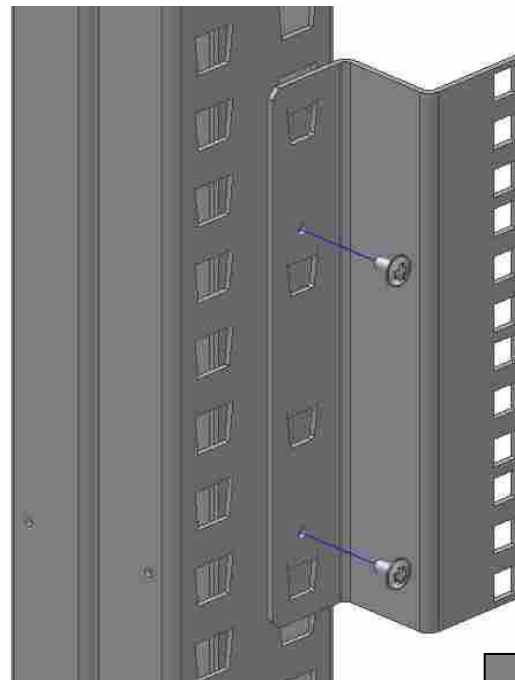

Fig 4

19" Socket Base Assembly

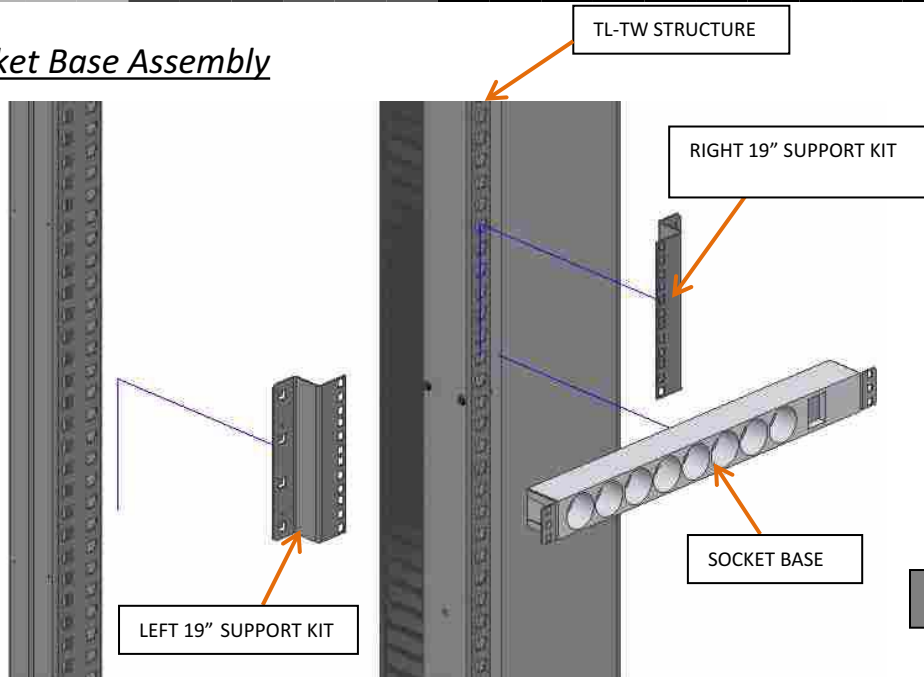

Fig 1

Assembly process

Graphic assembly process



The **19" socket base** can be mounted either at the front or back of any **frame** and be adapted to both 600 and 800mm sections. It can also be mounted in any PVC **duct**.

STEP 1 – Before installing the **19" socket base**, the **19" support kit** must be preassembled (Fig.2). (See chapter 13).

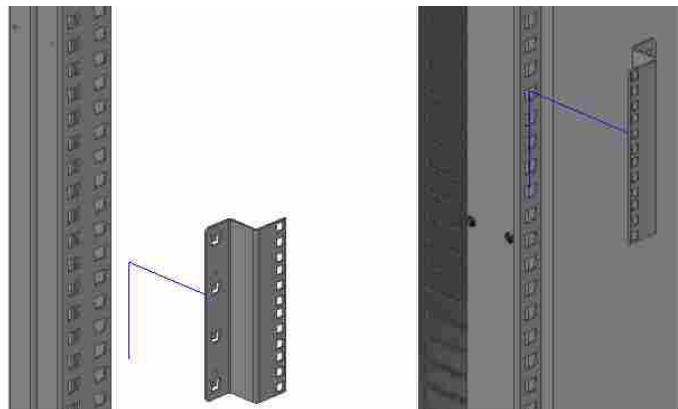
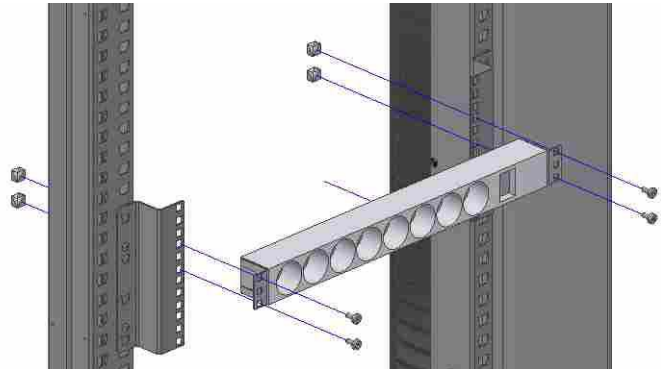

Fig 2

Fig 3



STEP 2 – Mount the 4 **M6 caged nuts** on one of the U's of the **19" support kit** (Fig.4). Next screw on the **19" socket base** using 4 **M6x12 DIN785 Phillips screws** (Fig.5).

Fig 4

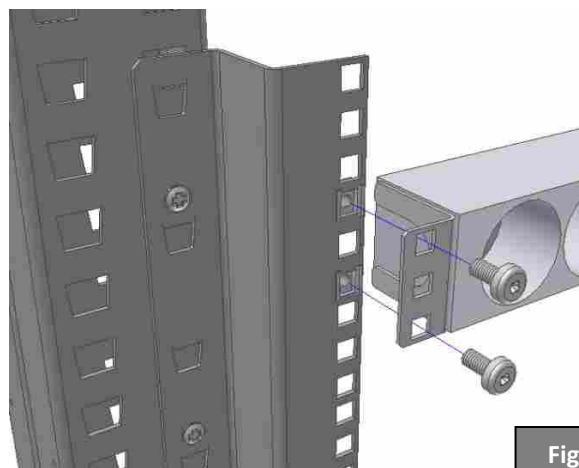
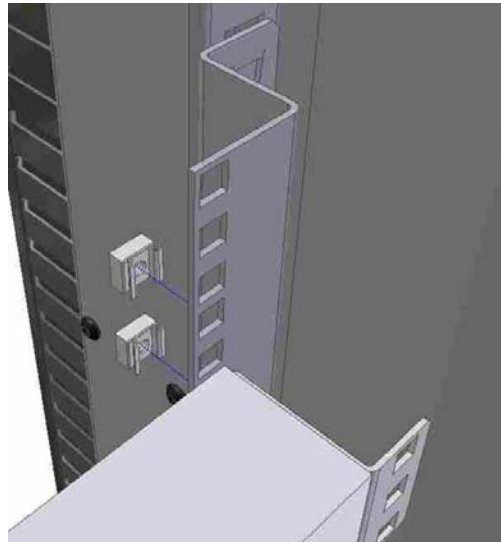

Fig 5

19" Duct Assembly Instructions

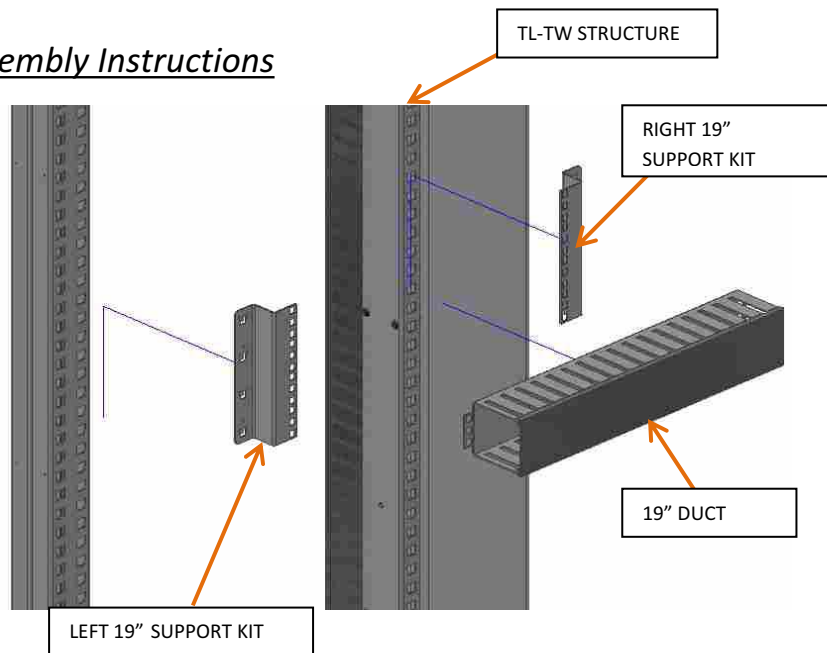

Fig 1

Assembly process Graphic assembly process



The **19" duct** can be mounted either at the front or back of any **frame** and be adapted to both 600 and 800mm sections.

STEP 1 – Before installing the **19" duct**, the **19" support kit** must be preassembled (Fig.2). (See chapter 13).

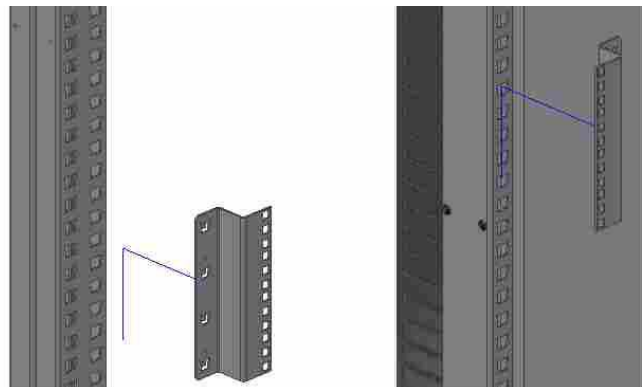

Fig 2

Fig 3

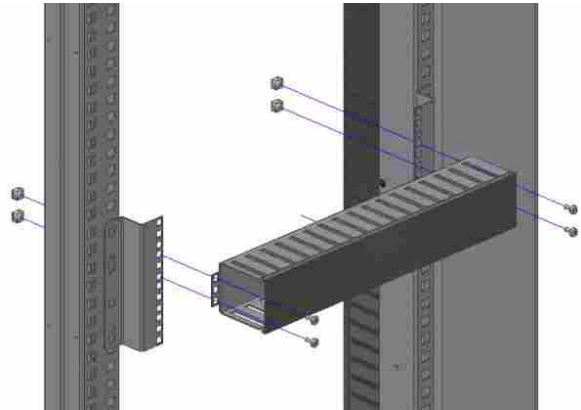

Fig 4

STEP 2 – Mount the 4 **M6 caged nuts** on one of the U's of the **19" support kit** (Fig.4). Next screw on the **19" duct** using 4 **M6x12 DIN785 Phillips screws** (Fig.5).

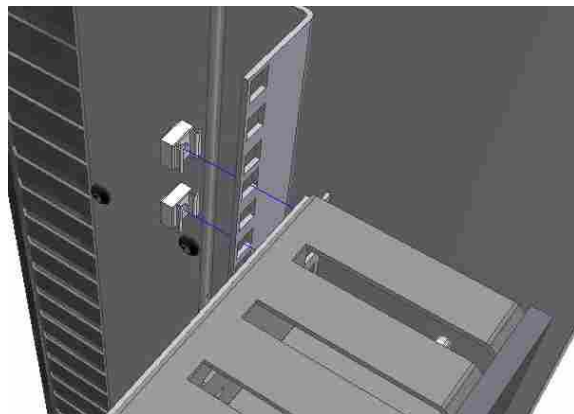
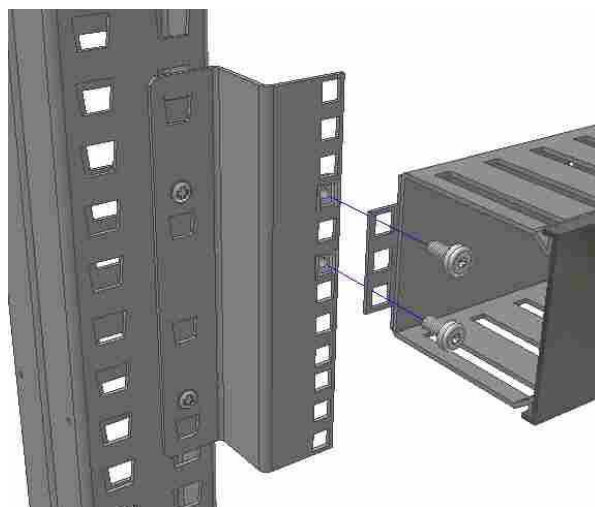

Fig 5



19" Rack Compartment Assembly

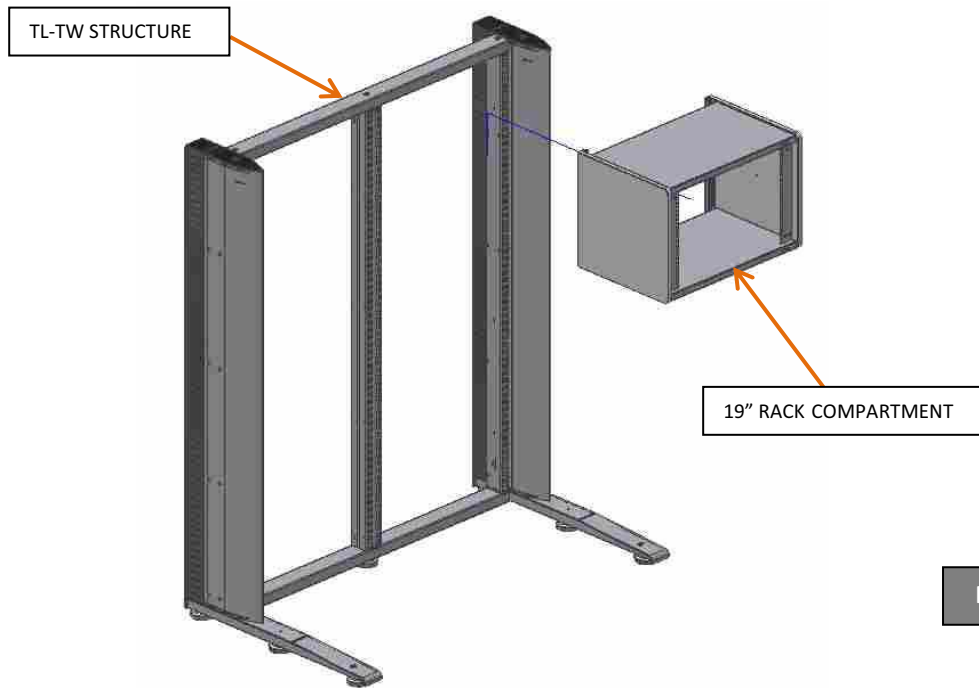

Fig 1

Assembly process Graphic assembly process

STEP 1 – Insert the hooks of the rack compartment in the trapezoids of the frames (Fig.2). Use a nylon mallet.



Fig 2

Compartment Assembly Instructions

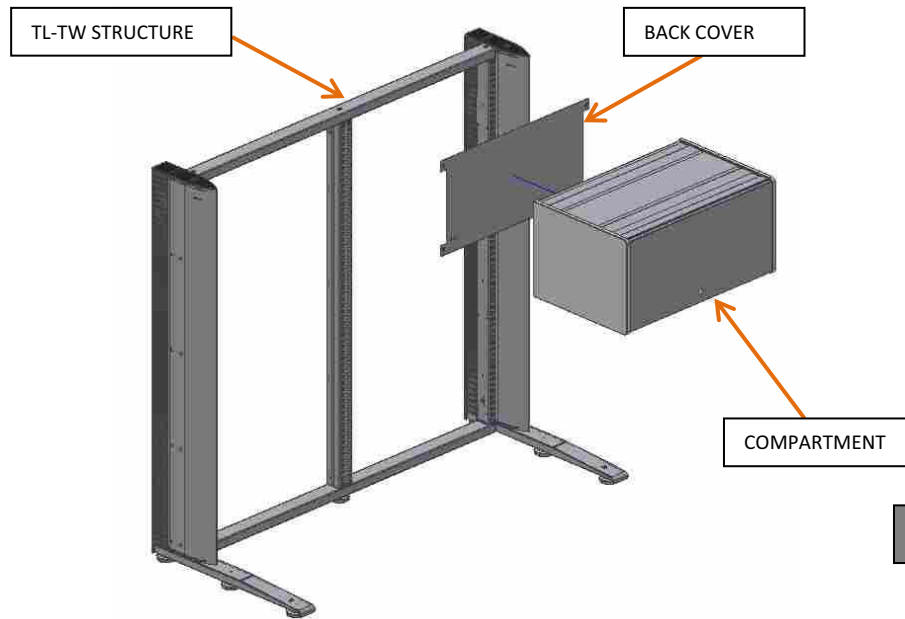

Assembly process

Graphic assembly process

STEP 1 – Insert the hooks of the rack compartment in the trapezoids of the frames (Fig.2). Use a nylon mallet.

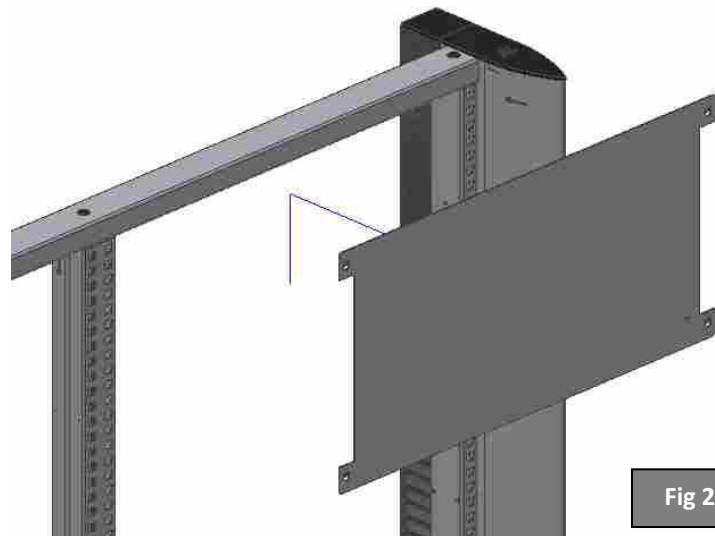

Fig 3

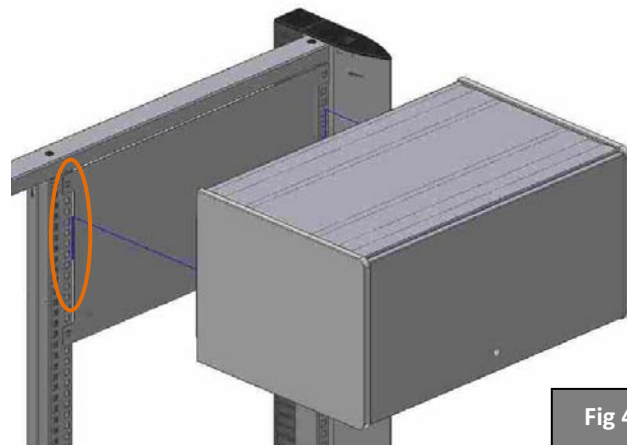
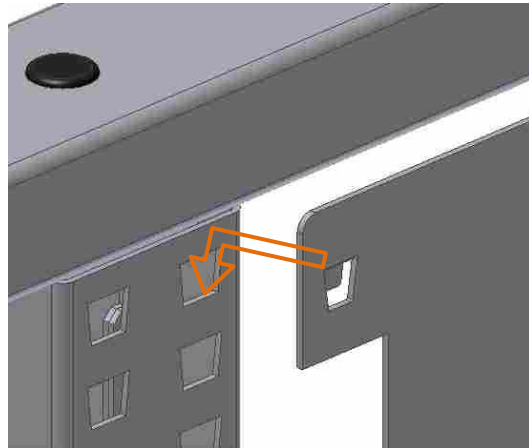

Fig 4

STEP 2 – Insert the hooks of the **compartment** in the trapezoids of the **frame** in the middle area of the **back cover** which is free (Fig.4 and 5).
Use a nylon mallet.

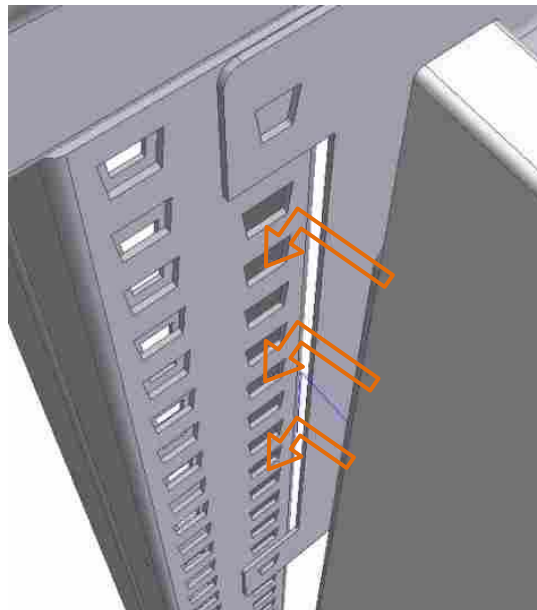

Fig 5

19" Rack Side Assembly Instructions

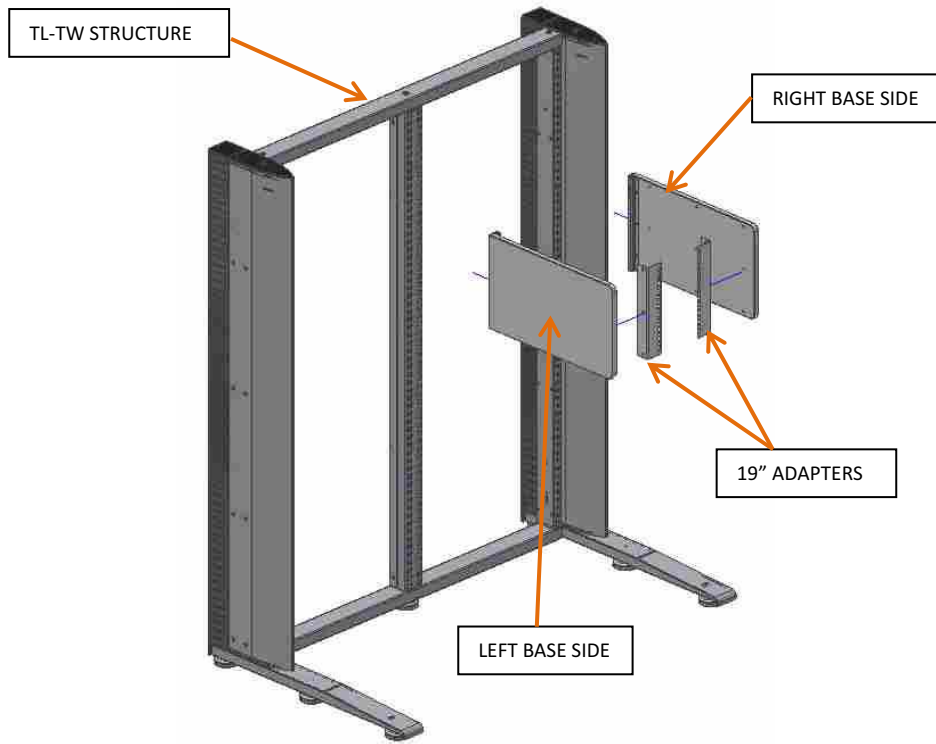

Fig 1

Assembly process | Graphic assembly process



There are **19" adapters** for both 600 and 800mm sections.

STEP 1 – Insert the hooks of the **base sides** in the trapezoids of the **frames** (Fig.2 and 3).
Use a nylon mallet.

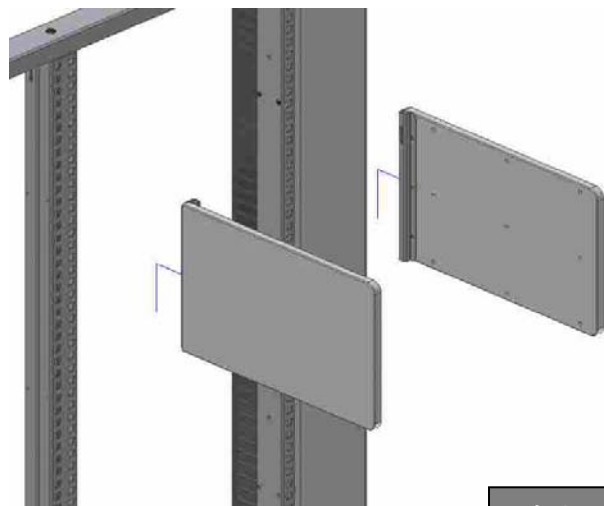

Fig 2

Fig 3

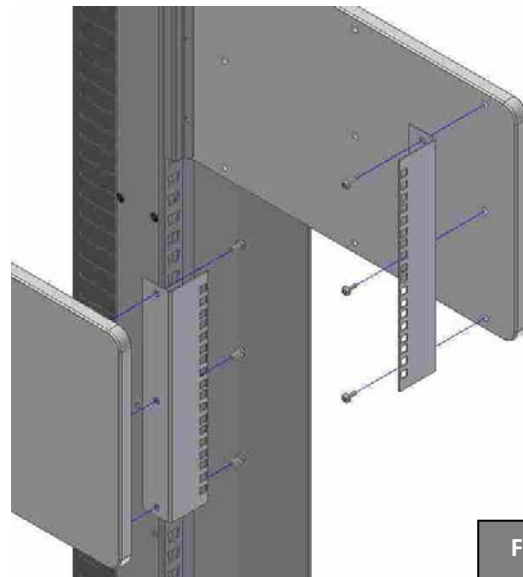

Fig 4

STEP 2 – Place the **19” adapters** on the first column of the **base sides**. Then screw them together using **M5x12 DIN785 Phillips screws** (Fig. 4 and 5).

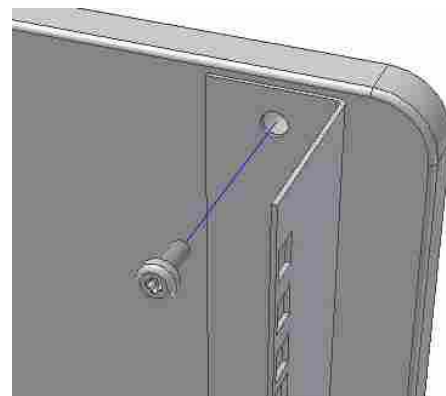

Fig 5

Wall Rack Assembly Instructions

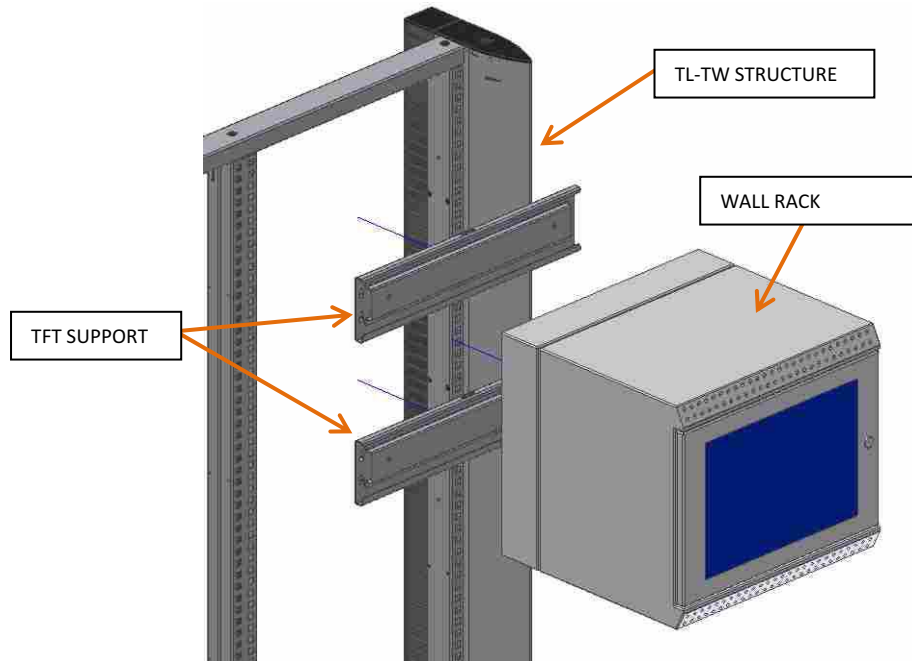

Fig 1

Assembly process

Graphic assembly process



The **wall rack** is only used in **600mm** sections.

STEP 1 – Mount the **TFT supports** on the **grooved bars** (see assembly in chapter 21) (Fig.2). The total distance between **TFT supports** is the same as the full height of the **wall rack**.

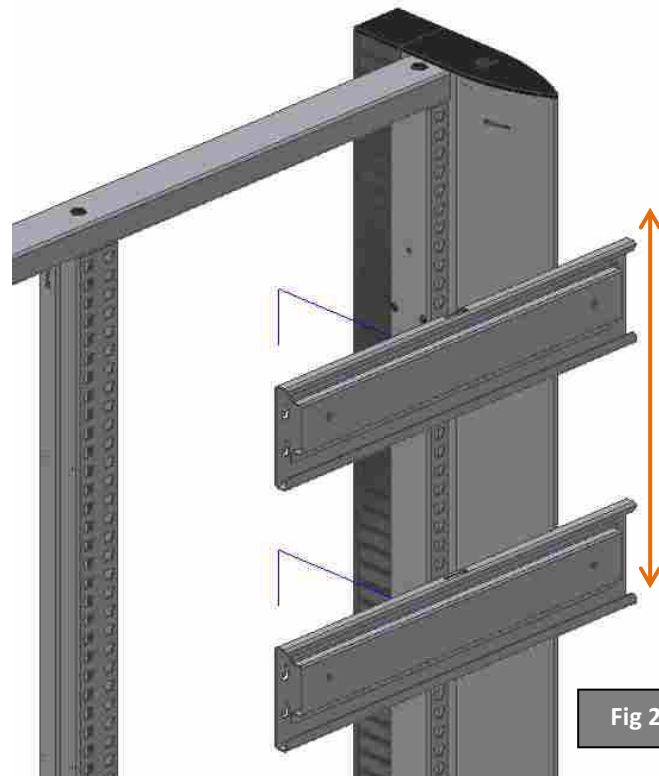

Fig 2

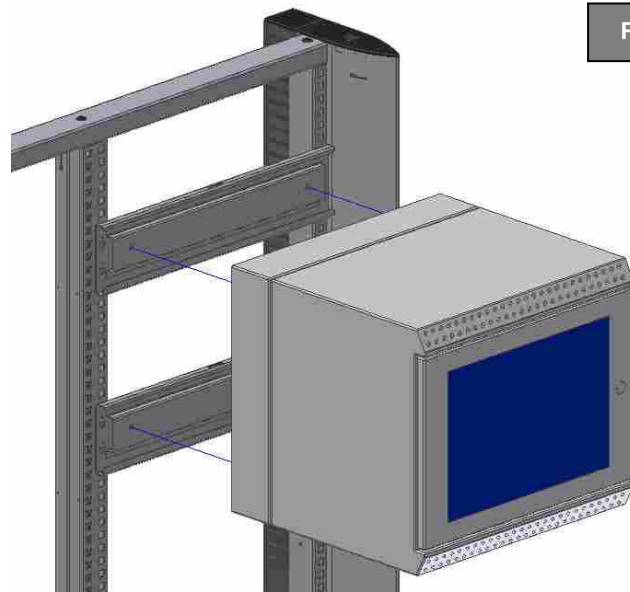

Fig 3

STEP 2 – Mount the **wall rack** on the **TFT supports** and fasten it from the inside with 4 **M6x12 DIN785 Phillips screws** (Fig. 3 and 4).

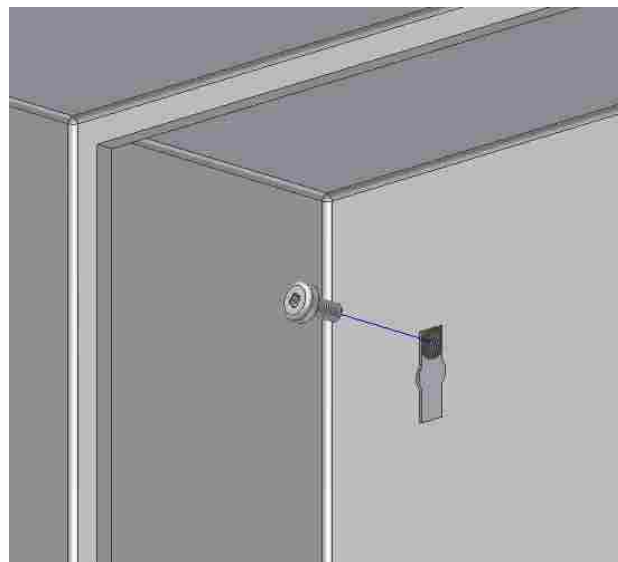

Fig 4

Panel Assembly Instructions

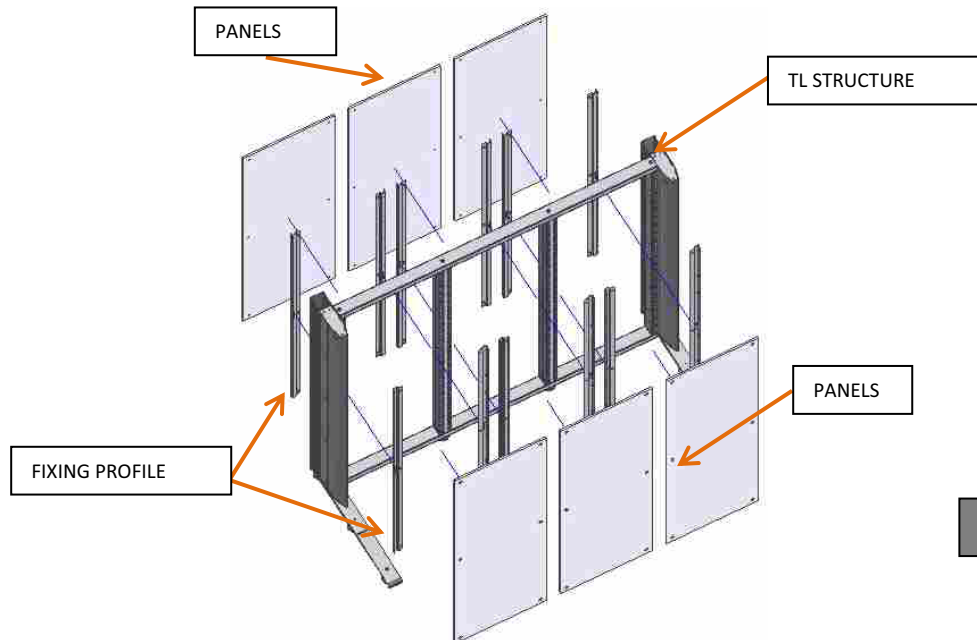

Fig 1

Assembly process

Graphic assembly process



- The **double panel** always goes in the **600** or **800mm** sections.
- Always mount one **panel** after another, not the two **panels** of the same section at the same time.
- The only height which is not manufactured is **740mm**.
- To mount the panels, it is not necessary to dismount a structure; they can be mounted afterwards.

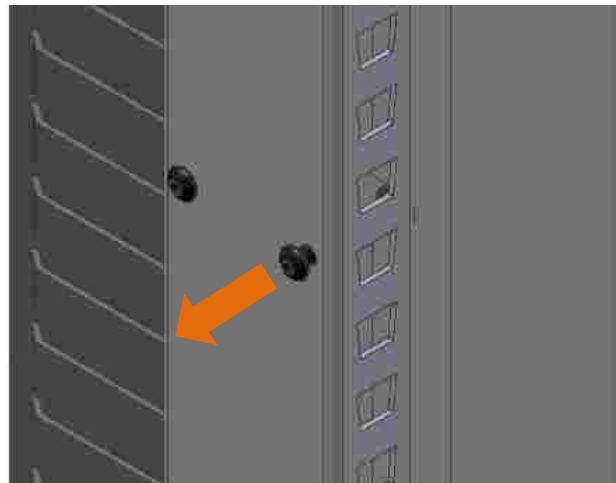

Fig 2

STEP 1 – Before mounting the **fixing profile** of the **panels**:

- In the single **grooved end bar** of the **frames**, loosen one row of **M6x45 ISO7380 Allen screws** (Fig.2).

Fig 3

-On the **middle double grooved bar** of the **frames**, screw in the **3.9x13mm threaded screw-locks** directly (Fig.3) or machine the holes for the **ISO7380 Allen screws** (Fig.4).

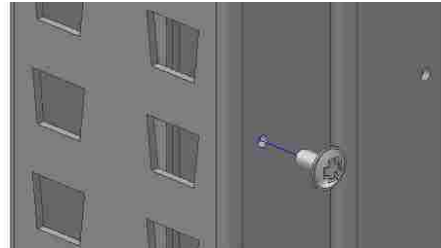
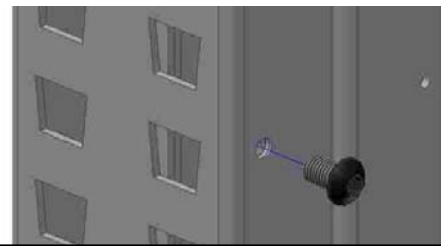

Fig 4



Do not fully tighten; leave some play in order to later place the fixing profile.

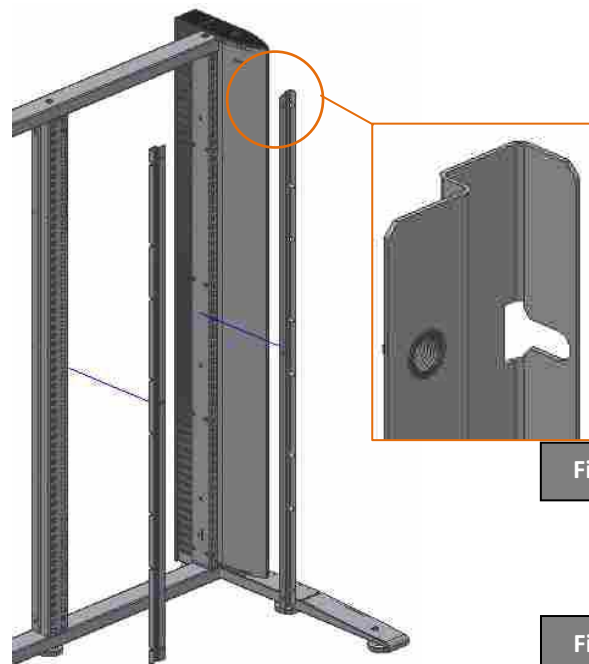

Fig 6

Fig 5

STEP 2 – Place the **fixing profiles** of the **panel** being mounted (Fig.5). The screw heads pass through the slots in the **profiles** (Fig. 6 and 7). Then tighten all the screws.



Fig 7

STEP 3 – Insert the **panel** in the **frame** section (Fig.8). Assemble the **panel** to the **fixing profiles** using the **M8x16 DIN7991 countersunk Allen screws + M8 grommet** (Fig.9).

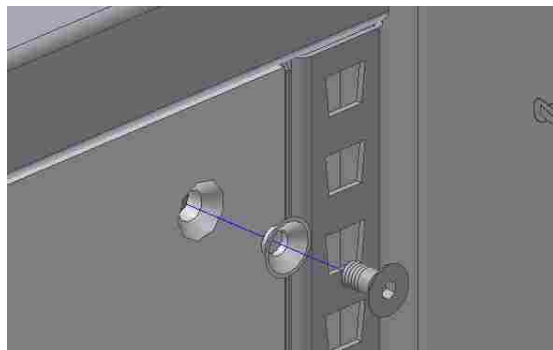
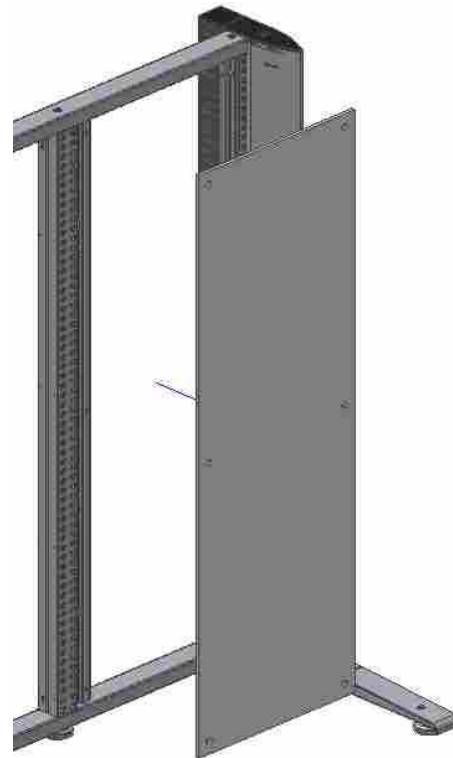

Fig 9

STEP 4 – Mount the **panel** of the same section but on the other side (Fig.10). Mount the **panels** in each section successively in the same way.

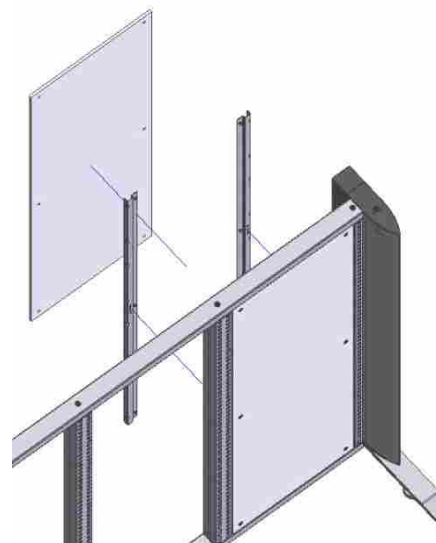

Fig 10

WALL BOX MOUNTING

STEP 1 – Break off the **stamped inlets** for wiring.



STEP 2 – Make the corresponding cut in the **panel** according to the number of modules of the box.

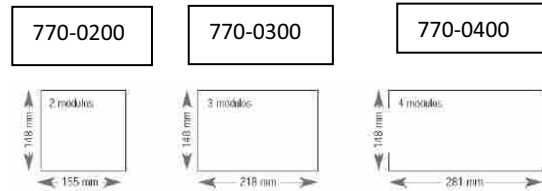

STEP 3 – Pass the wires on to the inside of the box. Attach it using the **fixing claw**.

The flap of the **box** should remain on the surface of the wall.

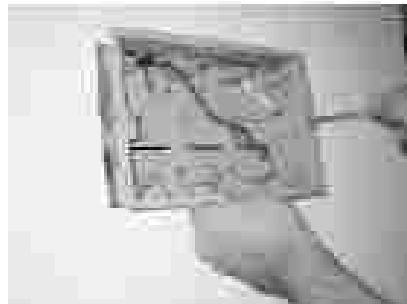

STEP 4 – Wire and mount the circuit breaker to the DIN guide.



STEP 5 – Wire the **bases** to the **terminals** and fix the **power bases** to the **guides**.



STEP 6 – Wire the **bases** to the **terminals** and fix the **power bases** to the **guides**.

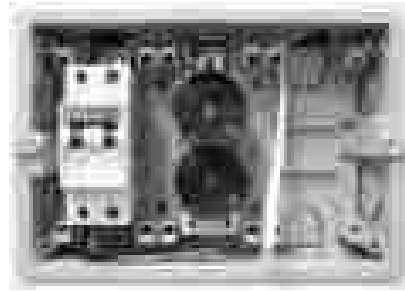

STEP 7 – Insert the **connectors** in the corresponding **data plates**.



STEP 8 – Fix the **plates** to the **turrets**.
To remove a **plate**, push the **end clips** and lift the **plate**.



STEP 9 – Mount the **trim frame** and fasten it by pressing and turning the plastic screws through 90°.



In **wall boxes** with **cover**, the **circuit breakers** are installed without a **cover**.



TFT Support Assembly Instructions

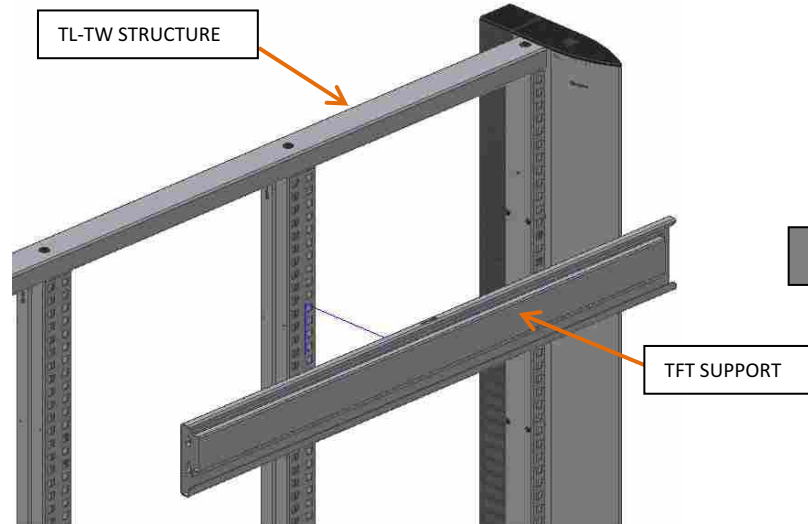

Fig 1

Assembly process Graphic assembly process

STEP 1 – Insert the hooks of the **TFT support** in the trapezoids of the **frames** (Fig.2).
Use a nylon mallet.

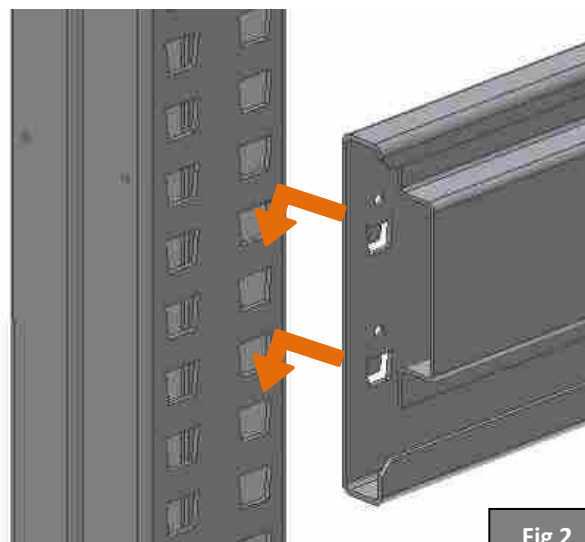

Fig 2

STEP 2 – Mount the **safety screws (M6x10 ISO7380 Allen screws)** of the **TFT supports** to prevent them coming out of the trapezoid (Fig. 3).

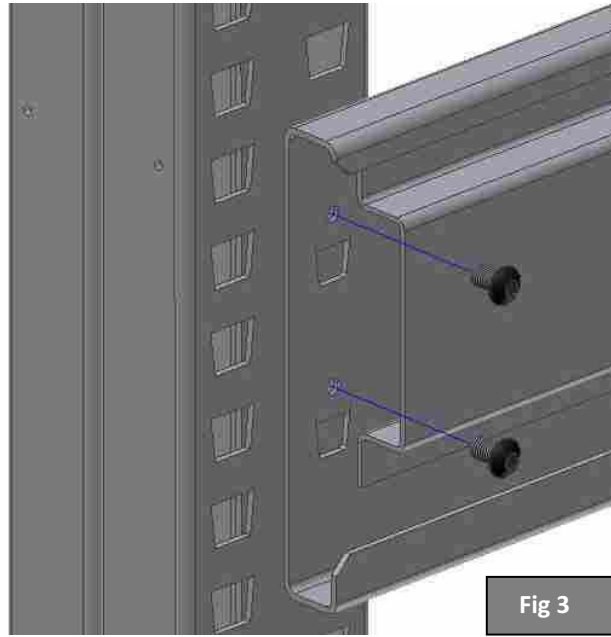

Fig 3

Console Assembly Instructions

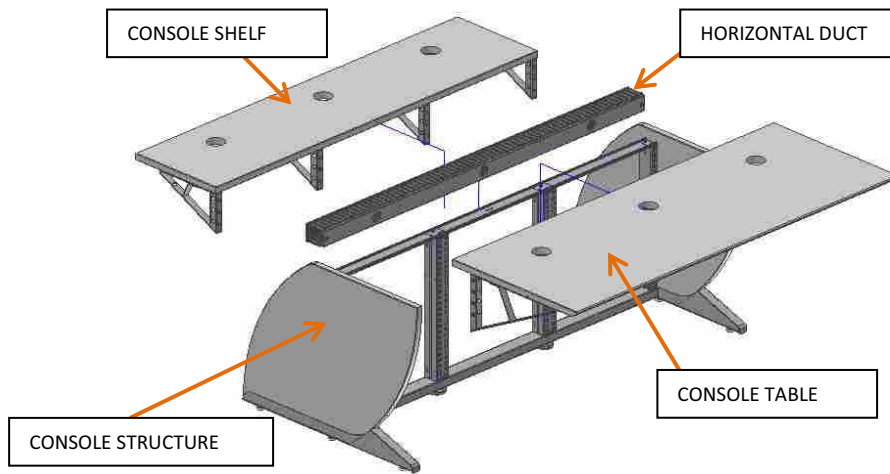

Fig 1

Assembly process | Graphic assembly process



Follow this assembly process when you wish to keep the **horizontal duct** between the **console shelf** and **table**.

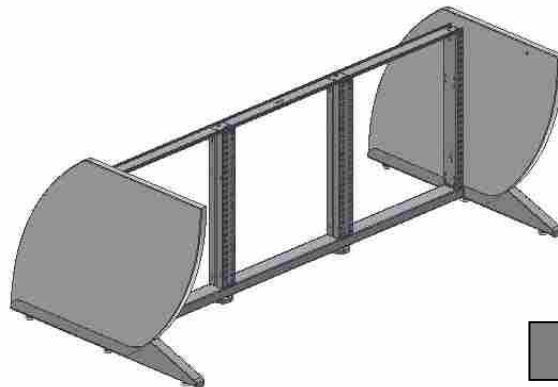

Fig 2

STEP 1. – Assemble the **console structure**, i.e. **console base frame** with **agglomerate console sides** (Fig.2) or **standard metal TL-TW sides** (Fig. 3).

See assembly chapters:
Base side + frame (4)
Console side (23)
Frame (3)

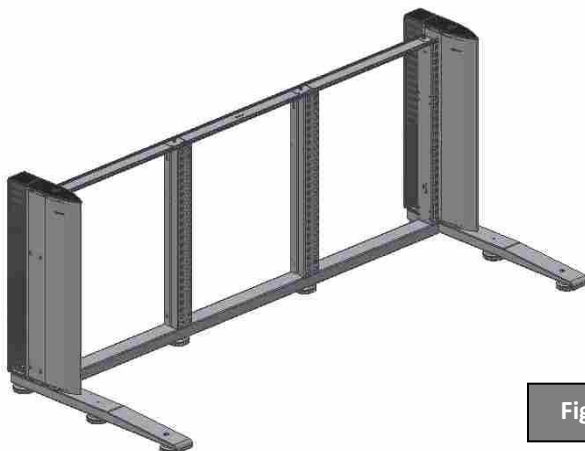

Fig 3

STEP 2 – Mount the **console shelf** with its **brackets** to the **base frame** of the **console** at the back (Fig.4).

See assembly chapter:
Console shelf (24)

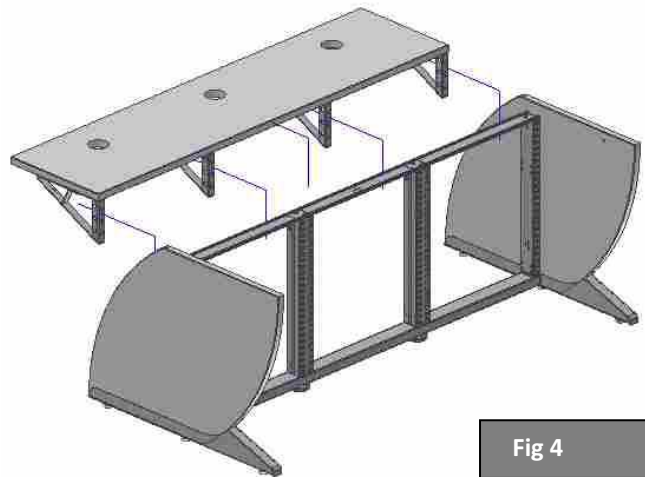

Fig 4

STEP 3 – Insert the hook of the horizontal duct in the first trapezoid of the base frame at the back (Fig. 5).

See assembly chapter:
Ducts (15)

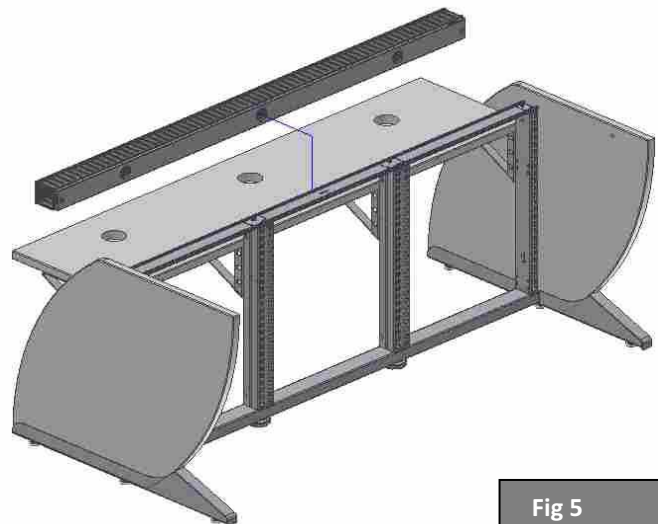

Fig 5

STEP 4 - Mount the **table** with its **brackets** to the **base frame** of the **console** at the front (Fig.6).

See assembly chapter:
Tables (24)

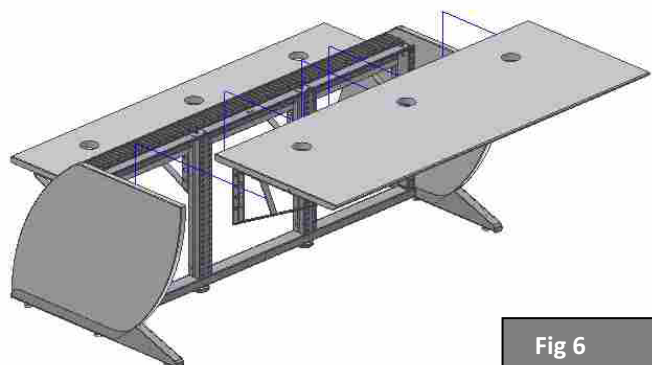
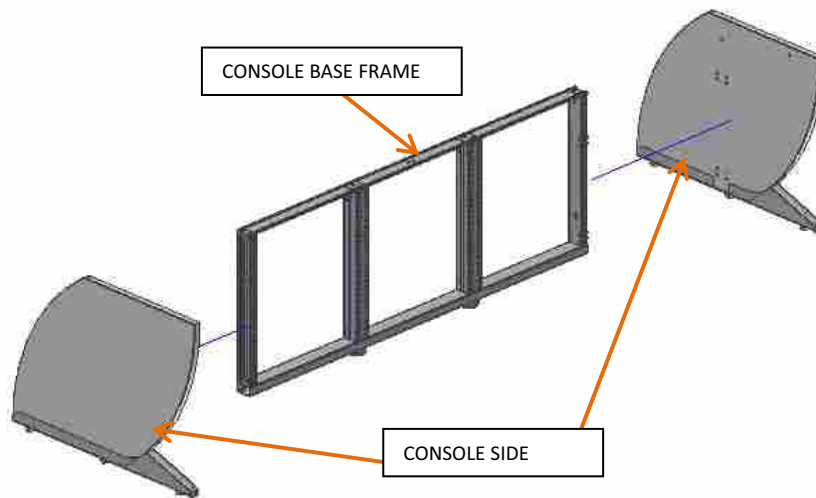

Fig 6

Console Side Assembly Instructions



Assembly process

Graphic assembly process



This **side** is only mounted in **specific console frames**, i.e. **740mm height**. The **console** can use these **sides** or the **standard 740mm** of the TL-TW.

STEP 1 – Position the centre of the **console side** at the end of the **console frame** and then screw it in place with **9 M6x45 ISO7380 Allen screws** (Fig.2).

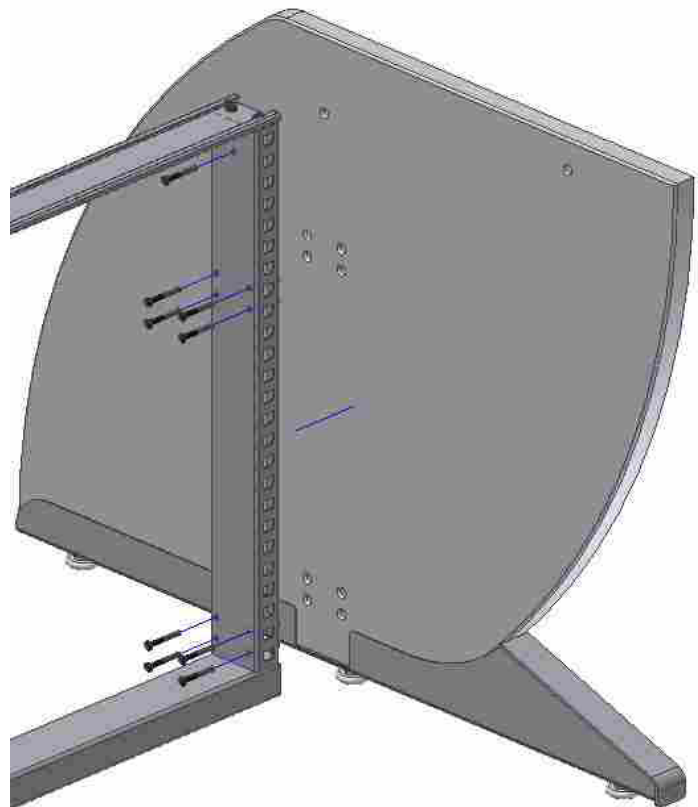

Fig 2

Console Shelf Assembly Instructions

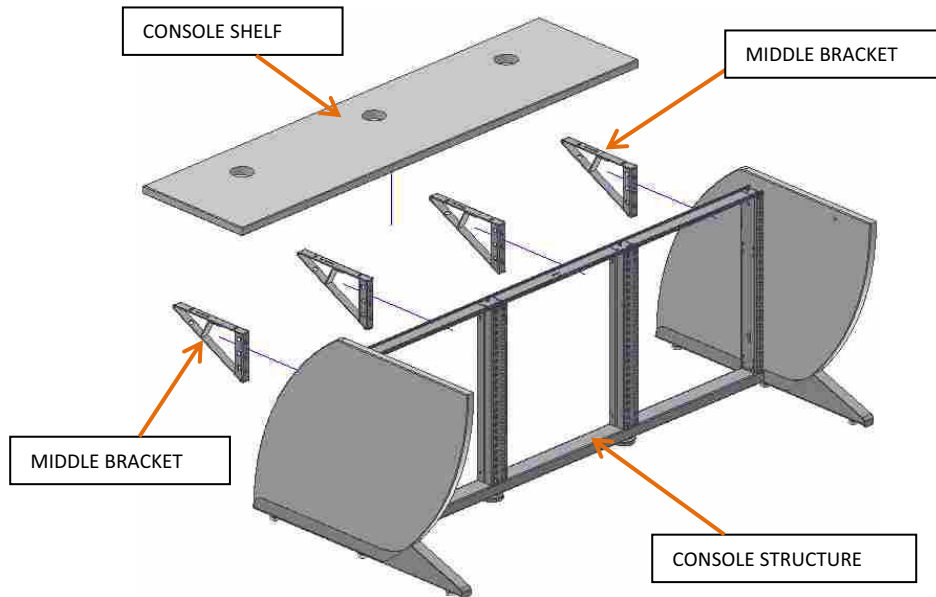

Fig 1

Assembly process | Graphic assembly process

i Shelves always use **middle brackets** (with 3 hooks).

See table below:

Shelf width	Nº middle brackets
600	2
800	2
1200	3
1600	3
1800	4
Angular	3

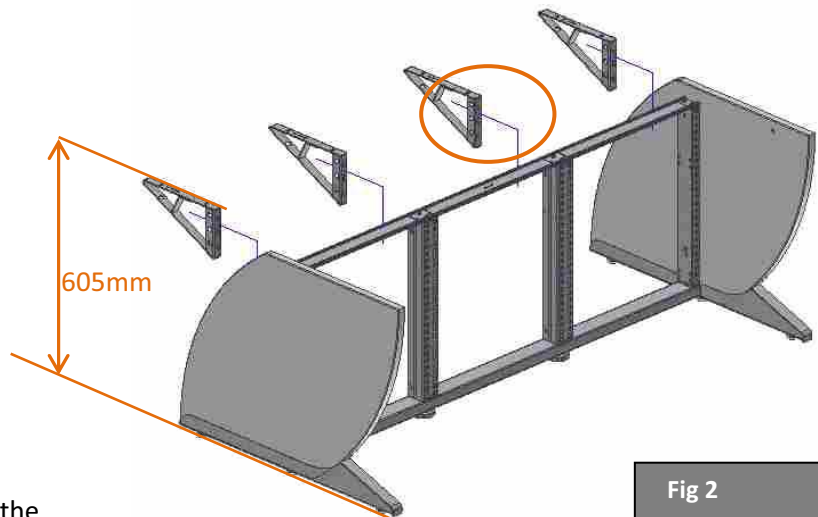
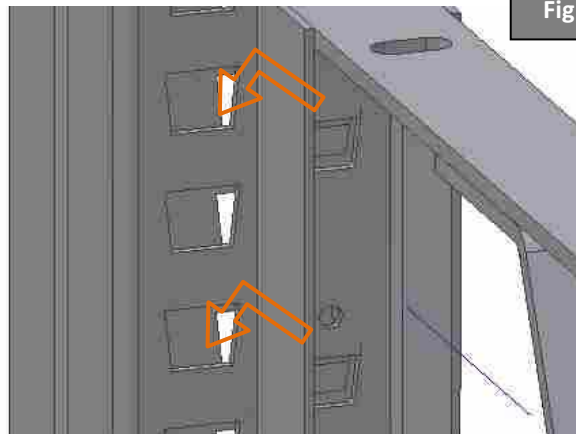

Fig 2

STEP 1 – Position the **brackets** on the **structure**, one on each **vertical bar** of the **frame**. In order to be able to place a **horizontal duct** between the **console shelf** and **table**, the top of the **brackets** must be 605mm from the floor (Fig.2) or, what amounts to the same, leave 3 full trapezoids of the **frame** visible at the top.

Insert the hooks of the **brackets** in the trapezoids of the **frames** (Fig.3).
Use a nylon mallet.



STEP 2 – Mount the **safety screws (M6x10 ISO7380)** of the **brackets** to prevent them coming out of the trapezoid (Fig. 4 and 5).

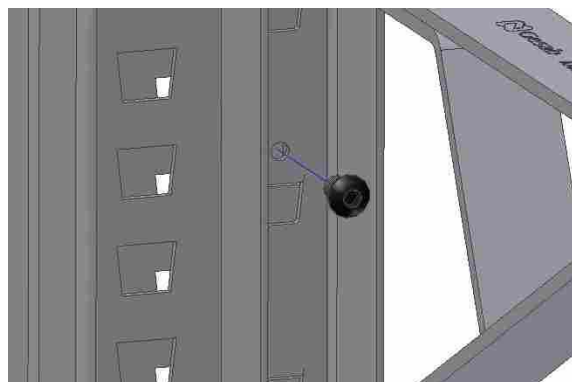
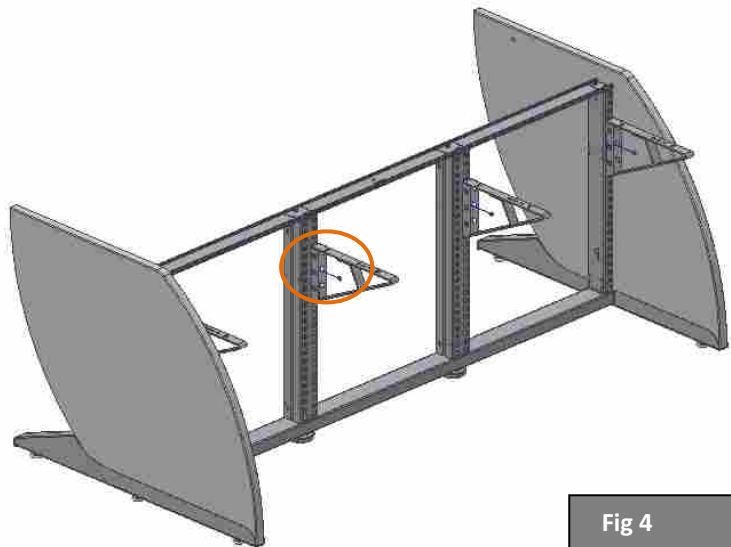

STEP 3 – Place the **console shelf** on the **brackets** and screw them from below with **NM6x12 DIN785 Phillips screws** (Fig. 6 and 7).

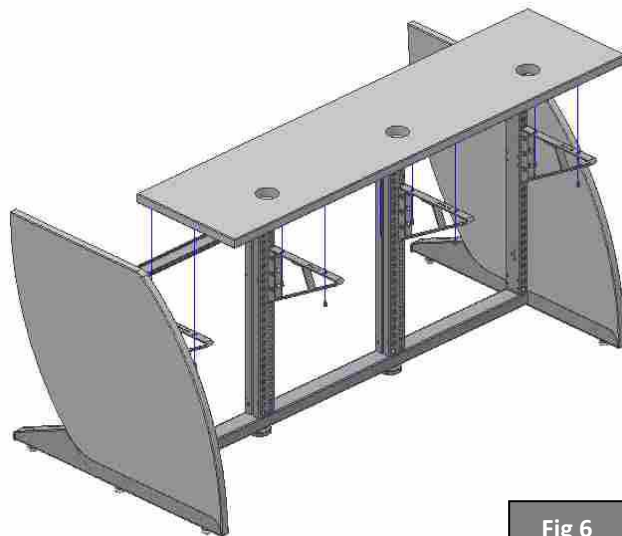

Fig 6

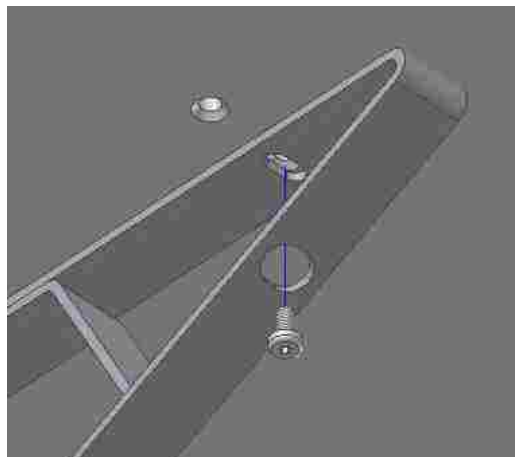

Fig 7

STEP 4 – When there are more than two **console shelves** one after the other, it is also necessary to mount the **crescent eccentrics** between them for better fitting and finish (Fig.8).

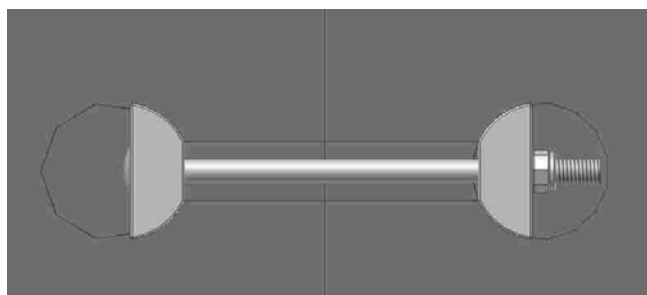
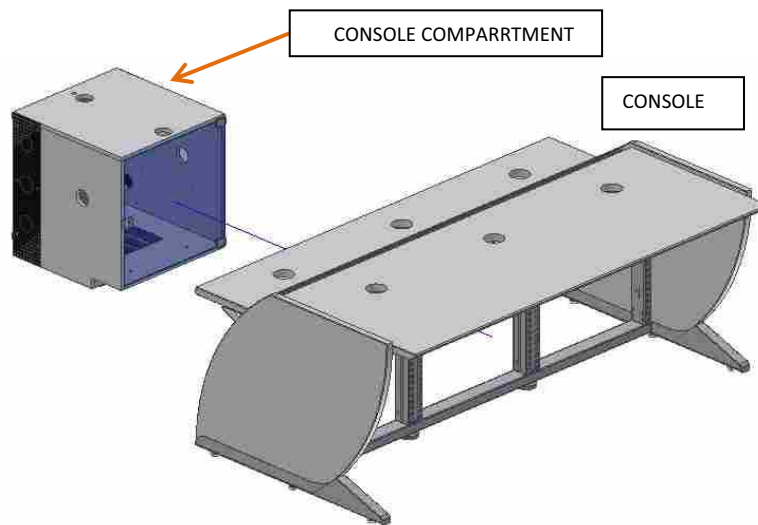

Fig 8

Console Compartment Assembly



Assembly process

Graphic assembly process



The minimum distance between the floor and the bottom of the **console shelf** in order to be able to place a **buck** beneath is 605mm.

Bucks are always mounted between the sections of the **base frames**.

STEP 1 – Differentiate the **buck**. The **side trim** is the key for knowing which side or type it is. If it has the two **trims** on both sides, it is an **individual compartment** (Fig.2). On the other hand, if it has no **trim**, it is a **middle compartment**, i.e. there will be another on either side because there are **ATS** (Fig.3). If it has a **trim** on one side only, it is either a left or right end **compartment**. On the side without **trim**, there will be another because there is **ATS** (Fig. 4 and 5).

Fig.2: Individual (660-2-0600)

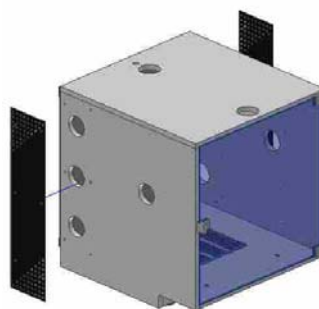

Fig.3: Middle (660-2-0630)

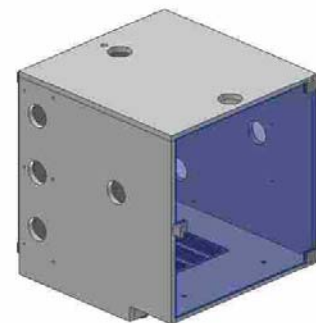

Fig.3: End left(660-2-0620)

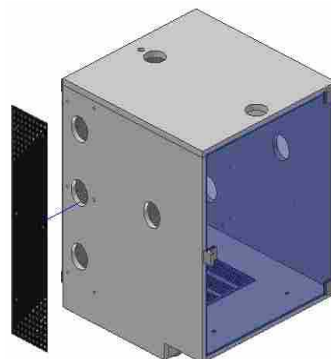
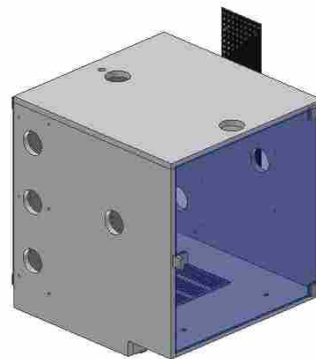

Fig.3: End right (660-2-0610)



STEP 2 – Insert the **console compartment** in the **frame section** until the bottom recess fits in place (Fig. 6 and 7).

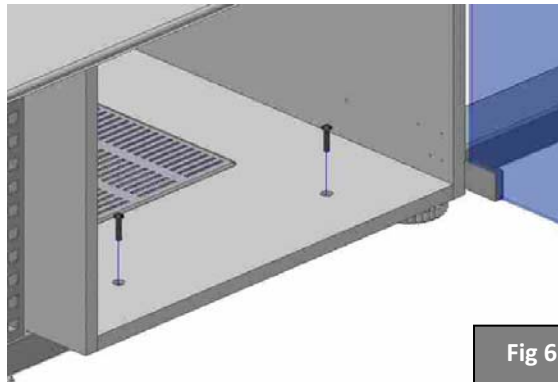

Fig 6

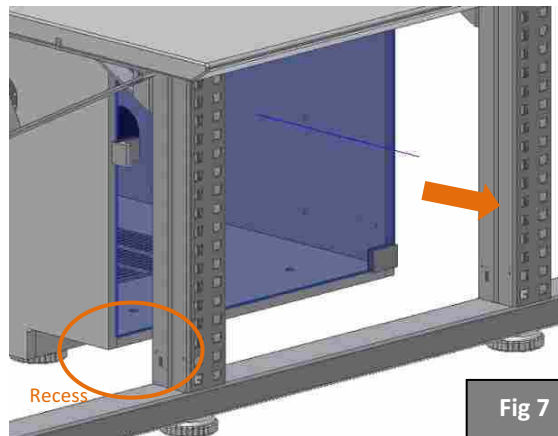

Fig 7

STEP 3 – Block the possible movement of the **compartment** with **2 M6x25 ISO7380 Allen screws** at the front (Fig.8).

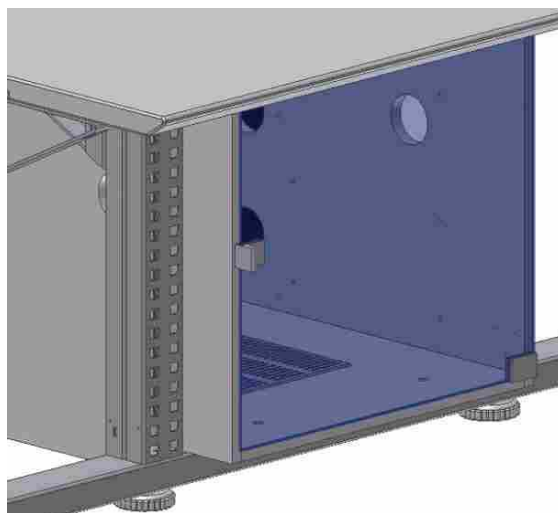
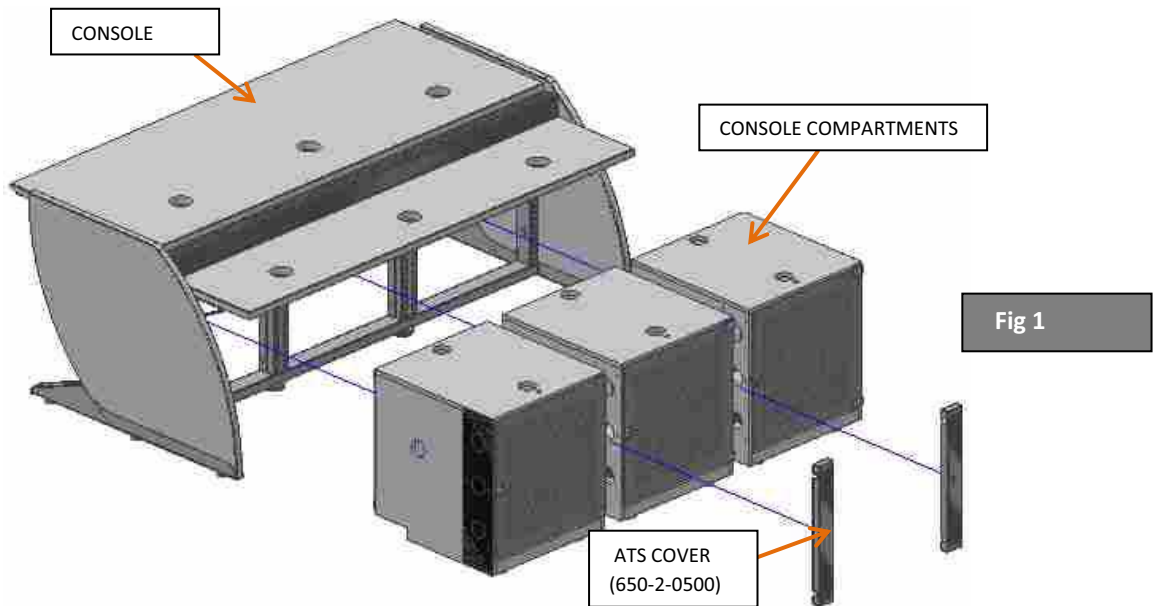

Fig 8

ATS Assembly Instructions



Assembly process

Graphic assembly process



To mount an **ATS cover**, you need at least two **compartments** running.

STEP 1 – Mount the **console compartments** at the back of the **console** (Fig.2).
See **console compartment** assembly chapter (25).

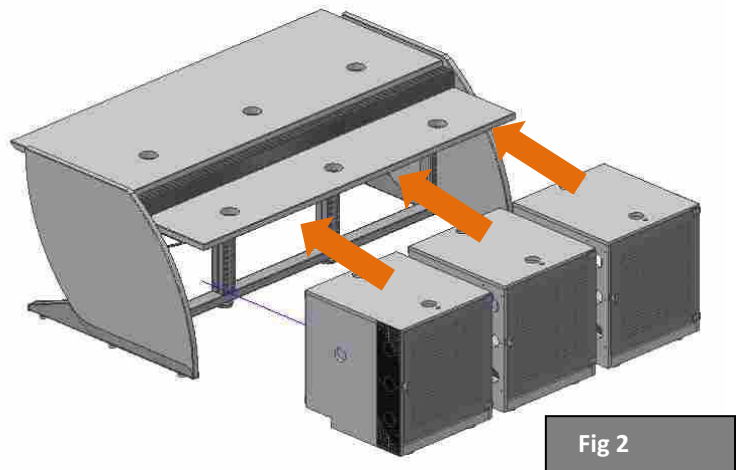

Fig 4

STEP 2 – Mount the fastening for the **ATS cover**.

On the inside of the **ATS**, mount the **4 M6 joining caps** at the ends of the **compartments** at the back and on the inside **4 M6x16 ISO7380 Allen screws** (Fig. 3 and 4).



Leave some play in the **caps**; do not tighten them fully (Fig.5).

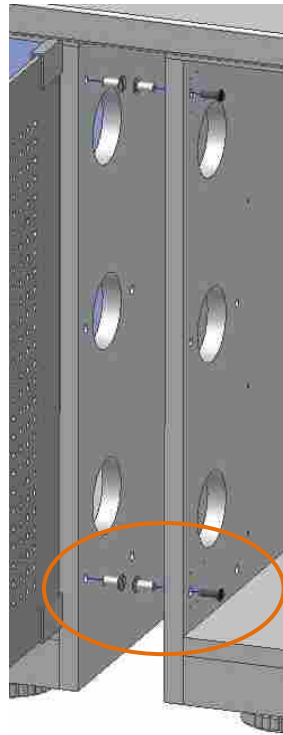

Fig 3



Fig 5

STEP 3 – Fit the **ATS cover** on the internal **joining caps** of the **ATS**. Make a reverse “L” movement (Fig. 6 and 7).

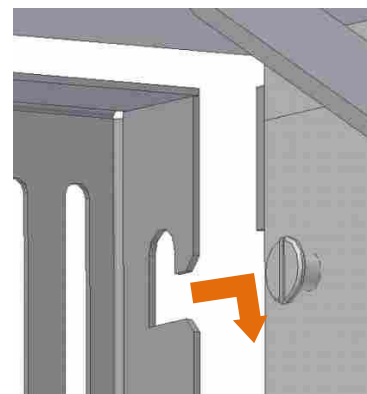
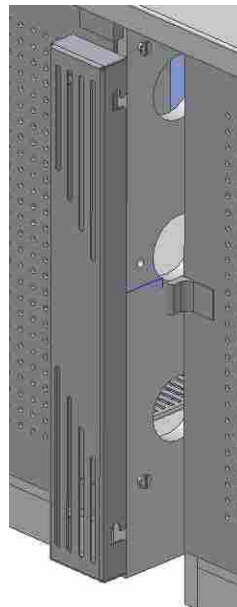



Fig 6

ATS ACCESSORIES:

8 SOCKET BASE (570-2-0008 / 9008) Join with the 19" accessories of the base to the inside of the **ATS** using the two caps of the **compartment + 2 M6 DIN7985 Phillips screws** (Fig.9).

 Mount the **8 socket bases** to the **compartments** before inserting them in the **consoles** (Fig. 8).

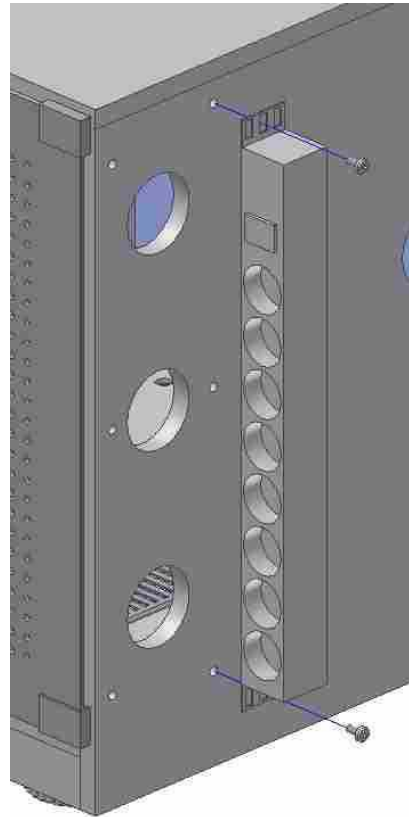

Fig 8

TECNO LAN[®]



 **Gesab**[®]
guarantee for the future

www.gesabgroup.com
info@gesabgroup.com

www.gesab.es
info@gesab.es

Barcelona: 902 113 186

Madrid: 902 113 187

Internacional:
+34 93 842 70 50

+34 91 534 50 54