

*scanmagnetics.fi*

ONE

# ENO

**scanmagnetics**

## GESAB

Un equipo comprometido, con espíritu de superación. Un grupo de profesionales dispuestos a enlazar el conocimiento con la experiencia y la innovación para ser garantía de futuro.

A committed team, with a spirit of self-improvement. A group of professionals eager to link knowledge with experience and innovation to be guarantee for the future.

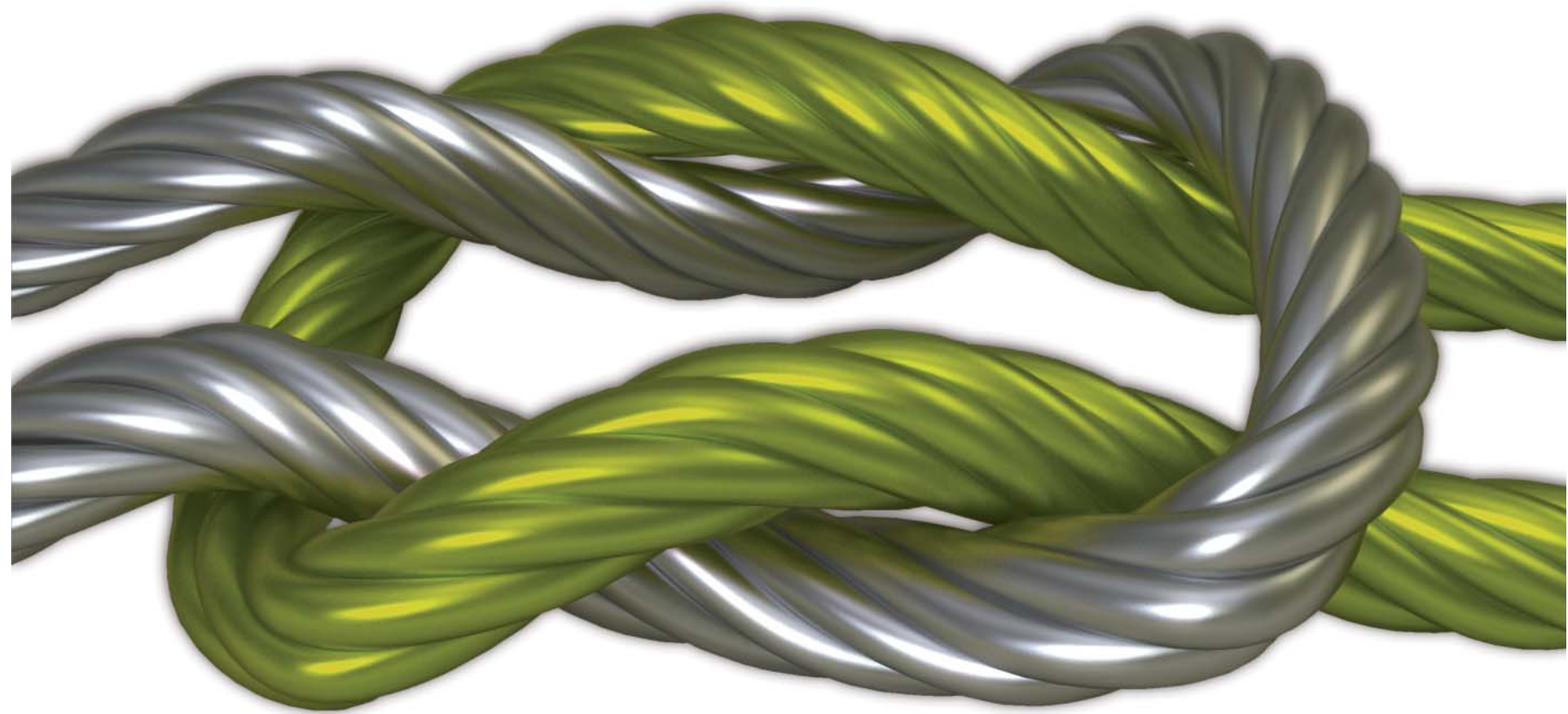

# ONE

Nuevas ideas, nuevos pensamientos. El primer contacto visual, las primeras sensaciones. El inicio de una estética, de una filosofía. El compromiso y el respeto por el entorno.

Le invitamos a experimentar el concepto ONE.

New ideas, new thoughts. The first visual contact, the first sensations. The beginning of an aesthetic, a philosophy. The commitment and respect for the environment.

We invite you to experience the ONE concept.







Antonio Arceiz  
DIRECTOR DEL AREA DE SALAS DE CONTROL Y DECISIÓN  
CONTROL & DECISION CENTER MANAGER

Avanzar y anticipar, una premisa en la estrategia corporativa para un sector en constante evolución.

Make progress and anticipate a premise in the corporate strategy for a sector in constant evolution.

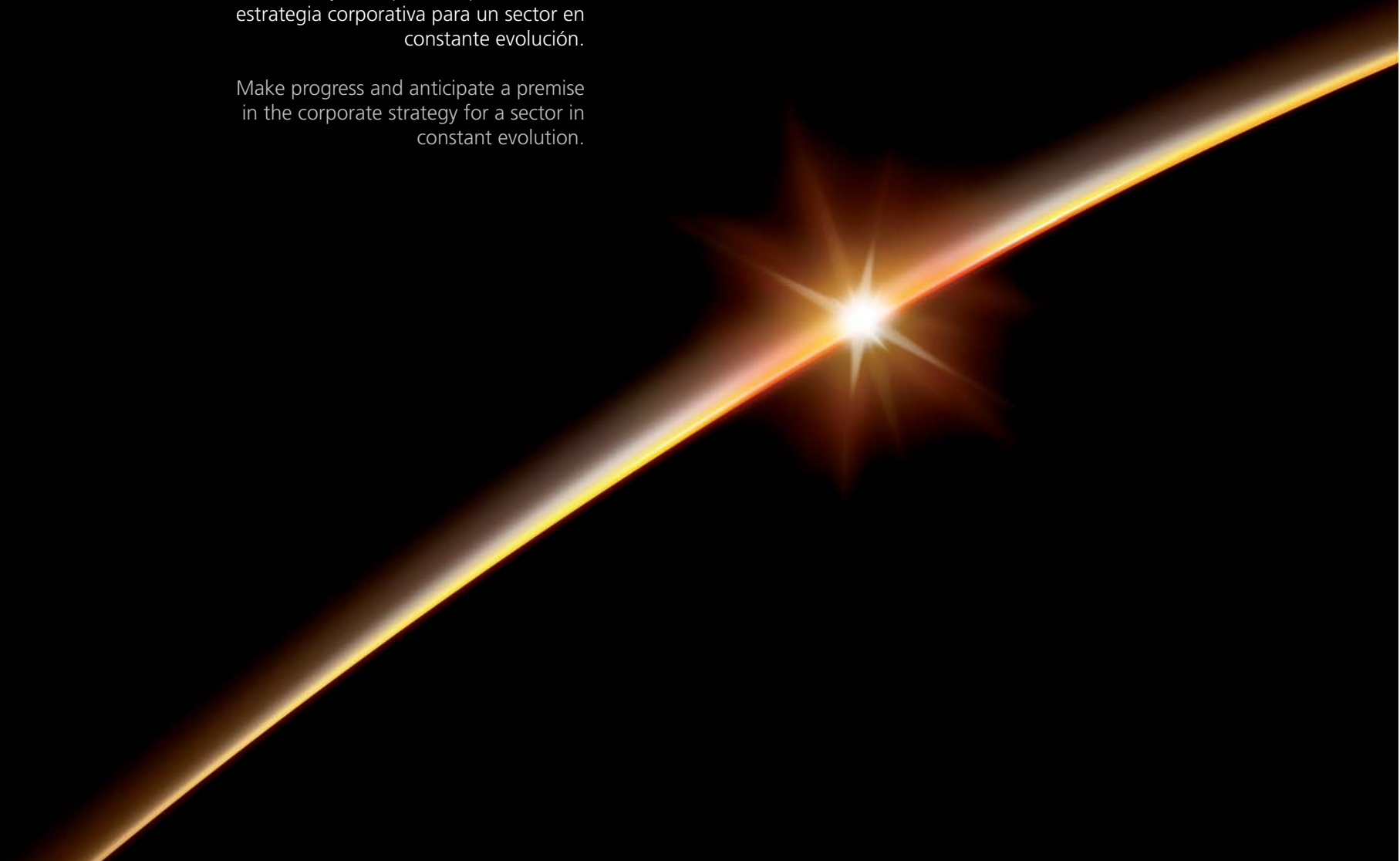







Santiago Tomás  
DIRECTOR DE INNOVACIÓN  
INNOVATION MANAGER



Innovación es el reto diario y constante de todo un equipo que trabaja para alcanzar el equilibrio perfecto entre funcionalidad y estética.

Innovation is the constant daily challenge of a whole team, working to achieve the perfect balance between functionality and aesthetics.



# security

Conceptos globales que en ONE son esenciales: transmitir seguridad de arriba a abajo, de dentro a fuera; resaltarla, destacarla; es nuestra obligación, nuestra convicción.

Global Concepts that in ONE are crucial: providing security from top to bottom, from inside to outside, to enhance and stand out; it is our duty, our conviction.





Marià Vilaró  
DISEÑADOR  
DESIGNER



Conceptualización y diseño orientados  
hacia una meta: perdurar en el tiempo.

Conceptualization and design oriented  
toward one goal: to endure over time.







ONE

## space

Espacios generosos para grandes necesidades, sin límites, sin fronteras, con capacidad, con versatilidad. Organizar y ordenar un entorno tecnológico, transformable y adaptable.

Generous spaces for large requirements, no limits, no boundaries, able, with versatility. Organize and manage a technological environment, transformable and adaptable.

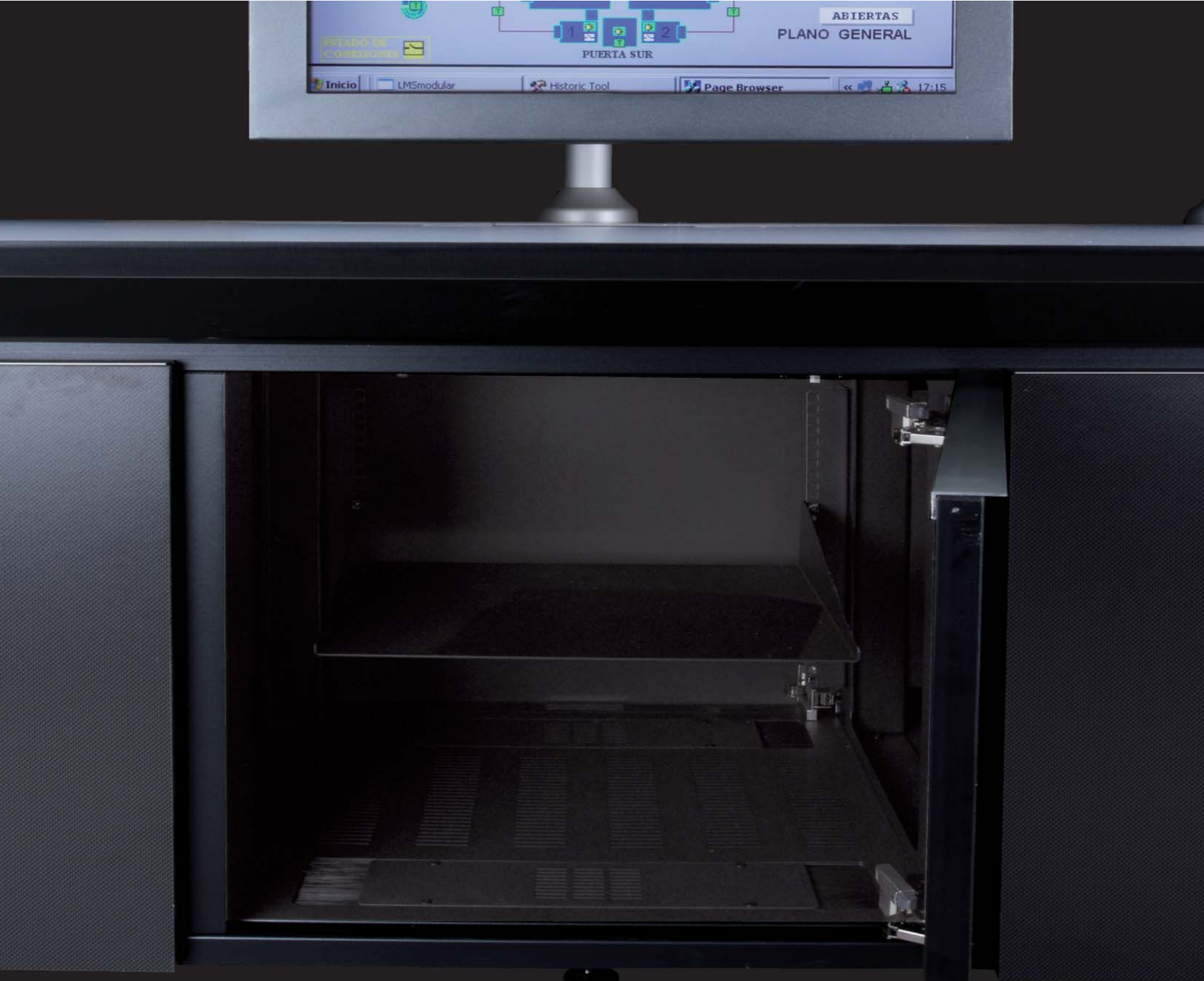

David Costa  
INGENIERO DE PRODUCTO  
PRODUCT ENGINEER



Cada proyecto es un reto de ingeniería.  
Investigar, desarrollar e innovar para alcanzar  
los objetivos marcados.

Each project is an engineering challenge.  
Research, develop and innovate to achieve the  
objectives.





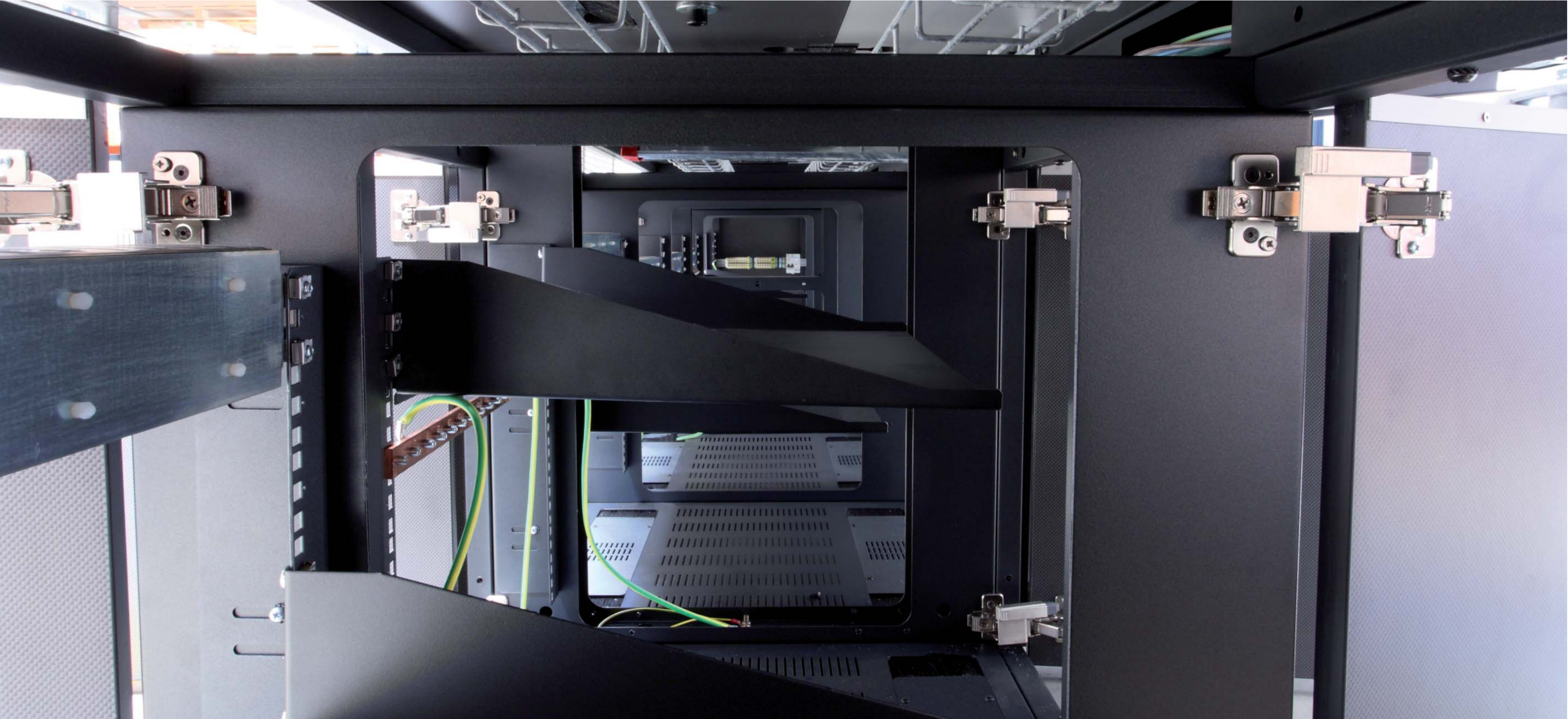









Joan Moreno  
DIRECTOR DE OPERACIONES  
OPERATIONAL AREA MANAGER

Disponer de uno de los centros de producción más modernos, nos permite hacer realidad los sueños e ilusiones de un gran equipo.

Having one of the most modern production facilities, allows us to realize the dreams and illusions of a great team.



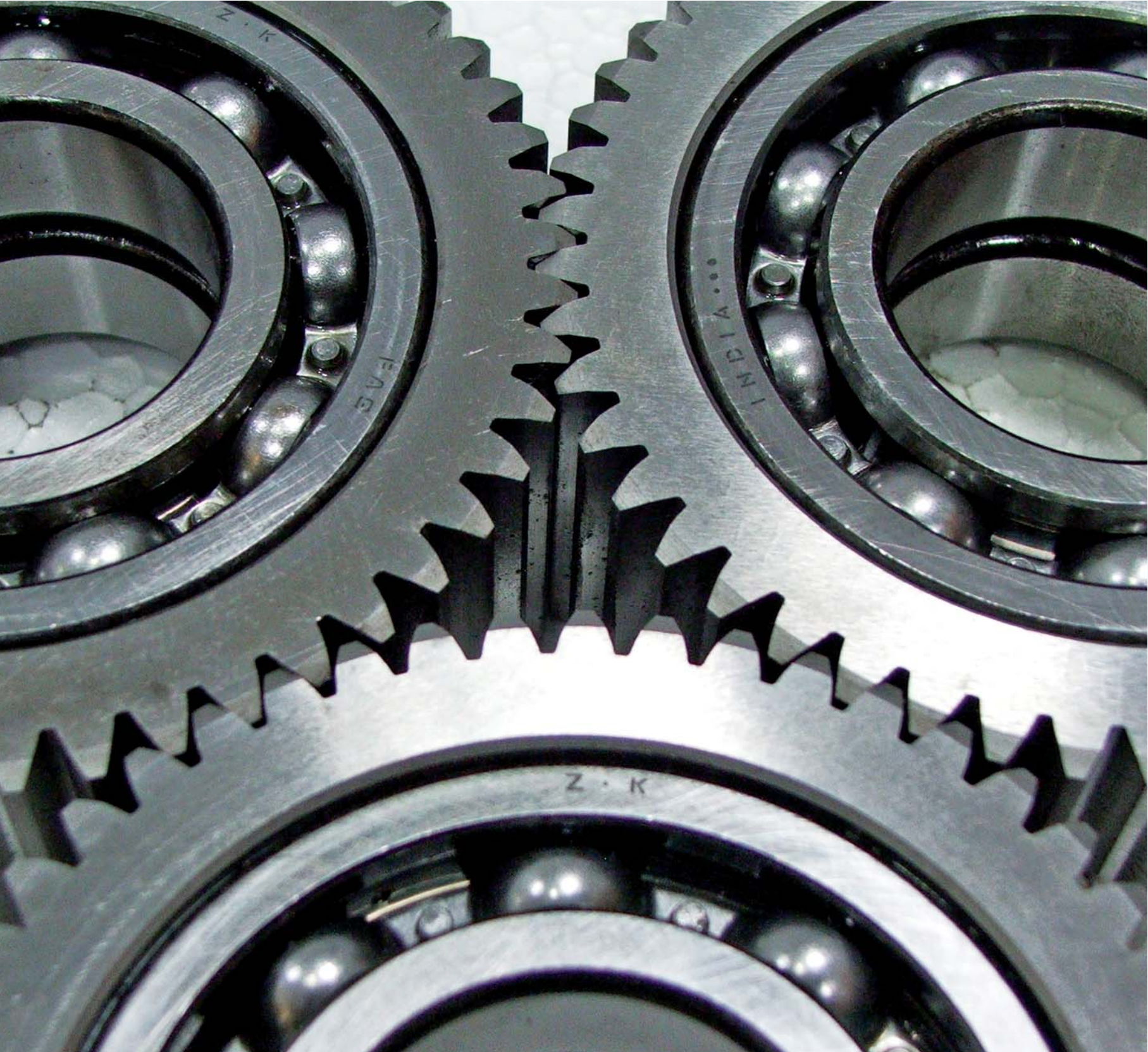

# connectivity

Experiencia y conocimiento puestos a disposición de ONE para disfrutar sin limitaciones, sin condiciones.

Conectar, modificar, ampliar. En definitiva: gestionar con las máximas garantías.

Experience and knowledge are available to ONE to enjoy without limitations, without conditions.

Connect, modify, add. In short: to manage with maximum guarantees.





# [Plug in]

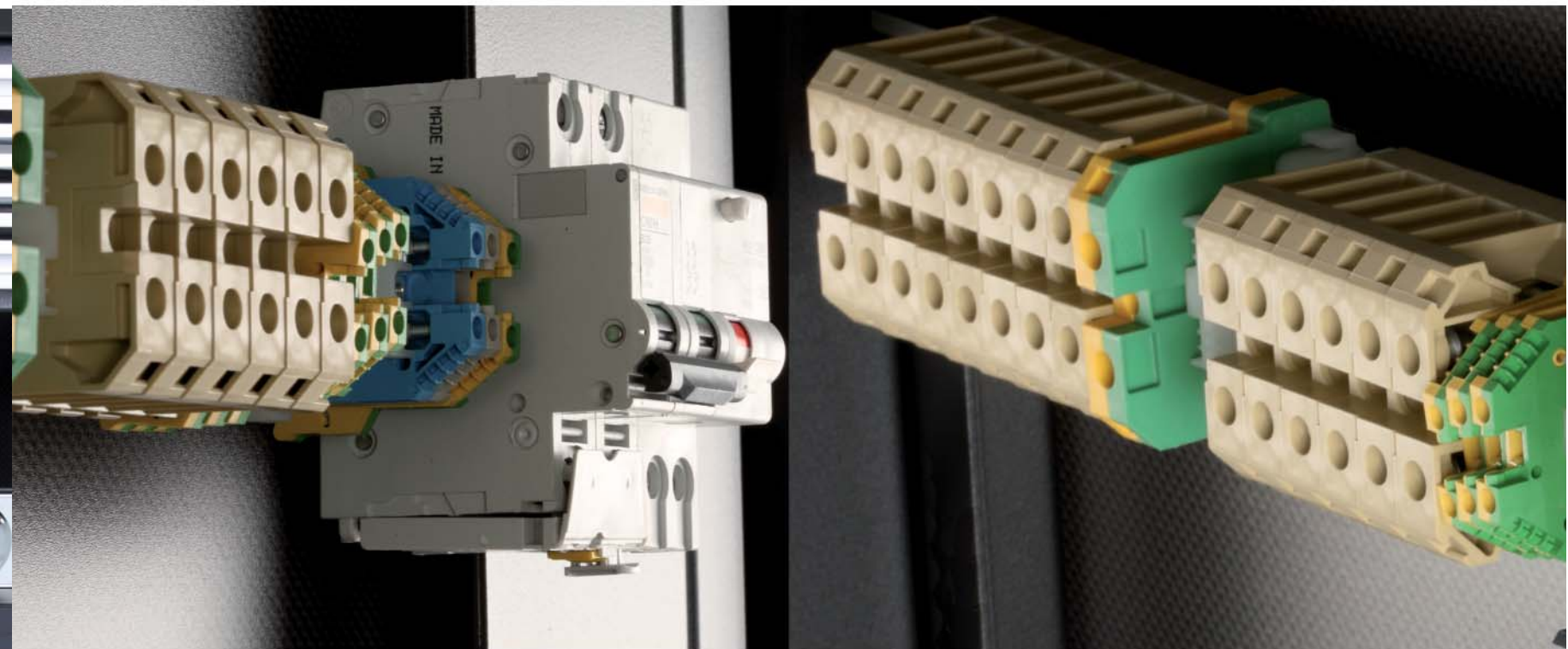
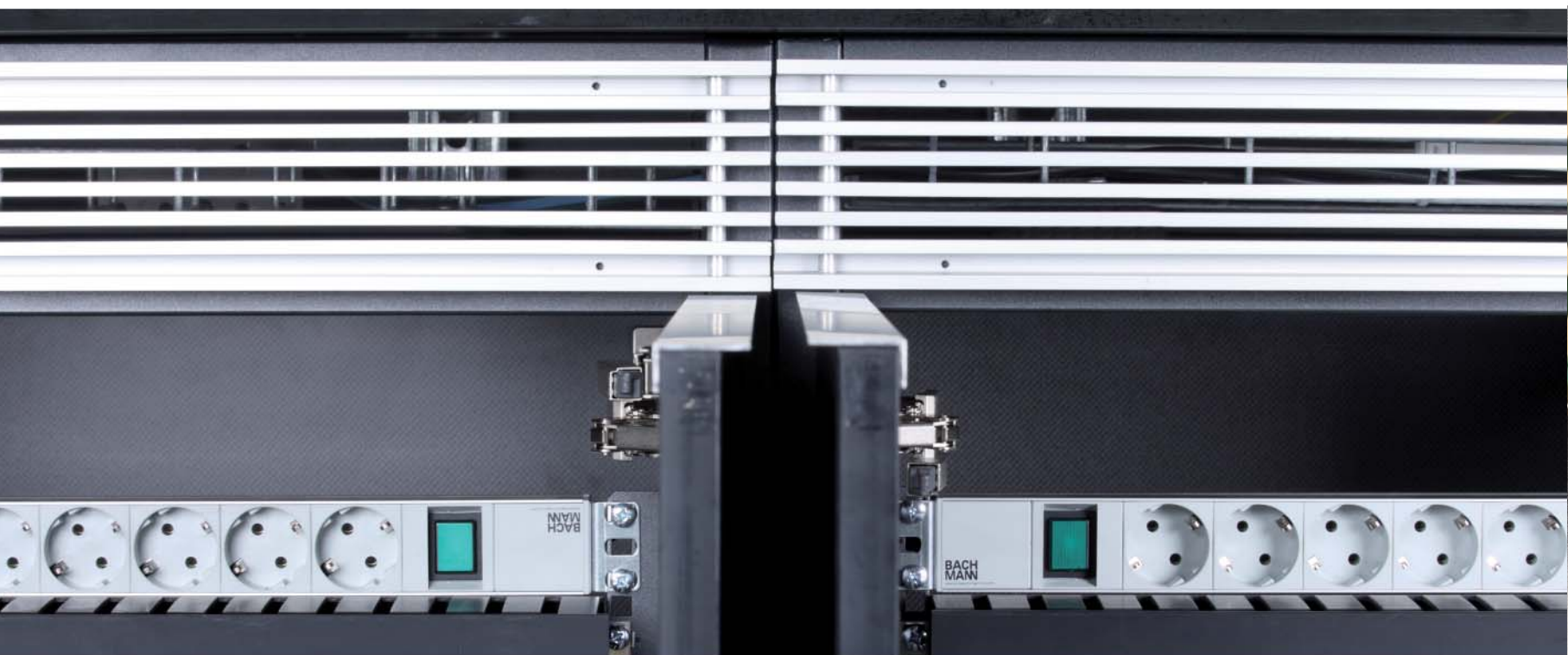

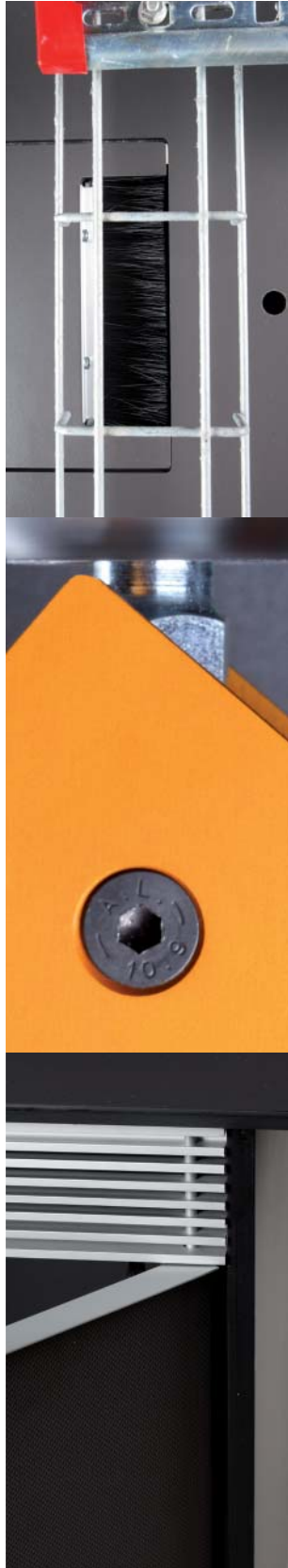

# precision

Cada detalle cuenta, por pequeño que sea, por insignificante que parezca.

La armonía entre los elementos genera la potencia necesaria para que las cosas funcionen. Y funcionen bien.

Every detail counts, however small, however insignificant it may seem.

The harmony between the elements generates the power needed to make things work. And do it well.







# flexibility

Una serie viva, en constante progreso, exigente, expectante, receptora de sus necesidades, de lo que precisa y demanda.

An alive series, in constant progress, demanding, expectant, receptive to needs, of what is necessary and requested.



# versatility

Encontrar una sola palabra que defina ONE es tarea ardua y compleja. A partir de este momento esperamos que el adjetivo lo proponga usted.

Find a word that defines ONE is an arduous and complex task. From this moment we are expecting for you to propose an adjective.

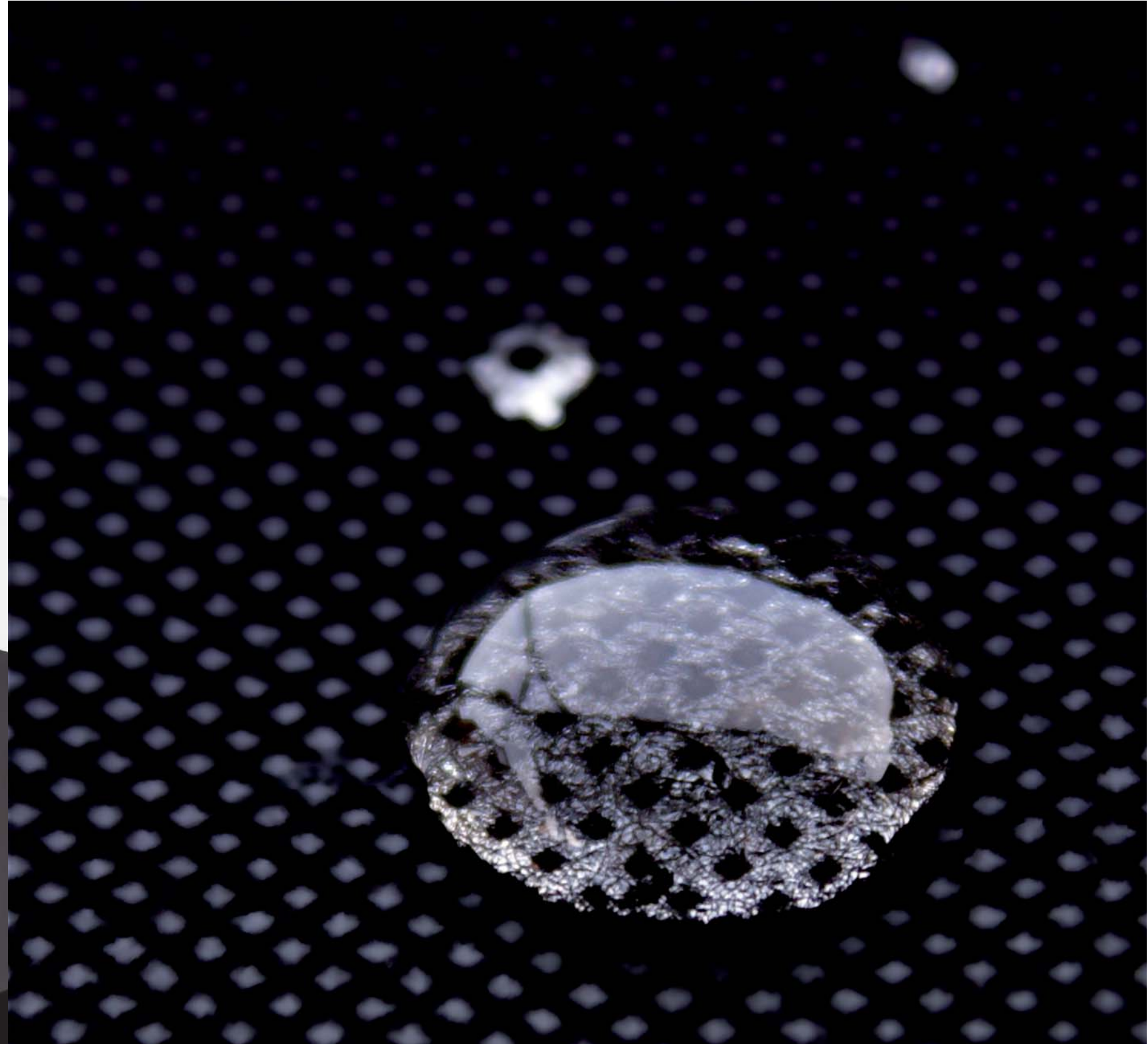



# Especificaciones técnicas

- 1 Área de Operación – Alcance dinámico, ergonómico y confortable.  
Operation Area - Dynamic scope, ergonomic and comfortable.
- 2 Conexiones Personales - Integración de conexiones específicas para los operadores  
Personal Technical Area - Integration of specific connections for operators

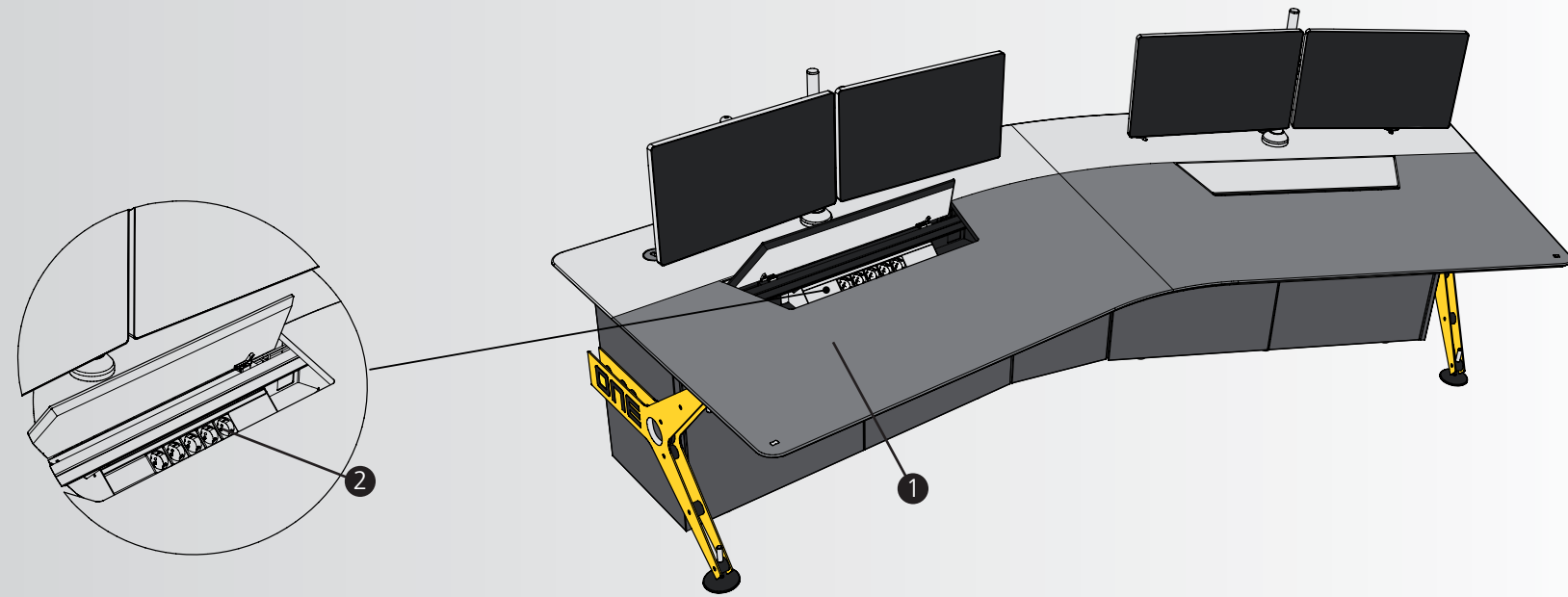

# Technical specifications

- 3 Área Técnica de Servicio - Garantiza la gestión integral del cableado y conexionado  
Technical Service Area - Guarantees the integrated management of cables and connections
- 4 Compartimento técnico – Máxima capacidad, adaptabilidad y flexibilidad.  
Technical compartments - Maximum capacity, adaptability and flexibility.
- 5 Pasacables - Accesos y enlaces al Área Técnica de Servicio.  
Cable ducts - Access and links to the Technical Service Area.

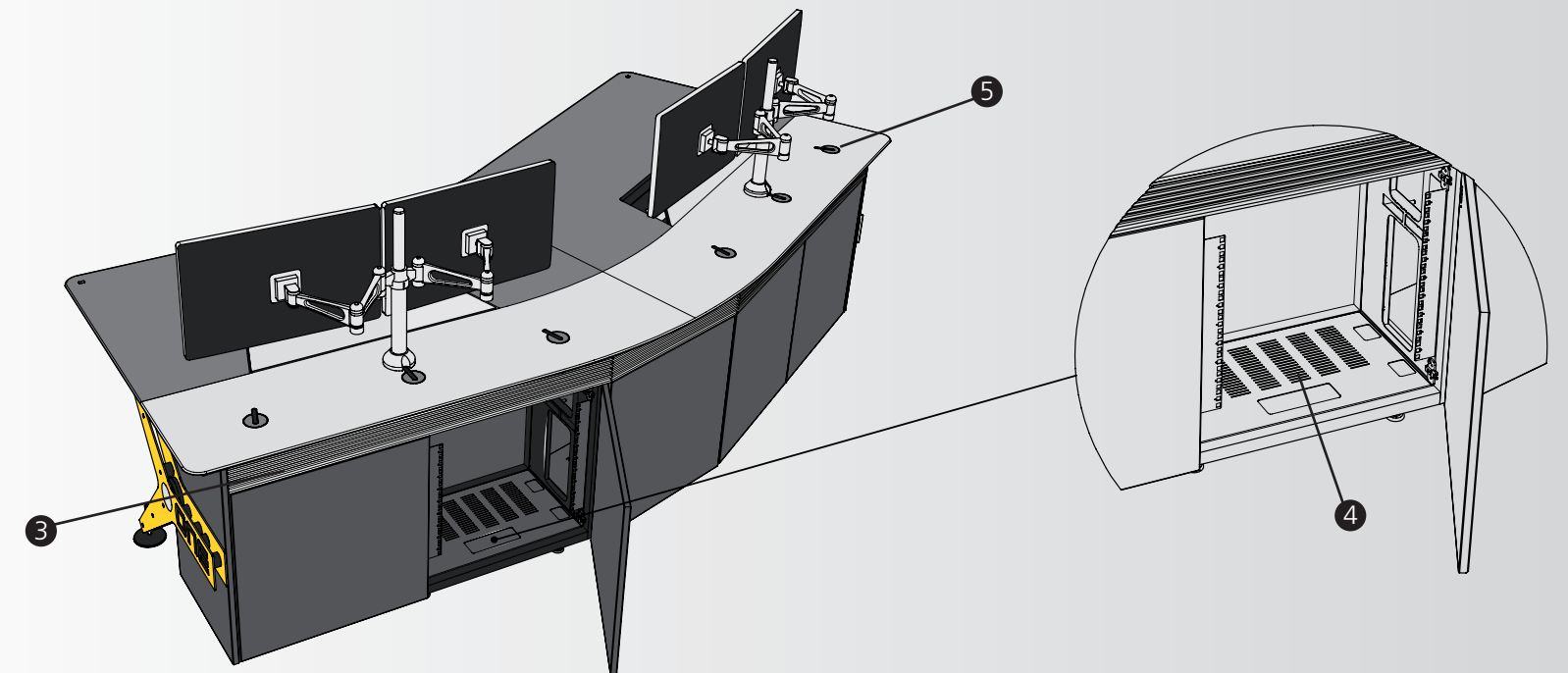



space GESAB

***scanmagnetics***