

Jacarta

PRODUCT CATALOGUE



2012

(1.0)

scanmagnetics.fi

Contents

Environmental Monitoring

| | |
|-----------------------|----|
| interSeptor | 3 |
| interSeptor Pro | 5 |
| Alert Centre | 9 |
| ZonePod v2 | 10 |

Power & Environmental Monitoring

| | |
|--------------------------|----|
| interSeptor iMeter | 12 |
| iMS Software | 16 |
| PowerFox8 | 18 |

Sensors

| | |
|---------------------------------|----|
| Go-Probe | 20 |
| intelliAmp Current Sensor | 21 |

IP Cameras

| | |
|----------------------------|----|
| J-CAM Indoor Camera | 22 |
| J-CAM Outdoor Camera | 24 |

interSeptor

Environmental Monitoring System for Data Centres, IT Rooms and Racks

Effective monitoring of IT environments is critical to any successful business continuity strategy. interSeptor provides a sophisticated, yet cost-effective method of remotely monitoring temperature, humidity and a whole variety of status conditions including water leaks, smoke, UPS, generators, voltage and security.



Key Features

- **Remote temperature/humidity monitoring across Ethernet network**
- **Provision to connect 2 x Go-Probe interSeptor sensors (water, smoke, security, etc.)**
- **Capacity to connect an additional temperature/humidity sensor and 2 further Go-Probe sensors**
- **10/100Mbps auto-sensing**
- **Monitoring via web browser or SNMP network management system**
- **Email alarm notification with optional SMS, voice alarm messaging (using Jakarta Alert Centre facility)**
- **Alarm schedule facility to enable alerts to be sent only when required**
- **Extensive on-board data logging and graphing.**

interSeptor is a 10/100 Ethernet device that can be monitored via the network. High and low critical/warning thresholds can be set to ensure early notification of air conditioning failure and other potentially disastrous environmental problems.

interSeptor is the key to providing early warning of potentially catastrophic conditions that may be developing in critical environments. Configuration can be quickly carried out via Telnet, serial connection or browser interface, and monitoring handled via the browser or a network management system.

Uniquely, interSeptor's optional Go-Probe sensors can be attached to the remote temperature/humidity sensor to minimise cabling runs and installation time.

Extra facilities such as SNMP, DHCP and daily status reporting, make the interSeptor just about the most complete remote environmental monitoring product of its kind worldwide.

Email Alerts

interSeptor can be configured to email up to 12 recipients in the event of an alarm condition. It is possible to configure this facility so that different recipients receive different types of alarm messages if required (e.g. informational, warning, etc.). It is even possible to send interSeptor current status reports to email recipients on a daily basis.

Java Viewer

interSeptor's Java viewer provides an effective visual monitor, accessible via the browser interface. Real-time information can be viewed in graph or meter mode.

Logging/Graphing

The capacity to extensively log environmental information and events via interSeptor ensures that ongoing problematic conditions can be analysed in detail and remedial action taken. This facility can even help to identify heating and cooling inefficiencies and reduce costs. All interSeptor log information can be imported into popular spreadsheet programs such as Excel.

Further information can be quickly viewed and analysed using interSeptor's real time and historical graphing facilities.

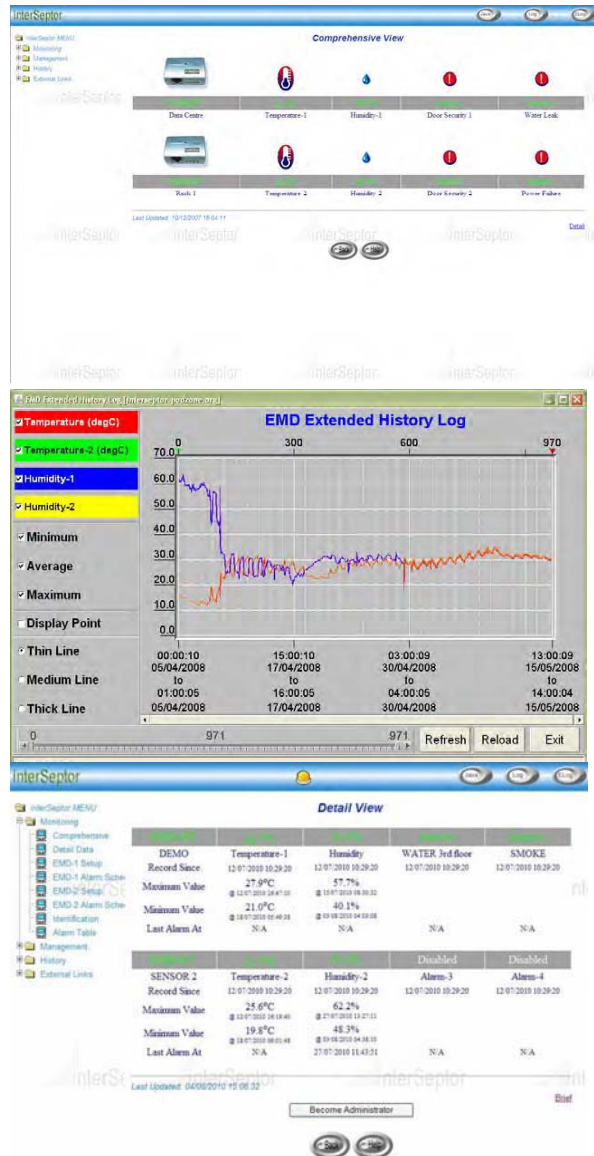

interSeptor—Specifications

- Network: 10/100Mbps Ethernet (auto-sense)
- Sensors: Temperature/Humidity plus 2 Go-Probe sensors
- Optional Equipment: 1 x Temperature/Humidity sensor plus up to 4 x Go-Probe sensors
- Configuration: Telnet, browser, Serial
- Monitoring: Browser, NMS (up to 8 workstations)
- Dimensions (cm): 2.6 (h) x 13.1 (w) x 8.7 (d)
- Weight: 110
- Power: 12VDC
- LED: Power, Status, 10/100 link
- Firmware Upgrade: Via Network or Serial Connection
- System Security: IP-based filtering and password protection
- Alert Configuration:
 - Temperature/humidity: High/low warning and critical thresholds—user configurable.
 - Go-Probe Sensors: Normally open/closed or high/low active—user configurable.
- Logging: Historical event and status logs
- Log Interval: User configurable
- Graphs: Real-time and historical
- Go-Probe Sensors:
 - Water leak with 3-18m sensor Cable
 - Security Contact (door open)
 - Power Fail
 - Smoke
 - Universal Dry Contact sensor (normally open/closed or high/low)
- Warranty: 2 Years

interSeptor Pro

Environmental Monitoring and Alert System for Data Centres and Racks

Feature Overview

- Supports up to 24 temperature/ humidity Sensors
- Supports up to 48 Additional Environmental Alarm Sensors
- Voice, SMS, Email and SNMP Alerts
- Web Browser Interface



Key Features

- 3 versions: 8-port, 16-port, 24-port
- Remote temperature/ humidity monitoring across Ethernet network (all temperature/ humidity sensors supplied)
- Provision to connect up to 48 optional Go-Probe sensors (water, smoke, security, power, etc.)
- Monitoring via web browser, Telnet and SNMP network management system
- Email and SNMP Alerts
- SMS Alerts via optional GSM Modem
- Automated voice and SMS alerts with escalation procedure and alarm acknowledgement via Jakarta Alert Centre (optional)
- Alarm Schedule facility to enable alerts to be sent only when required
- Extensive on-board data logging and graphing
- Relay outputs for automated crisis management
- 8-port interSeptor Pro can also be supplied with 2, 4 or 6 temperature/ humidity probes

Preventing Data Centre Disaster

Crucial to any business continuity strategy is the implementation of an effective monitoring and alerting system. Air-conditioning failure, water ingress, fire, power failures and physical security breaches are just a few of the many potential problems that seriously threaten the integrity of network hardware and data.

In situations where rooms are unmanned for any length of time, especially at weekends and overnight, these problems can, if left unattended, result in significant network downtime and cost.

interSeptor Pro provides an advanced, yet uncomplicated solution to Data Centre room/ rack monitoring and early-warning alarm notification. Environmental conditions can be monitored and logged, alarm thresholds configured, and automated early-warning alerts delivered to key IT personnel via telephone voice messages, SMS, email, web browser and SNMP traps. An Alarm Beacon/ Sounder option is also available for on-site visual and audible alerts if required.

Flexibility, Scalability for Maximum Return on Investment

interSeptor Pro is available in 3 models, equipped with 8, 16 or 24 environmental ports. Each interSeptor Pro environmental port can monitor a temperature/ humidity probe, and from that probe a further 2 alarm sensors can be monitored. The design of the interSeptor Pro therefore provides superb scalability and flexibility, with the 24-port unit being able to monitor up to 24 temperature/ humidity sensors and up to 48 alarm sensors.

Advanced Features to Meet Changing Data Centre Requirements

In keeping with other Jakarta products, interSeptor Pro is easy to install and remarkably easy-to-use. The device can be monitored using a web browser, Telnet or Network Management System using SNMP.

interSeptor Pro's powerful feature-set also allows for control of rack doors and other on-site facilities remotely or via an optional USB keypad.

Automatic switching/control of associated local devices during crisis conditions is also possible, as is extensive logging of data centre conditions for pro-active analysis and fault-finding.

interSeptor Pro uses Cat5 cable to connect between its RJ45 environmental ports and temperature/humidity probes. This makes it extremely easy to locate all sensors where needed and re-locate if necessary as required.



Configuration

IP configuration can initially be carried out via the front panel LCD using the menu buttons. Full configuration of temperature and humidity high/low threshold settings, polling and logging options, alerting options, etc. can then be carried out quickly and easily via a web browser.

Monitoring

Monitoring of the interSeptor Pro can be carried out over the internet using a web browser or via a Network Management system using SNMP.

Alerts

Email and SNMP alerts can be triggered to provide early warning of environmental conditions. In addition, voice alerts to mobile/landline telephones, and SMS alerts can be activated in conjunction with the Jakarta automated Alert Centre facility. The Alert Centre service can provide alarm notifications to up to 6 personnel in an escalation sequence to ensure alerts can be managed efficiently. Alternatively, SMS messages can be transmitted via an optional GSM modem.

Logging

interSeptor Pro has extensive on-board logging capabilities to ensure alarm conditions can be tracked, early identification of potential problems carried out and trend analysis conducted as required. Log files can be delivered to key personnel daily in .csv format or downloaded as required.

Graphing

interSeptor Pro's onboard Java graphing feature enables log files to be analysed instantly via a web browser for trend analysis and problem solving.

Installation

interSeptor Pro has been designed for ease of installation and use. Multiple temperature/humidity sensors are provided out-of-the-box to ensure individual rack and room monitoring can begin immediately. Customers can choose to implement their own Cat5 (straight-through) cabling between the sensors and the interSeptor Pro's RJ45 ports or alternatively purchase one of the optional Sensor Cabling packs.

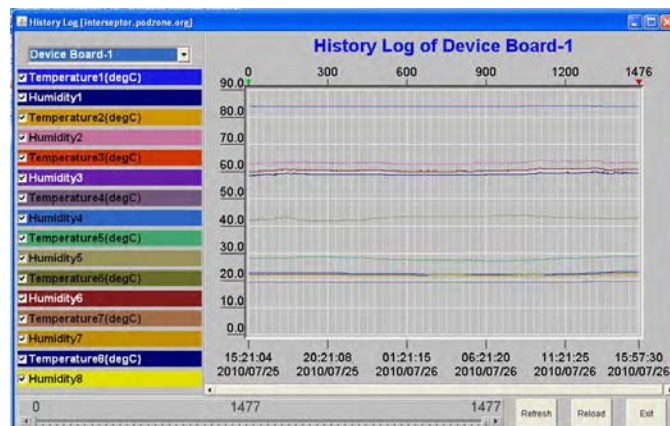

interSeptor Pro - Sensors

Jakarta Temperature and Humidity Sensor

Each interSeptor is supplied with the required number of temperature/humidity sensors for the version purchased. i.e. 8, 16 or 24. Two optional Go-Probe sensors can also be connected to each temperature/humidity probe from the range of sensors detailed below. High/low warning and critical alarm thresholds can be easily configured via the interSeptor Pro's web browser interface.



Jakarta Water Detector

The Jakarta interSeptor Pro water detector uses an advanced leak detection cable to sense the presence of water along its length. The water detector can be supplied with either 3 or 18m of sensor cable and 4m of interface cable.



Jakarta Security Sensor

The Jakarta interSeptor Pro Security Sensor is a magnetic reed switch that can be used to detect the opening of doors, racks, windows and cupboards.



Jakarta Smoke Detector

The Jakarta interSeptor Pro Smoke Detector is a mains powered, ionisation based smoke detection unit that can be positioned to monitor for early signs of fire, providing both an interSeptor alarm and an audible alarm upon detection. This sensor is provided with either a 4 or 18m interface cable.



Jakarta Voltage Sensor

The Jakarta interSeptor Pro Voltage Sensor can be used to monitor spare power outlets for outages and interruptions. As soon as power to the outlet is lost the interSeptor will provide an alarm. This sensor is provided with either a 4 or 18m interface cable.



Alternative cable lengths are available with all Jakarta Go-Probe sensors if required.

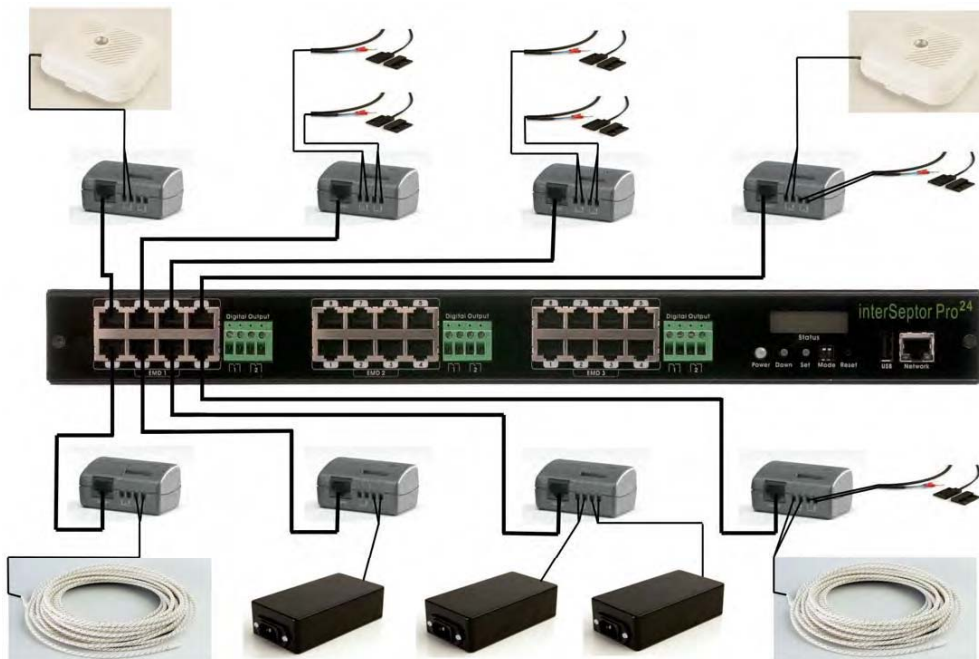

interSeptor Pro with 8 temperature/humidity sensors, plus water leak, smoke, power and security sensors attached

Alert Centre

Using an environmental monitoring system is a step forward in terms of providing useful information about in-room and in-rack conditions. But critical to the value of the system is its ability to deliver early-warning alerts, and in particular voice alerts, to key personnel 24/7.

The Jakarta Alert Centre works in conjunction with the interSeptor Pro to provide Voice and SMS alerts to up to 6 personnel.

Key Features

- Voice, SMS & Emails delivered to up to 6 personnel
- Escalation procedure to assist alarm management
- Online access/management of personnel contact details, etc.
- Online event log history - track an alert from start to finish (e.g. who responded to an alarm and when)
- Annual subscription free for first year with interSeptor Pro (UK only)

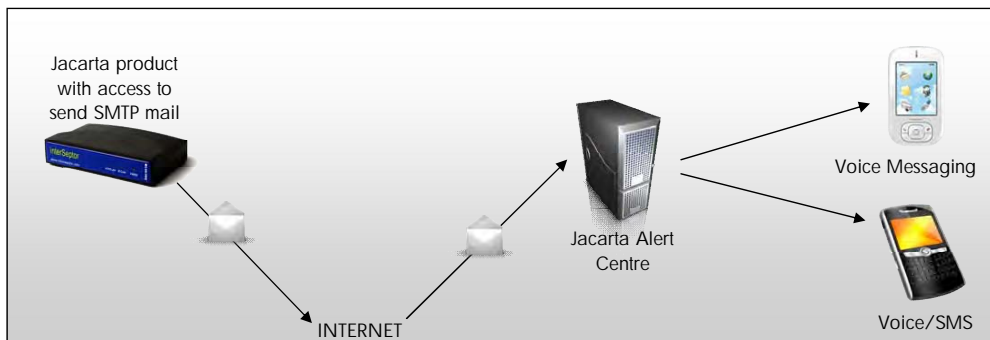

Additional Optional Equipment for interSeptor Pro

- Dry Contact/Universal interface cables for connection to onsite facilities (eg. air conditioning, UPS, alarm panel etc.)
- Alarm Beacon/Sounder for local audible/visual alerts
- USB keypad for manual operation of relay outputs (for access control, etc.)
- interSeptor Pro Cable Pack including various lengths of Cat5 cable to connect between the interSeptor Pro and the temperature/humidity sensors
- GSM Modem for SMS Alerts

Customer Service

Technical support is available for the interSeptor Pro directly from a member of the Jakarta Technical department via email and telephone, free-of-charge. We aim to respond as quickly and efficiently as possible with minimum customer inconvenience.

Warranty

interSeptor Pro is supplied with a 2-year swap-out warranty in the unlikely event of a problem.

interSeptor Pro—Specifications

| | 8-Port | 16-Port | 24-Port |
|--------------------------|--|---------|---------|
| • Sensors:Temp/humidity: | 8 | 16 | 24 |
| • Go-Probe Sensor Ports: | 16 | 32 | 48 |
| • Relay Outputs: | 2 | 4 | 6 |
| • Optional equipment: | | | |
| • Go-Probe Sensors | 16 (max) | 32(max) | 48(max) |
| • Weight (kg): | 3.4 | 3.5 | 3.6 |
| • Network: | 10/100Mbps Ethernet (auto-sense) | | |
| • Configuration: | Telnet, browser, LCD | | |
| • Monitoring: | Browser, NMS, Telnet | | |
| • Dimensions (cm): | 4.4 (h) x 43.5 (w) x 27.1 (d) | | |
| • Power: | 100 - 240VAC 50/60Hz | | |
| • Status Indicators: | Status LCD, Power LED, 10/100 LED | | |
| • Firmware Upgrade: | Via network connection | | |
| • System Security: | IP based filtering and password protection | | |

- Alerts:
 - Email (12 recipients)
 - SNMP traps (8 Receivers)
 - Voice/SMS via Alert Centre (optional)
 - SMS via GSM modem (optional)
- Alert Configuration:
 - 1.Temperatue/Humidity:
 - High/Low warning and critical thresholds
 - 2.Go-Probe Sensors:
 - Normally open/closed or high/low active
- Logging:
 - Historical event and status logs
- Log Interval:
 - User-Configurable
- Graphs:
 - Real-time and historical
- Go-Probe Sensors:
 - Water Leak with 3-18m of sensor cable
 - Security Contact (Door Open)
 - Smoke
 - Power Fail
 - Universal Dry Contact sensor (normally open/closed or high/low)

Alert Centre

Telephone Voice and SMS Messaging System

The Jakarta Alert Centre service works in conjunction with our interSeptor, interSeptor Pro and SP8 environmental monitoring products to provide automated SMS and voice message alerts to mobile and landline phones.

The Alert Centre service is a cost-effective way of knowing exactly what is happening in your IT or Comms room 24/7.

The service is supplied on an annual subscription basis. Alarm conditions from Jakarta monitoring devices can be relayed via emails to the Alert Centre servers which will then automatically invoke the alert notification escalation procedure (see right). On receipt of an email alarm from the interSeptor, interSeptor Pro or SP8, an initial call will be made from the Alert Centre server to the main customer site relaying a voice message detailing that an alarm condition has occurred.

A voice message call will then be made and an SMS sent to the first named contact detailing the nature of the alarm. If the first recipient does not acknowledge the alarm, the voice and SMS message will be sent to the second and third recipients and so on. Emails will also be sent to all 6 recipients.

Alert Centre Escalation Procedure

The Jakarta Alert Centre sends messages to your proprietary 'Contacts' as follows:

Immediately:

The installed location is telephoned



After 30 seconds:

'Contact 1' is notified by telephone, text and email



(If no response from Contact 1)

After 2 minutes:

'Contact 2' is notified by telephone, text and email



(If no response from Contact 2)

After a further 2 minutes:

'Contact 3' is notified by telephone, text and email

.....and so on up to 6 contacts

Jakarta can accept no liability for any interruption that may be caused at any time in the Alert Centre service.
All specifications subject to change without notice.

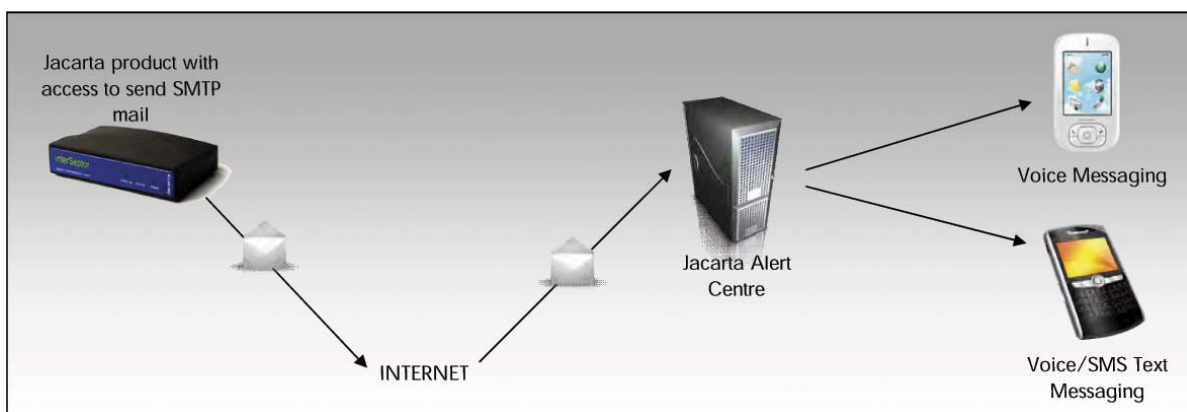

The Alert Centre is user manageable via login facilities at www.jakarta.com and www.interseptor.com. Personnel contact information can be updated anytime as required.

The Alert Centre Service is available in the following countries:

Australia, Belgium, Canada, Cyprus, Dubai, France, Germany, India, Netherlands, Norway, Republic of Ireland, Spain, Sweden, Switzerland, United Kingdom and USA. (All messages are delivered in English)

On purchasing an Alert Centre subscription, you will be sent the Alert Centre registration documents and user guide. One Alert Centre subscription is required for each device that you wish to register.

ZonePod GSM

Environmental Alarm System For Data Centres, Offices & Industry

The Jakarta ZonePod GSM is a compact, cost-effective and easy-to-install environmental monitoring alarm system. Designed for use in IT rooms and data centres as well as retail, office and industrial environments, ZonePod GSM will silently keep watch over your critical locations and provide you with early warning of potential environmental threats.

The versatility of the ZonePod GSM means that it can be effectively used in a wide range of environments. Sensors can be connected in any combination for maximum flexibility. This makes it a perfect solution for both small and large organisations alike.

Typical Applications:

-Temperature monitoring in computer rooms to provide early warning of air conditioning failure.

-Smoke monitoring in all kinds of environments where 24 hour notification is required.

-Leak detection for data centres where an overnight leak could have a catastrophic effect.

-Gathering information about duration and time of power failures in locations where standby power for ZonePod GSM is available.

-Humidity monitoring where condensation can seriously effect the operation of electronic equipment.



Key Features

- Monitors up to 6 environmental sensors in any combination
- Wide range of sensors including temperature, humidity, smoke, water leak, power, security, air conditioning, fire panel, etc.
- Voice messages or SMS text alerts can be sent to up to 10 recipients when an alarm occurs
- 6 types of alarm message can detail site location and specific alarm information (user configurable)
- Integrated LCD display shows sensor types connected and status
- 'Alarm' and 'Normal' status LEDs for each sensor
- Password protection for alert facility
- Alarm restored messages to notify that conditions have returned to normal
- Automatic daily line status reporting
- High/low user configurable warning thresholds for temperature and humidity
- Easy to use on-board menu facility to disable voice and text alerts when required
- Different alarm types may be sent to different personnel
- Alarm event history log
- Landline connection for fail-safe alerting

ZonePod GSM can accommodate an extensive range of sensor options to fulfil a whole host of monitoring requirements. Apart from setting high and low alarm thresholds for temperature and humidity sensors, no additional sensor configuration is required.

The sensors are supplied with an interface cable of 0.2m or 5m and additional extension cable lengths are also available.

SMS and/or voice message alerts can be sent to up to 10 recipients when the ZonePod GSM alarms occur to ensure remedial action can be taken at the earliest opportunity.

ZonePod GSM can be installed and configured in minutes:

- Step 1:** Insert SIM card (not supplied)
- Step 2:** Connect sensors to ZonePod
- Step 3:** Configure required thresholds for temperature and humidity sensors (if used)
- Step 4:** Record alarm messages and input required detail for text messages
- Step 5:** Input required telephone numbers

The ZonePod is also available as a landline only model if required.



| | Temperature | Humidity | Water | Smoke | Power | Security | Universal |
|--------------|---|--|---|--|---|---|---|
| | | | | | | | |
| Cable Length | Part Number | Part Number | Part Number | Part Number | Part Number | Part Number | Part Number |
| 0.2m | ZPTS1 | ZPHS1 | N/A | N/A | N/A | N/A | N/A |
| 5m | ZPTS5 | ZPHS5 | ZP3WD5 | ZPSD5 | ZPVS | ZPSS5 | ZPDC5 |
| Description | High/Low thresholds can be configured on the ZonePod for temperature alerts | High/Low thresholds can be configured on the ZonePod for humidity alerts | Water detector is supplied with a 3m sensor cable. Other lengths available on request | The ZonePod smoke detector utilises an ionisation detection system to detect smoke | ZonePod sensors can be connected to 13 amp supplies to monitor for power failings | The security sensor with magnetic reed switch can be used to detect unauthorised access | Universal ZonePod sensor can be used to monitor any normally open/closed output |

If longer cables are required, extension cables can be provided in the following lengths.

| Cable Length | 7m | 15m |
|--------------|--------|---------|
| Part Number | ZPEXT7 | ZPEXT15 |

ZonePod GSM—Specifications

- Available Sensors:
 - Temperature
 - Humidity
 - Smoke
 - Water Leak Detection
 - Power
 - Security
 - Universal
- Optional Equipment:
 - Battery backup unit (UPS)
 - SNMP / Web adaptor for alarm status monitoring
 - Alarm Beacon / Sounder
- Thresholds:
 - High/Low thresholds configurable on temperature and humidity sensors
 - Open/Closed configuration option for all other sensors (auto-setup for sensors other than universal sensor)
- GSM Modem:
 - Dual Band
- Configuration:
 - Direct configuration via 5 button key pad and screen
- Monitoring:
 - On screen monitoring (either through sensor type or sensor reading, user configurable)
- Alerts:
 - Via voice or SMS messaging.
 - Programmable Alarm messages along with a common site message.
- Dimensions (cm):
 - 28.5 (h) x 21.0 (w) x 4.9 (d)
- Weight:
 - 2.62kg
- Power:
 - 12VDC, adapter included
- Warranty:
 - 1 Year

interSeptor iMeter

POWER & ENVIRONMENTAL MONITORING SOLUTION For Data Centres, Server Rooms and Racks

interSeptor iMeter is an advanced environmental and power monitoring solution that has been designed to help provide IT personnel with answers to the following 10 questions:

- How can I reduce power usage in my data centre?
- Which racks in my data centre are using the most power and are the most expensive to run?
- Can I reduce the power consumption in my data centre racks?
- Can I assess whether it is more economical to invest in newer, less power-hungry IT equipment rather than continuing to run my existing equipment?
- Can temperature in the data centre be safely increased to help reduce air conditioning and air handling costs?
- Can I build up a clear picture of power usage over time that will enable me to reduce my Amps per U-space Ratio and running costs?
- What effect does running rack fans have on the AU ratio?
- Can I reduce power usage without affecting network operations?
- Is it possible to be notified immediately about significant changes in the data centre power and environmental conditions that may otherwise have serious repercussions for network availability?
- Can I implement a solution to all the above questions without disruption to my existing network infrastructure and without downtime?

The interSeptor iMeter solution



3 principal components make up the interSeptor iMeter solution:

1. Jacarta Go-Probe Power and Environmental Sensors
2. iMeter Master device with 8 sensor ports
3. iMeter Slave device with 8 sensor ports

Go-Probe Power and Environmental Sensors

The Jacarta range of Go-Probe sensors can be connected to each iMeter Master or iMeter Slave device in any combination to provide full flexibility for your power and environmental monitoring solution. Go-Probe Sensors include:

- IntelliAmp Current Sensor (Amps)
- IntelliAmp Voltage Sensor (Volts)
- Temperature/Humidity
- Airflow Sensor
- Water Leak Detector
- Smoke Detector
- Security Sensor (door open)
- Motion Sensor (PIR)

iMeter Master

The iMeter Master module is a 1U rackmountable Ethernet device with remote monitoring capability via its web browser interface, SNMP, Modbus and RS485. The device is equipped with 8 sensor ports and 4 expansion ports for connection of iMeter Slave devices. Multiple Jacarta Go-Probe sensors can be monitored from a single IP address in conjunction with iMeter Slave modules.

iMeter Slave

Each iMeter Slave supports up to 8 Go-Probe Power and Environmental Sensors and is equipped with daisy chain in and out ports for connection to the iMeter Master and/or other iMeter Slave devices. Up to 18 Slave modules can be connected to each iMeter Master expansion Port (72 Slave modules are supported by the iMeter Master in total).

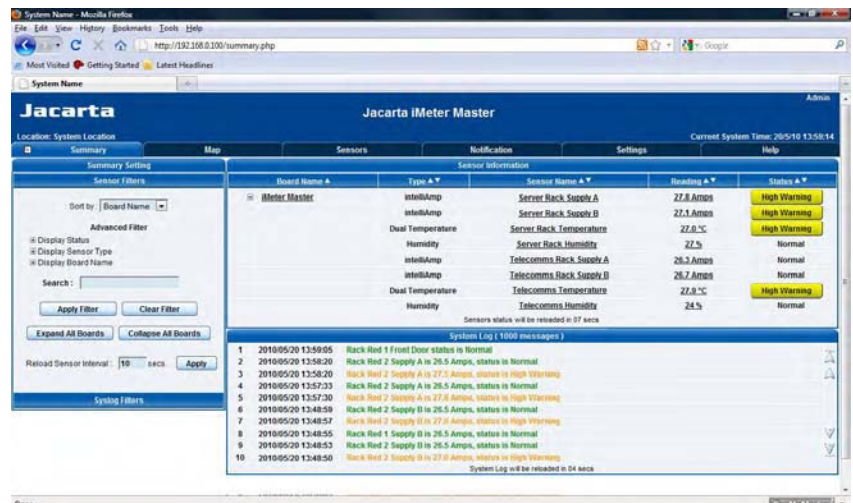

POWER MONITORING

The power of the iMeter solution lies in its range of intelligent sensors. The sensors can be connected and monitored in any combination, and can be installed without network downtime.

intelliAmp Current Sensor

The remarkable intelliAmp Current Sensor has been designed to monitor the current draw of racks via 16A and 32A cables. The sensor contains a unique calibration mechanism to enable it to be positioned at the point where the optimal current reading can be obtained. The fact that the sensor simply clips to the cable means no network downtime is required to start monitoring your racks.



The intelliAmp Sensor can be used to track power usage within racks over time to ensure consumption can be gradually reduced as equipment is upgraded. The sensor can allow users to make power usage comparisons between racks and identify the most and least expensive racks to run. By building up a picture of power consumption across the data centre down to rack level, IT personnel can start to effectively manage power usage going forward and make savings where possible.

The flexibility of the intelliAmp Sensor means it can also be used to identify the effect on power consumption of running fans in racks, for instance, or the power implications of running the data centre at a higher temperature. This may help to reduce air conditioning power consumption but may also result in internal fans working harder and an increased power usage in this area. The key point is that the intelliAmp will help you to understand what is happening with the power across your data centre and manage it more efficiently.



intelliVolt Voltage Sensor



The intelliVolt voltage sensor simply connects into one of the iMeter sensor ports and plugs into a mains outlet. Voltage is monitored between 0 and 265v. High and Low threshold settings can be user configured on the iMeter to ensure alarm notification during over or under voltage conditions.

ENVIRONMENTAL MONITORING

A variety of environmental sensors are available with the iMeter to ensure your data centre or racks are constantly monitored for potentially catastrophic events. Alerts can be delivered rapidly to IT and Facilities personnel via email, SNMP or SMS to ensure remedial action can be taken quickly.

The Jakarta Go-Probe sensors can be connected to the iMeter Master and Slave modules in any combination. Sensors can be auto-detected by the iMeter to simplify installation and configuration.

The following diagram highlights the potential sensor capacity and flexibility of the iMeter.

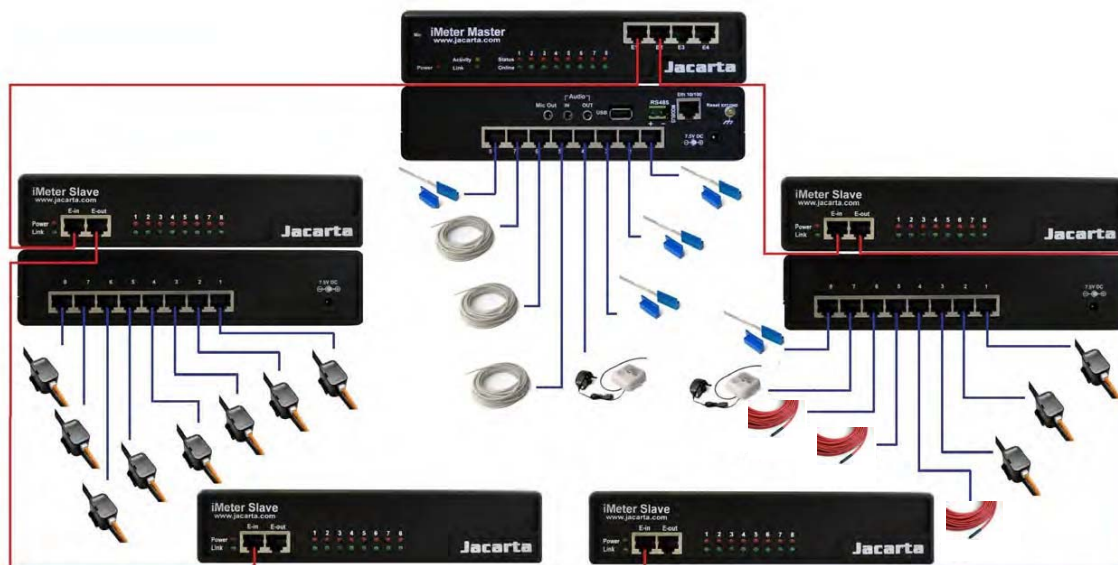

iMeter Master—Specifications

- Sensors: 8x RJ45 Auto detecting ports.
- Relay Outputs: Any RJ45 sensor port can be configured as a relay
- Optional Equipment: iMeter Slave: 8x RJ45 sensor ports
iMeter DC16: 16x Dry contact 2-wire ports
GSM Modem
- Network: 10/100Mbps Ethernet (auto-sense)
- Status Indicators: Sensor online and status LED, Power LED, 10/100 LED
- Configuration: Browser, Modbus
- Monitoring: Browser, NMS
- Weight (kg): 1.09
- Dimensions (cm): 4.6 (h) x 21.6 (w) x 13.8 (d)
- Power: 7.5VDC PSU supplied
- Alerts: Email, SNMP traps, Voice and SMS via optional additional GSM USB Modem
- Alert Configuration: 1.Temperature/Humidity: High/low warning and critical thresholds (user configurable)
2.Go-Probe Sensors: Normally open/closed or high/low active (user configurable)
3. intelliAmp/intelliVolt: High/low warning and critical thresholds (user configurable)
- Logging: Event, Status and configuration
- Graphs: Real-time and historical
- Graphs Interval: Daily, Weekly, Monthly and Yearly
- Firmware Upgrade: Via Network Connection
- System Security: IP based filtering and password protection
- Warranty: 1 Year

iMeter Slave—Specifications

- Sensors: 8x RJ45 Auto detecting ports.
- Relay Outputs: Any RJ45 sensor port can be configured as a relay
- Optional Equipment: iMeter Slave: 8x RJ45 sensor ports
iMeter DC16: 16x Dry contact 2-wire ports
- Link Distance: Up to 300m
- Configuration: Via iMeter Master
- Monitoring: Via iMeter Master
- Dimensions (cm): 4.6 (h) x 21.6 (w) x 13.8 (d)
- Weight (kg): 1.09
- Power: 7.5VDC PSU supplied
- Status Indicators: Sensor online and status LED, Power LED, Link LED
- Warranty: 1 Year

iMS

Power Management Software for the Data Centre

The iMeter Management Software (iMS) is an extremely powerful data collection, analytical and reporting software suite that enables IT and Facilities personnel to manage data centre power usage more efficiently. Power and environmental data can be viewed and analysed in meaningful and intuitive formats so that decisions aimed at reducing power costs and improving operational efficiency can be made.

Effective power management can only be carried out by monitoring power consumption down to rack level. However, the task of being able to collate, manipulate and effectively analyse the huge amounts of data generated by monitoring to rack level is colossal. iMS will enable you to quickly and easily identify which racks use the most power, understand more readily why your power usage 'is what it is', and where power savings can potentially be made. Consumption can then be tracked over time to ensure that data centre power costs are minimised as far as possible.



iMS Overview

iMS is comprised of two principal components:

- iCollect is the data collection engine that runs continually to log all the data from the power and environmental sensors connected to the iMeter.
- iReport is the reporting and analytical component. This provides users with the ability to manipulate the collected data in a whole host of formats (by sensor, by time period, etc.) to facilitate further analysis.



Key Features

- iMS monitors the Jakarta iMeter and its attached sensors to collect all required sensor data – power (current, voltage), temperature, humidity
- Power usage, temperature, etc. can be monitored down to rack level
- Analysis can be carried out on specific sensors or groups of sensors and over user defined time periods
- Data can be analysed by data collection interval: Hour, day, week, month, quarter or year
- Minimum, maximum and average readings can be produced for analysis
- Carbon footprint and kWh data can be reported and graphed to provide an indication of power consumption and costs
- Reports can be formalised in pdf, html and Excel formats
- Data can be viewed in an extensive variety of chart formats (bar graph, line graph, etc.)

Power Analysis

Data centre power analysis can be carried out down to rack level using a variety of iMS options:

Power Grid presents a chronological view of the data gathered from the intelliAmp and intelliVolt power sensors by iCollect. Similar grids are available for temperature and humidity values.

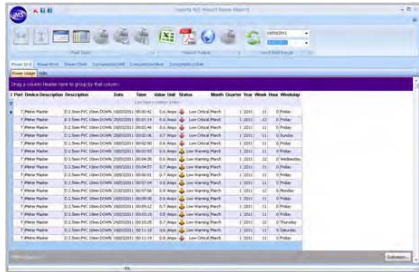

Power Pivot enables you to manipulate the data into whatever time period for whatever sensors (of the same type) you require. Minimum and maximum values can be viewed as well as averages for specific time periods.

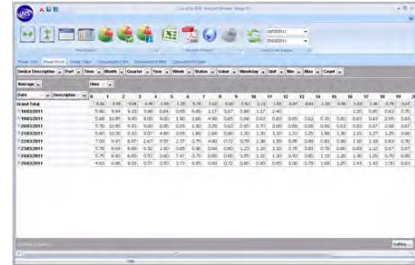

Power Chart facilitates a graphical representation of your required data in Bar, Area, Column, Line or Pie chart form.



Consumption Chart facilitates presentation of the power consumption data in your required chart format.

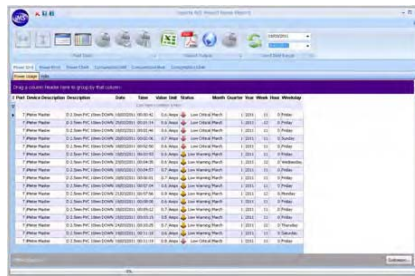

Consumption Grid provides detail for analysis relating to minimum, maximum and average power usage over time. In addition, indicative kW average, Daily kWh, cost per kWh, and Carbon Footprint information is also available.

| Date | Min | Max | Average | Daily kWh | Cost per kWh | Carbon Footprint | |
|------------|--------|-----|---------|-----------|--------------|------------------|---------|
| 2010/01/01 | 1.1075 | 0.5 | 1.11 | 0.076 | 21.045 | 1.894 | 11.4142 |
| 2010/01/02 | 1.1911 | 0.5 | 1.1 | 0.076 | 18.281 | 1.496 | 8.88 |
| 2010/01/03 | 2.4021 | 0.5 | 1.11 | 0.088 | 14.937 | 1.224 | 7.946 |
| 2010/01/04 | 2.074 | 0.5 | 0.94 | 0.049 | 15.497 | 1.399 | 8.435 |
| 2010/01/05 | 2.2099 | 0.5 | 1.11 | 0.096 | 13.011 | 1.071 | 7.262 |
| 2010/01/06 | 2.2792 | 0.5 | 1.11 | 0.098 | 13.049 | 1.087 | 7.409 |
| 2010/01/07 | 1.1947 | 0.5 | 1.1 | 0.089 | 11.594 | 1.026 | 6.394 |
| 2010/01/08 | 1.201 | 0.5 | 1.1 | 0.098 | 11.262 | 1.084 | 7.207 |

Consumption Pivot enables you to generate reports for specific sensors, time periods, and for any parameters available in the Consumption Grid.

| Time | Min | Max | Average | Daily kWh | Cost per kWh | Carbon Footprint | |
|------------|--------|-----|---------|-----------|--------------|------------------|---------|
| 2010/01/01 | 1.1075 | 0.5 | 1.11 | 0.076 | 21.045 | 1.894 | 11.4142 |
| 2010/01/02 | 1.1911 | 0.5 | 1.1 | 0.076 | 18.281 | 1.496 | 8.88 |
| 2010/01/03 | 2.4021 | 0.5 | 1.11 | 0.088 | 14.937 | 1.224 | 7.946 |
| 2010/01/04 | 2.074 | 0.5 | 0.94 | 0.049 | 15.497 | 1.399 | 8.435 |
| 2010/01/05 | 2.2099 | 0.5 | 1.11 | 0.096 | 13.011 | 1.071 | 7.262 |
| 2010/01/06 | 2.2792 | 0.5 | 1.11 | 0.098 | 13.049 | 1.087 | 7.409 |
| 2010/01/07 | 1.1947 | 0.5 | 1.1 | 0.089 | 11.594 | 1.026 | 6.394 |
| 2010/01/08 | 1.201 | 0.5 | 1.1 | 0.098 | 11.262 | 1.084 | 7.207 |

Report Output allows data from your Power Pivot to be converted into Excel, PDF and HTML formats. Charts can be saved as a bitmap image.

iMS Installation Requirements

| Minimum Requirements | Recommended Requirements |
|-------------------------------|--------------------------|
| Quad Core Processor | Xeon Quad Core Processor |
| 4GB RAM | 32GB RAM |
| Windows 7 Professional 64-bit | Windows Server 64-bit |
| Disk Space: 15GB + | Disk Space: 250GB + |

PowerFox8

Power and Environmental Monitoring System for Data Centres & Racks

The Jakarta PowerFox8 is a powerful, intelligent power management device for monitoring and controlling power in IT environments. PowerFox8 can monitor and log the input current, voltage and frequency as well as the current being supplied to the devices connected to each of the 8 receptacles on the rear of the unit. It is possible to remotely control the power to the connected devices either via a schedule, a timed delay or immediately.



This functionality makes the PowerFox8 a vital tool in controlling IT power costs, minimising engineering site visits to reset remote equipment, and assessing future power requirements.

In addition, the PowerFox 8 can be used to monitor critical data centre and rack environmental conditions such as temperature, humidity, water ingress, smoke and security.

The PowerFox8 is supplied with a temperature/humidity probe and door security sensor as standard and an additional optional sensor can be connected if required. Email alerts and SNMP traps will provide early-warning of an environmental or power problem.



Key Features

- Monitor and log input voltage current, voltage and frequency
- Monitor and log output current to connected devices
- Monitor and log temperature/humidity and alarm sensor events (water, smoke, etc.)
- Connect devices up to a maximum load of 15 Amps via 8 output receptacles
- Front panel LED for real-time status conditions and when thresholds are exceeded.
- Activate extended devices via digital outputs
- Control the PowerFox8 power outlets remotely through console or network
- Crisis event management—turn on/off devices or activate digital outputs based on alarm events, e.g.. Turn off devices when critical over-temperature threshold is exceeded
- Comprehensive power management and flexible configuration through web browser, NMS, Telnet, SNMP, or HyperTerminal (console)
- Configurable user security control
- User-friendly interface to display input and output status
- Detailed data-logging for statistical analysis and diagnosis
- Upgrade utility for easy firmware upgrade
- Event notification through SNMP traps or email alerts
- Daily history reports sent automatically via email
- Supports SSL V3 and SSH V1 protocol
- Administrator and multiple user password protection for double layer security

The Power Manager

Using the PowerFox8's web interface or SNMP, it is possible to control the power on/off for any device remotely via the network.

The PowerFox8 has eight power outlets, each of which can be monitored and controlled through the console or web interfaces. It is also possible to manually use the front panel to operate the power outlets.

The PowerFox8 console port can also be used for connecting an Environmental Monitoring Device (EMD) for monitoring temperature and humidity, plus two additional environment alarms (water, smoke, security etc.).

The PowerFox8 is provided with two digital outputs which can be used for connecting status indicators or digital switches and activating automatic responses to environmental alarm events.

The Event Manager

The PowerFox8 has a number of advanced features that enable it to be used as a crisis event manager to automatically safeguard equipment in the event of a power or environmental problem. For example, it is possible to automatically turn-off the power to critical loads if a critical over temperature threshold has been breached to prevent hardware from damage.

Also, if an input voltage problem to the PowerFox8 is detected (e.g. Thresholds can be set for conditions such as input over-voltage, under-voltage), once again, power to critical equipment can be removed automatically.

It is also possible for the PowerFox8 to automatically activate one of its digital outputs (e.g. to activate an alarm beacon or emergency fan, etc.) if necessary, when a problem is detected.

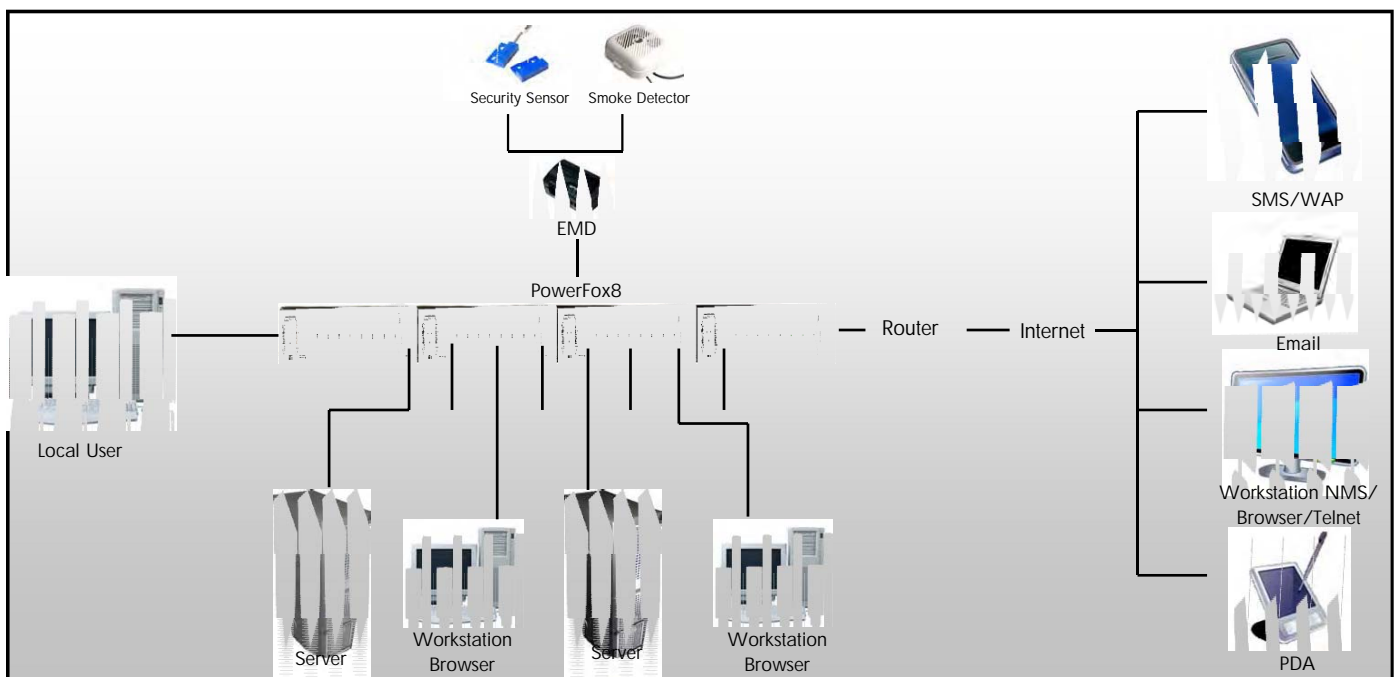

PowerFox8—Specifications

- AC Input: IEC C20 Inlet, Rating 15 Amps
Voltage: 200-250 VAC 50/60Hz
- AC Output: IEC C13 Outlet, Rating 10 Amps
Voltage: 200-250VAC 50/60Hz
Load: 10 Amps each Outlet or
15 Amps Total
- Dimensions (cm): 1U Rack: 4.4(h) x 43.6 (w) x 30 (d)
- Weight: 3.8kg
- Operating Environment: Temperature: 0°C - 40°C
Humidity: 10 - 80% non-condensed
- Warranty: 2 Years

Go-Probe Sensors

In order to provide a comprehensive Data Centre and Server Room monitoring solution it is extremely important to monitor for the presence of any potential environmental threats. Jakarta Go-Probe sensors are easy to install and configure and are compatible with all Jakarta monitoring devices.



Jakarta Water Detector

Using an advanced leak detection cable, the Water Detector can sense the presence of water along its length. The water detector can be supplied with up to 18m of leak sensing cable.



Jakarta Security Sensor

The Security Sensor is a magnetic reed switch that can be used to detect the opening of doors, racks, windows and cupboards.



Jakarta Smoke Detector

The Smoke Detector is a mains powered, ionisation based smoke detection unit that can be positioned to monitor for early signs of fire, providing both an alarm to your Jakarta device in addition to an audible alarm.



Jakarta Voltage Sensor

The Voltage Sensor can be used to monitor spare power outlets for outages and interruptions. As soon as power to the outlet is lost the sensor will trigger an alarm.



Jakarta Motion Sensor

The Motion Sensor uses Passive Infra-Red (PIR) technology to detect the presence of movement and trigger an alarm.



Jakarta Universal Dry Contact Sensor

Universal sensors can be used to monitor any normally open / closed output such as those provided by UPS, air conditioners, BMS devices, security alarm panels, generators, fire alarm panels, etc.



Jakarta Airflow Sensor

The Airflow Sensor can be used to monitor the presence of airflow coming out of air-conditioning units. If the sensor detects a loss of airflow an alarm is triggered.



Jakarta Vibration Sensor

The Vibration Sensor detects the vibrations caused during attempts to penetrate the protected rack door, wall or roof. The sensor features adjustable sensitivity to help prevent false alarms.



Jakarta Carbon Monoxide Detector

The Carbon Monoxide sensor detects the presence of dangerous Carbon Monoxide gases and provides an audible alarm in addition to triggering an alarm on your Jakarta device.

Go-Probe sensors are supplied with either 4 or 18m of interface cable to connect to your Jakarta Environmental Monitoring Device however alternative lengths are available on request (subject to maximum cable lengths).

All sensors are supplied with a 2-Year Warranty as standard.

If a sensor is required that is not listed please contact us for assistance.

intelliAmp

IT managers are now under increasing pressure to reduce the carbon footprint of their Data Centres and Server Rooms. Unfortunately the power monitoring tools currently available are not always practical to implement. Downtime typically needs to be scheduled and the failure of any of these devices can result in power loss to rack equipment.



The Jakarta intelliAmp Current Probe is a superb new alternative to inline power monitoring devices. The intelliAmp simply clips around 16Amp and 32Amp cables* to enable current draw of rack equipment to be monitored with zero downtime.

The intelliAmp's unique calibration system helps to ensure that the sensor is ideally positioned to obtain optimal readings. Once in place no further maintenance or configuration is required.

The small size of the intelliAmp ensures that it can be integrated unobtrusively into the IT environment.

Data can be collected from multiple intelliAmp sensors via a compatible monitoring device, such as interSeptor iMeter, via a Cat5E connection.

The intelliAmp's design means it does not present an additional point of failure on the network.



Key Features

- True RMS current monitoring for optimal current readings
- No downtime required for installation
- Multiple sensors can be monitored from a single monitoring device
- Small size means intelliAmp can be installed almost anywhere
- No additional network point-of-failure
- Monitors 16A and 32A Cables*



intelliAmp—Specifications

| | | | |
|------------------|-------------------------|------------------|-------------------------------------|
| Weight (g): | 80 | LED: | 10 segment LED used for calibration |
| Dimensions (mm): | 44 (w) x 60(h) x 55 (d) | Monitoring Type: | True RMS |
| Sampling rate: | 10,000 per second 50Hz | Warranty: | 1 Year |

*Cables should have 2.5mm² and 4mm² internal cable core sizes (L,N,E)

J-CAM Network Cameras

J-CAM IC Indoor Camera

The J-CAM IC is designed as a cost-effective surveillance system with progressive scan video that allows triple video streams to be simultaneously delivered in different configurations for individual recording or bandwidth and storage demands.



The camera also includes a range of features such as mechanical IR cut filter and PoE, and as such are suitable for a variety of IP video environments.



The included management software allows users to monitor up-to 16 cameras from one location, on a single screen via a simple and intuitive interface.

Key Features

- Supports H.264, MPEG-4 and MJPEG triple codec compression with multiple streams
- 1.3 Megapixel resolution
- CS mount 6mm / F1.8 megapixel fixed lens with IR cut filter correction
- Day & night function with mechanical IR cut filter
- Supports two-way audio
- Built-in SD/SDHC card slot for local storage
- Built-in 802.3 as compliant PoE
- Supports ONVIF standard to ensure interoperability



Specifications

| | | |
|---------------------------|-----------|--|
| Model Name | | J-CAM IC |
| System | | Embedded Linux, ARM-based 32-bit RISC Processor, 16mb Flash ROM 126mb DDR |
| Video Compression | | H.264, MPEG4, MJPEG |
| Video Resolution | | SXGA (1280x1024), HD720 (1280x720), VGA (640x480), QVGA (320x240), QQVGA (160x120) |
| Frame Rate | | Up to 15fps @ SXGA / Up to 30fps @ HD720, VGA, QVGA, QQVGA |
| Image Sensor | | 1/2.7" progressive scan CMOS sensor |
| Lens | | CS Mount, Fixed Iris, Focal length 6.0mm, F1.8 |
| Minimum Illumination | | 0.5 Lux / F1.8 |
| Image Settings | | ICR for day and night vision |
| | | AEC, AWB, BLC, Brightness, Contrast, Saturation, Sharpness |
| | | Flip, Mirror |
| | | OSD Timestamp & Text Caption Overlay |
| Event Management | Triggers | Motion Detection, Digital Input, Manual Trigger |
| | Actions | Digital Output, Notification via Email, FTP or SD, Snapshot |
| On-board Storage | | SD/SDHC Card Slot |
| Network | Interface | 10/100 Base-T Ethernet |
| | Protocols | IPv4, TCP/IP, HTTP, HTTPS, UPnP, RTSP/RTP/RTCP, IGMP, FTP, DHCP, DNS, DDNS, PPPoE, NTP, SMTP |
| Audio | | Built-in Mic, External Mic In, Audio Out |
| Power Supply | | DC12V/2A |
| | | AC24V |
| | | PoE 802.3af Compliant |
| Operation Temperature | | 0 ~ 40 °c |
| Operation Humidity | | 20% ~ 80% RH |
| Dimensions (L x W x H) | | 126.8mm x 72.2mm x 58.0mm |
| Weight | | 358g |
| Client System Requirement | | OS: MS Windows 7 / Vista / XP / 2k, Browser: IE 6.x or above |

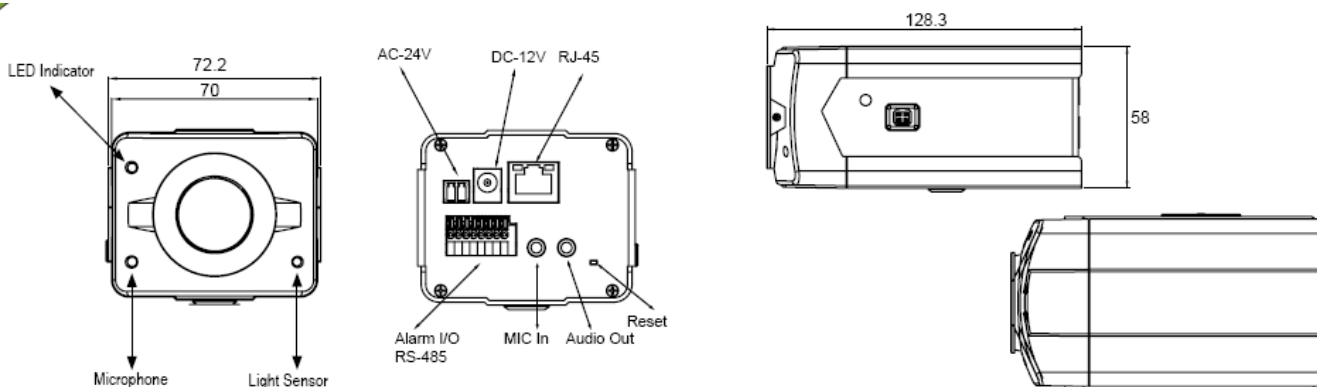

J-CAM Network Cameras

J-CAM OC Outdoor Camera

The J-CAM OC is designed as a cost-effective surveillance system with progressive scan video that allows triple video streams to be simultaneously delivered in different configurations for individual recording or bandwidth and storage demands. The J-CAM OC features an IP66 rated waterproof housing and is suitable for use both indoors and outdoors.



The camera also comes with a range of features such as mechanical IR cut filter and PoE, and as such are suitable for a variety of IP video environments.



Key Features

- Supports H.264, MPEG-4 and MJPEG triple codec compression with multiple streams
- 1.3 Megapixel resolution
- CS mount 6mm / F1.8 megapixel fixed lens with IR cut filter correction
- Day & night function with mechanical IR cut filter
- Supports two-way audio
- Built-in SD/SDHC card slot for local storage
- Built-in 802.3 as compliant PoE
- Supports ONVIF standard to ensure interoperability
- IP66 rated waterproof housing

The included management software allows users to monitor up-to 16 cameras from one location, on a single screen via a simple and intuitive interface.

Specifications

| | | |
|----------------------------------|------------------|--|
| Model Name | | J-CAM OC |
| System | | Embedded Linux, ARM-based 32-bit RISC Processor, 16mb Flash ROM 126mb DDR |
| Video Compression | | H.264, MPEG4, MJPEG |
| Video Resolution | | SXGA (1280x1024), HD720 (1280x720), VGA (640x480), QVGA (320x240), QQVGA (160x120) |
| Frame Rate | | Up to 15fps @ SXGA / Up to 30fps @ HD720, VGA, QVGA, QQVGA |
| Image Sensor | | 1/2.7" progressive scan CMOS sensor |
| Lens | | CS Mount, Fixed Iris, Focal length 6.0mm, F1.8 |
| Minimum Illumination | | 0.5 Lux / F1.8 |
| Image Settings | | ICR for day and night vision |
| | | AEC, AWB, BLC, Brightness, Contrast, Saturation, Sharpness |
| | | Flip, Mirror |
| | | OSD Timestamp & Text Caption Overlay |
| Event Management | Triggers | Motion Detection, Digital Input, Manual Trigger |
| | Actions | Digital Output, Notification via Email, FTP or SD, Snapshot |
| On-board Storage | | n/a |
| Network | Interface | 10/100 Base-T Ethernet |
| | Protocols | IPv4, TCP/IP, HTTP, HTTPs, UPnP, RTSP/RTP/RTCP, IGMP, FTP, DHCP, DNS, DDNS, PPPoE, NTP, SMTP |
| Audio | | Built-in Mic, External Mic In, Audio Out |
| Power Supply | | DC12V/2A |
| | | AC24V |
| | | PoE 802.3af Compliant |
| Operation Temperature | | -10 ~ 50 °c |
| Operation Humidity | | 20% ~ 80% RH |
| Dimensions (L x W x H) | | 84.9mm x 179.92mm |
| Weight | | 906g |
| Client System Requirement | | OS: MS Windows 7 / Vista / XP / 2k, Browser: IE 6.x or above |

