

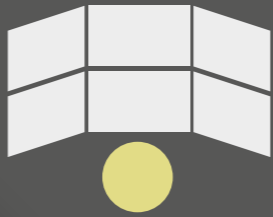





# advantis

E V O L U T I O N

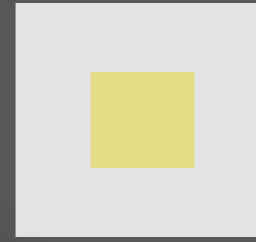

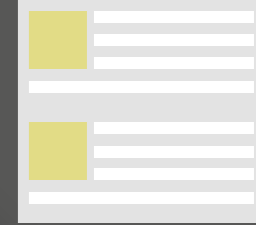
# ↓ Contents

	High added value 6	10 ↑ Take control	18 Advantis around the world ↑		50 → Human factor
↓ The Console 2					52 Environment →
	Precision 8		Differentiation 22 ↑		
Global model 4		→ The system 12			Modularity ↓ 54

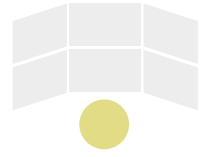

# The Console

Observe, investigate and design. Test and refine. An on-going work process in which our engineers and designers have created a dynamic, decisive and flexible way of thinking. ADVANTIS has evolved into a model of innovation and functionality, of naturalness and precision.



# Global Model

Experience in the search for perfection. And so ADVANTIS has thrived, the technical console for control and decision-making centres which has set the market trend, culminate in a single elegant and solid model.



# High added value

ADVANTIS is synonymous with ergonomics, control, functionality, connectivity, design and quality. A console concept which drives changes in technological environments with high added value.





# Precision

ADVANTIS adjusts perfectly to every need, to every work environment and to every technical specification thanks to the many possibilities it offers. A console which adapts to people in every way.



# Take Control

The ADVANTIS series responds efficiently to any demand 24/7. Its versatility provides solutions for all technological environments and departments: control and operations centres, administrative rooms, crisis units, meeting rooms, conference centres, etc.

Its ergonomic design means that any activity can be carried out comfortably and precisely. People are our priority and ADVANTIS sits in the centre of their existence, putting their needs first and providing a unique experience where everything is under control.



# System

Available and ready for use from the beginning. Absolute flexibility to adapt to any environment and to any user. Shapes created by people and for people. ADVANTIS is a leading product in the organisation of technical departments with unlimited configurations, clearly differentiating the space needed for the IT systems from the space for the user.









# Advantis around the world

ADVANTIS's characteristics have made it an internationally recognised console. A sure bet for all solutions.

Years of experience and its use in various facilities throughout a wide range of sectors around the world place ADVANTIS at the top of the market for technical consoles in control and decision-making centres.

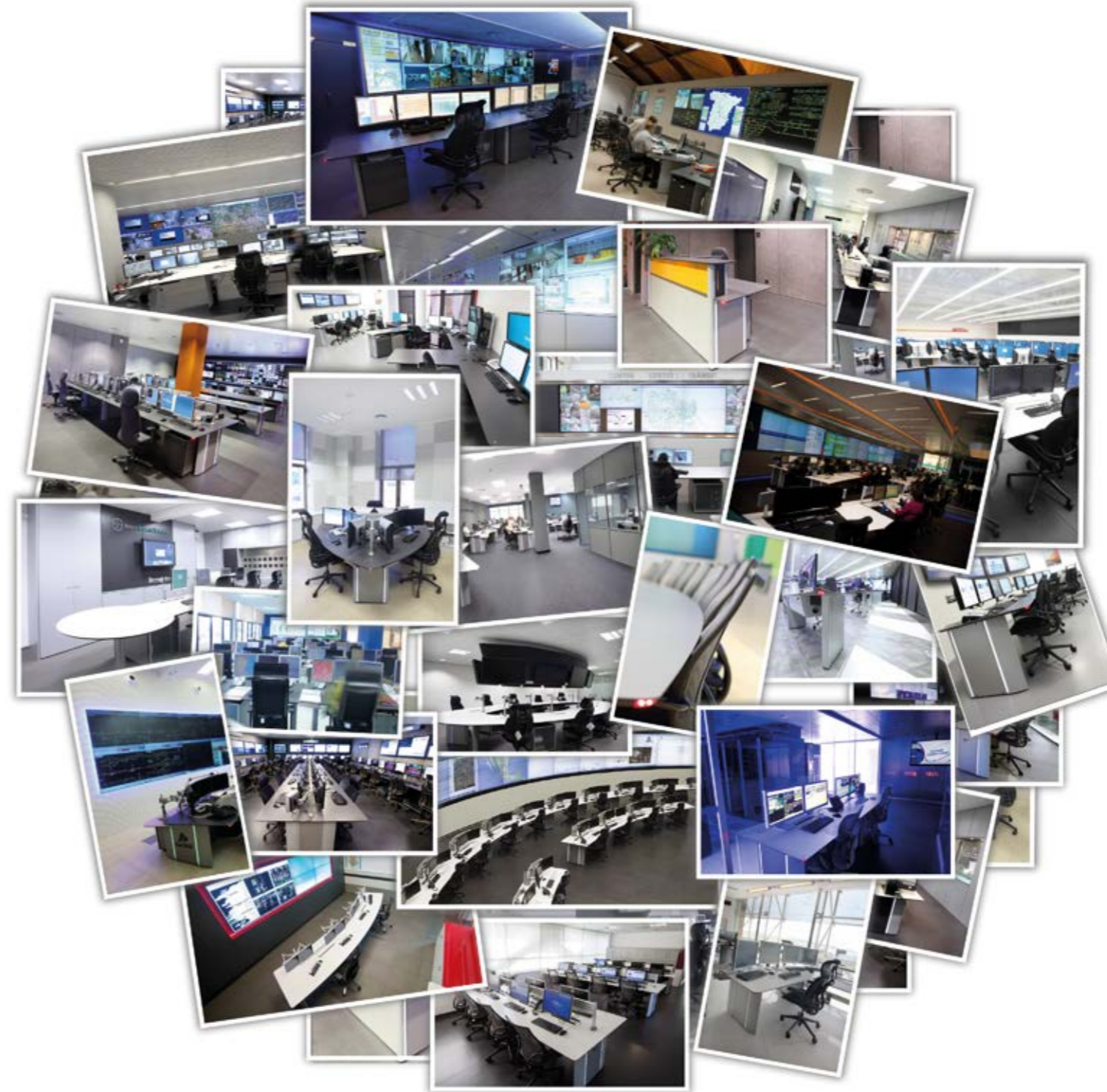



# Global Concept





# Differentiation

Being unique requires us to forge our own path, abandon work done by others and go back to the drawing board. We make the effort to surpass ourselves once again, to be different. And we have managed it.

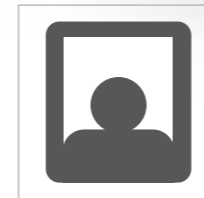
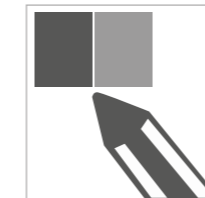
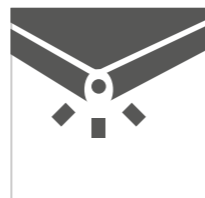
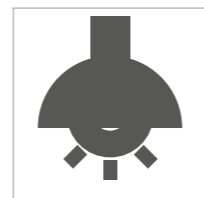
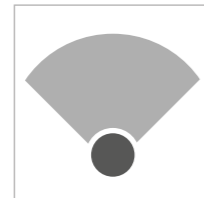
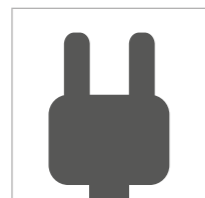



# Structural Beam

The central nerve system of the structure. The central axis of all connections. Designed to store the cables, allowing linear and curved configurations to be used. Unlimited.





All ADVANTIS series accessories are specially designed to work together as well as possible, offering a wide range of products on a design and functionality base.



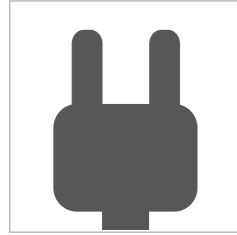

# Connectivity

ADVANTIS combines the four techniques required for organising and managing all the cabling and connections: surface connections, Technical Service Area (TSA), mains connections and cable runs. Maximum connectivity. Optimal ergonomics.





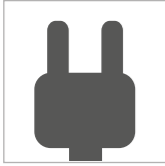

Technological demands market changing needs over time. ADVANTIS adapts perfectly to any variation, allowing for immediate access to and control of IT systems installed in any configuration, taking care of cabling and other corresponding connections.



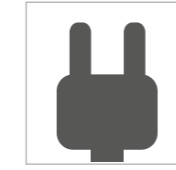

People and technology. A perfect blend. The Personal Technical Area (PTA) clearly divides the space for the IT systems from the space for the user.



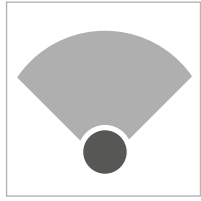

# Visual Ergonomics

A key factor offered by ADVANTIS in the design of a console and the conceptualisation of a 24/7 control centre is different ergonomic stands for monitors and a visual ergonomic inspection of the operation to ensure an increase in work quality and health of users.





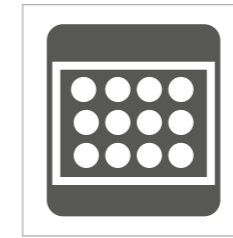

# Compartments

Good quality and long-lasting. Structure made in aluminium with quick, comfortable and safe access for managing cabling and connections to equipment installed with ventilation. Elegant and sturdy in one single concept.



Multiple configurations: with drawers, individual, double or triple, which adapt perfectly to any need. Between the compartments, a Technical Service Area can be created, optimising the ventilation of equipment through a collapsible aluminium grille. Its versatility means it can also be used as auxiliary furniture. Diversity of functions in a single concept.

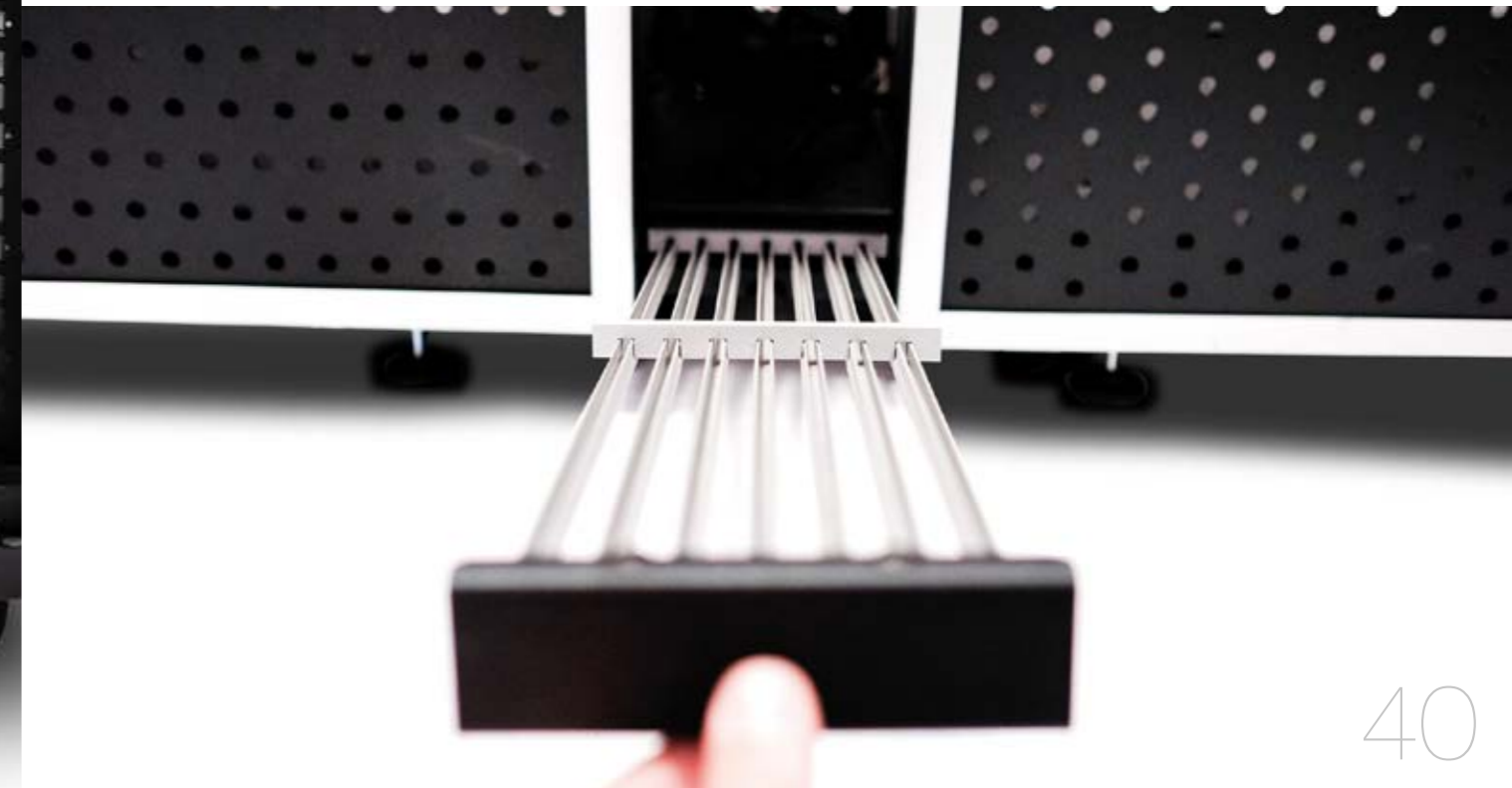

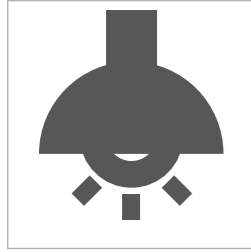

# Customisation

ADVANTIS is transformation. Change. Flexibility to adapt to any project. The perfect metamorphosis, infinite permutations.



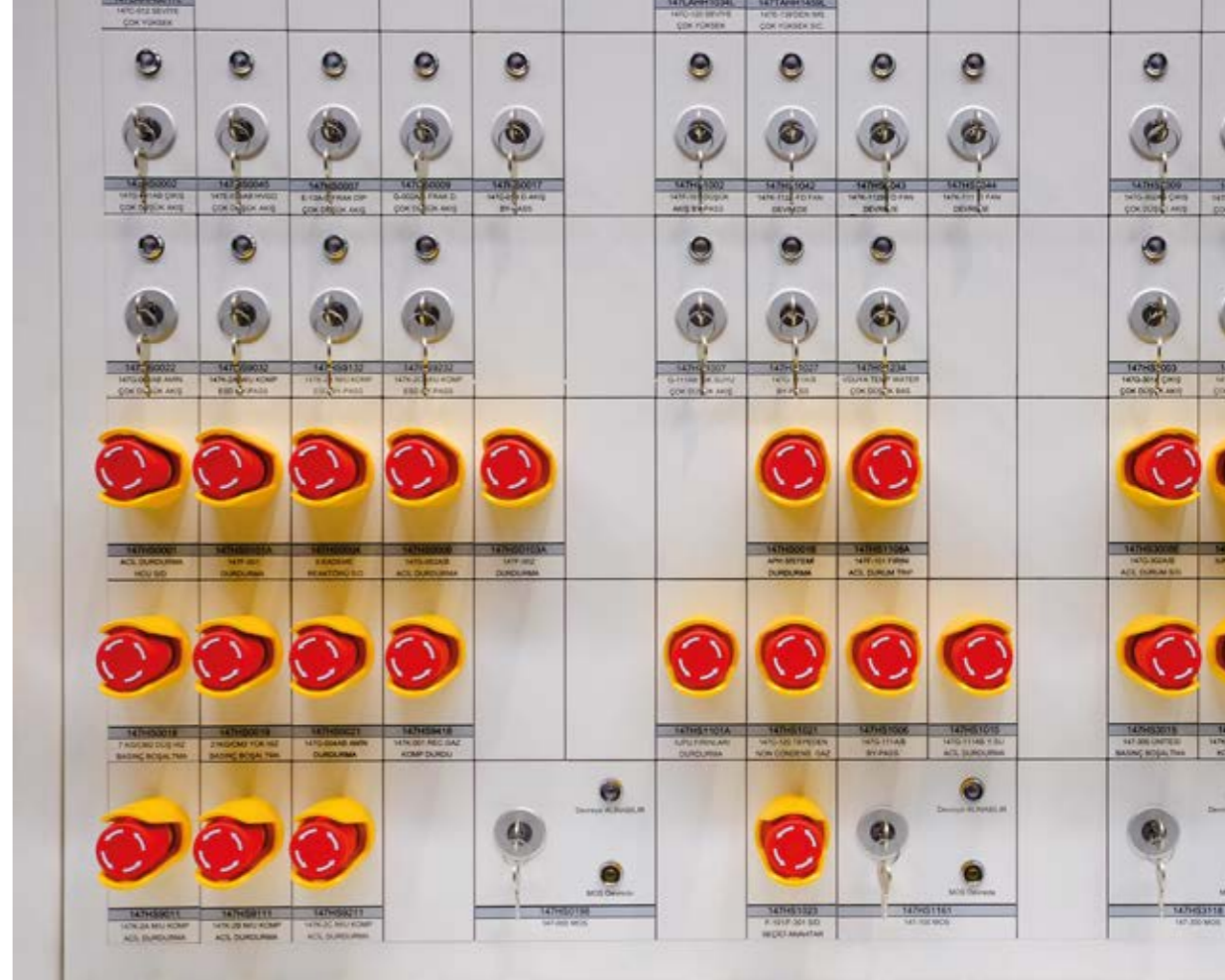
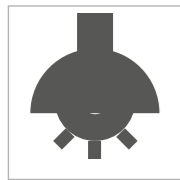



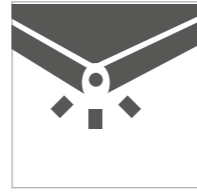

# Safety

At the end of each line, there is an LED illumination system. The colour red locates and signals console protrusions, complemented by side lighting which indicate corridors and evacuation routes.

Functionality, safety and design. Elements which make us unique. GESAB exclusive solutions.



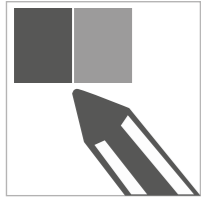

# Finishes

These spaces combine with each person, providing optimal conditions for demanding technical environments. Work surfaces are made of high-quality compacted phenolic which is subjected to rigorous testing and certifications by top agencies. Available in four basic colours: white, light grey, anthracite grey and beech, offering the possibility of optional customisation in terms of design, finishes and colours.

## advantis STANDARD METALLIC COLORS



Anthracite



Metallic gray

## FUNDERMAX

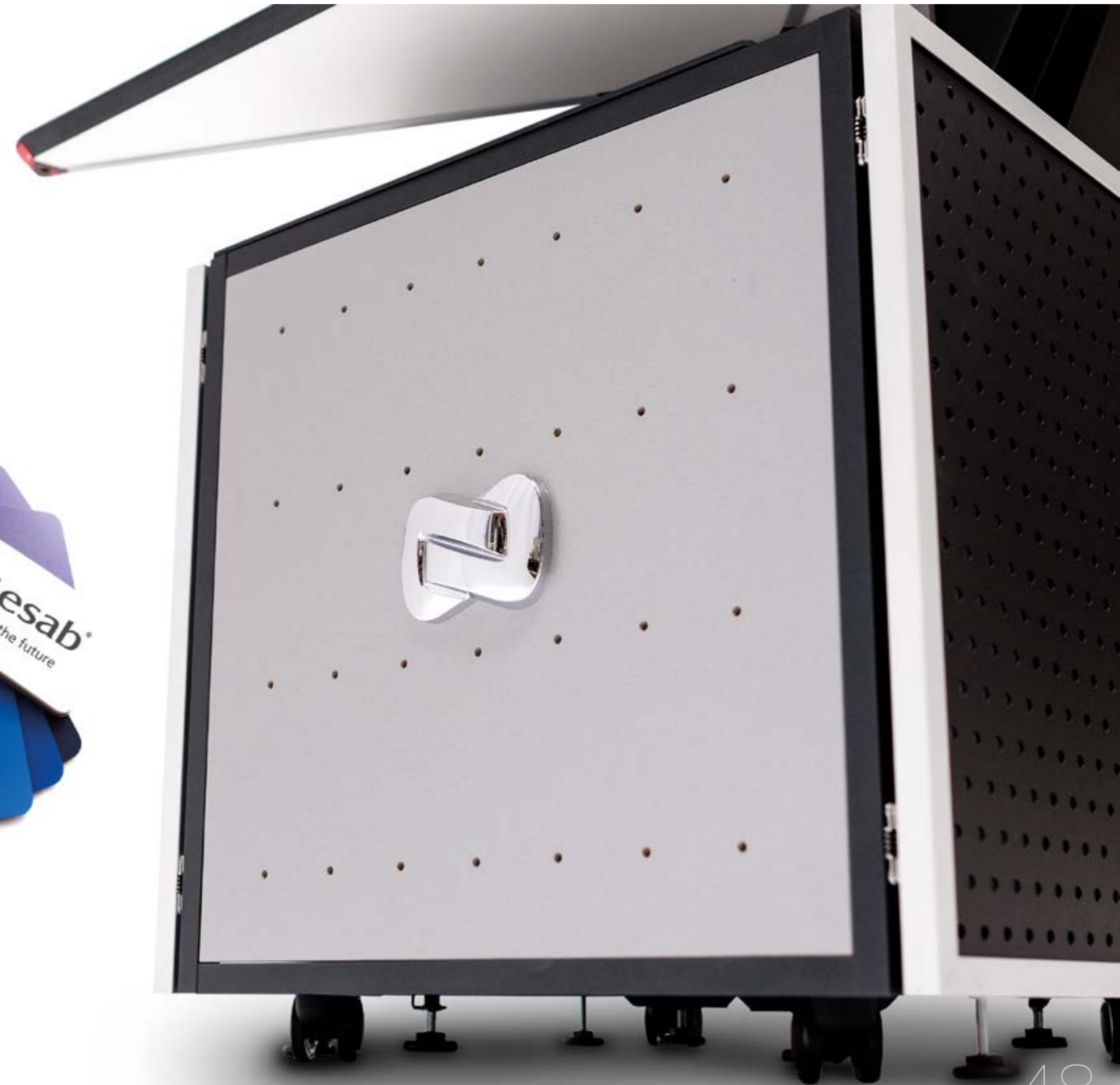



# Human factor

Health, comfort and productivity. These are the three factors which guide our designers following ISO 11064-3 regulations and which have provided ADVANTIS with UNE-EN 527-2011 certification. They define the dimensions and layout of the work surface which then adapt to the user's postures while working. Up to 65% more space than in traditional furniture.

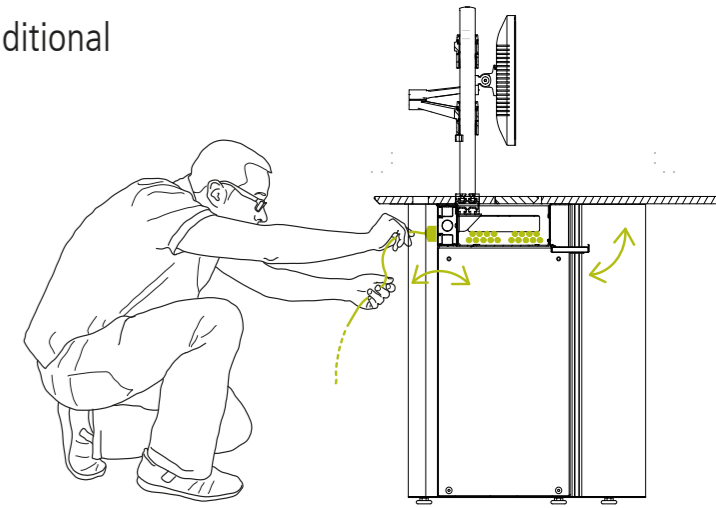

- SECCIÓN HUECO PIERNAS UNE-EN 527-2011
- ESPACIO EXTRA ADVANTIS EVOLUTION

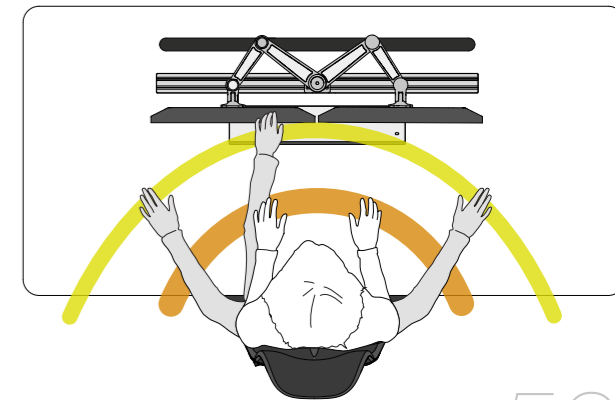
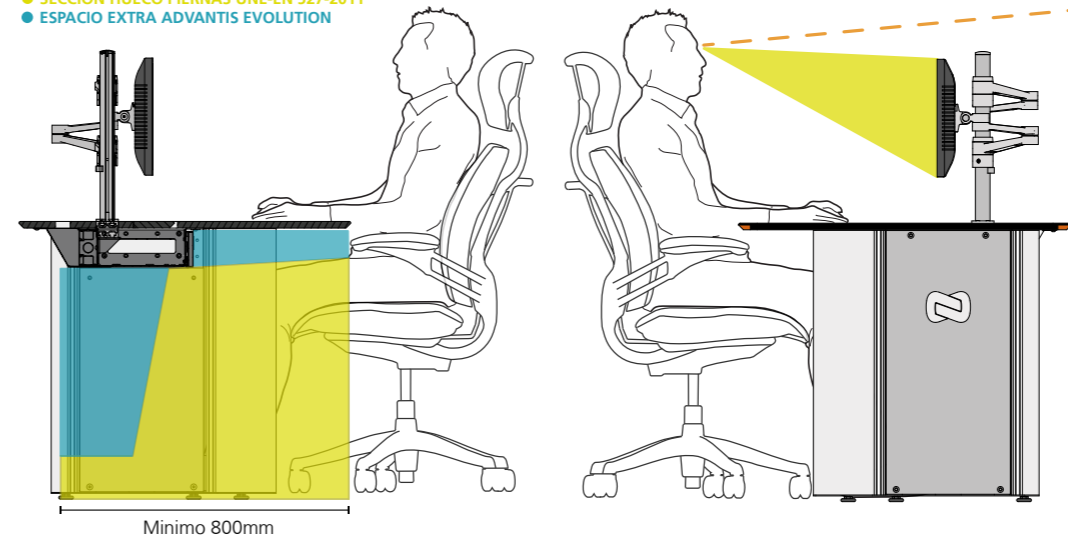



# Environment

GESAB creates its products and solutions with a global, sustainable and forward-looking mentality. We design, manufacture and assemble while bearing in mind the limited resources of the planet.

For this reason, ADVANTIS is made up of highly-recyclable materials which guarantee a longer lifespan for the product. This selective recycling process starts upon disassembly after its lifespan is over.



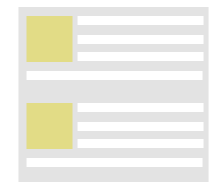
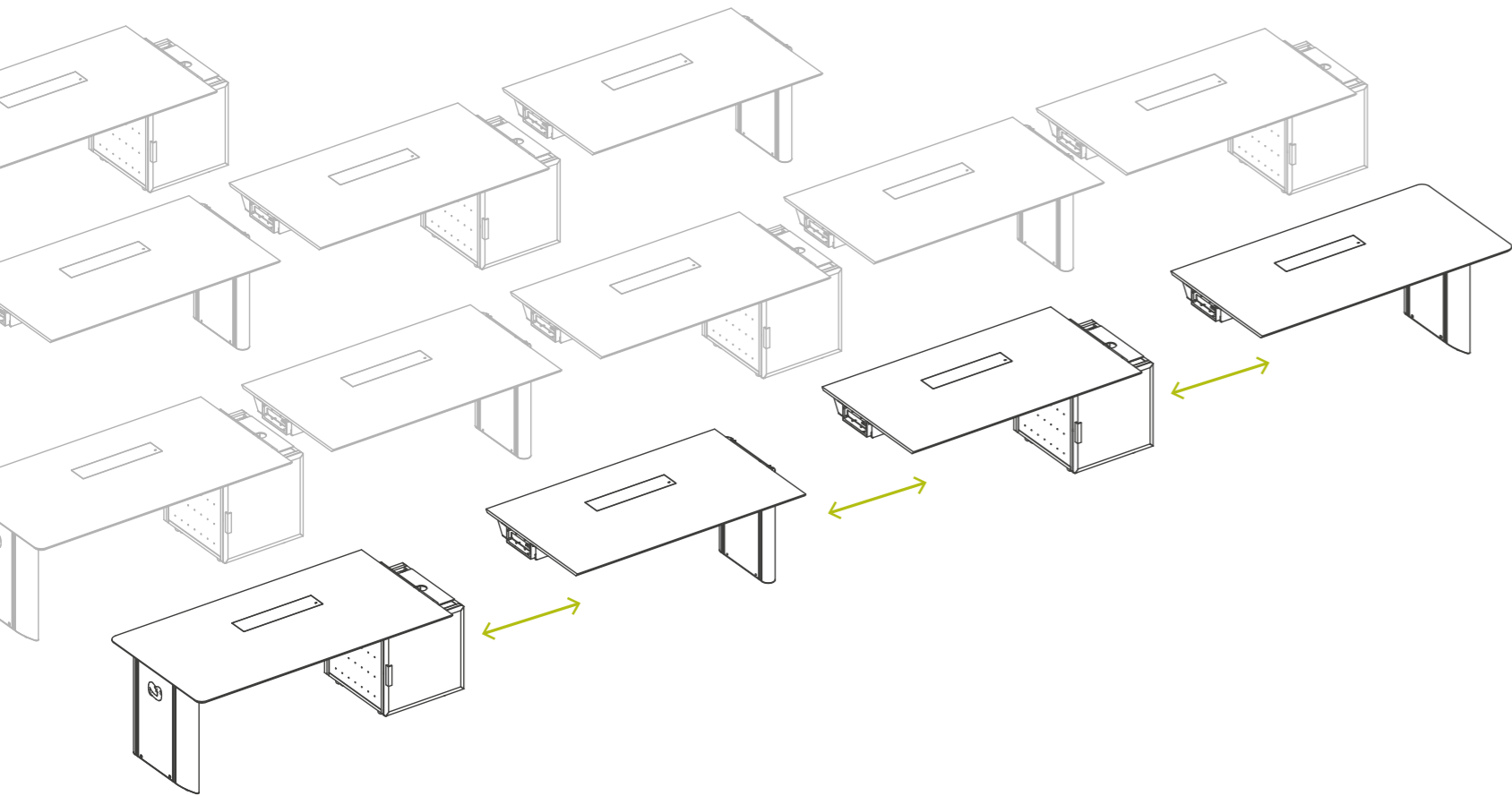

# Modularity

ADVANTIS EVOLUTION was created both as a part and as a whole. It can be an individual or a collective solution and take on various forms and quantities: concave, convex, semi-circular. The grade generator system allows us to create made-to-measure solutions for any environment and need.

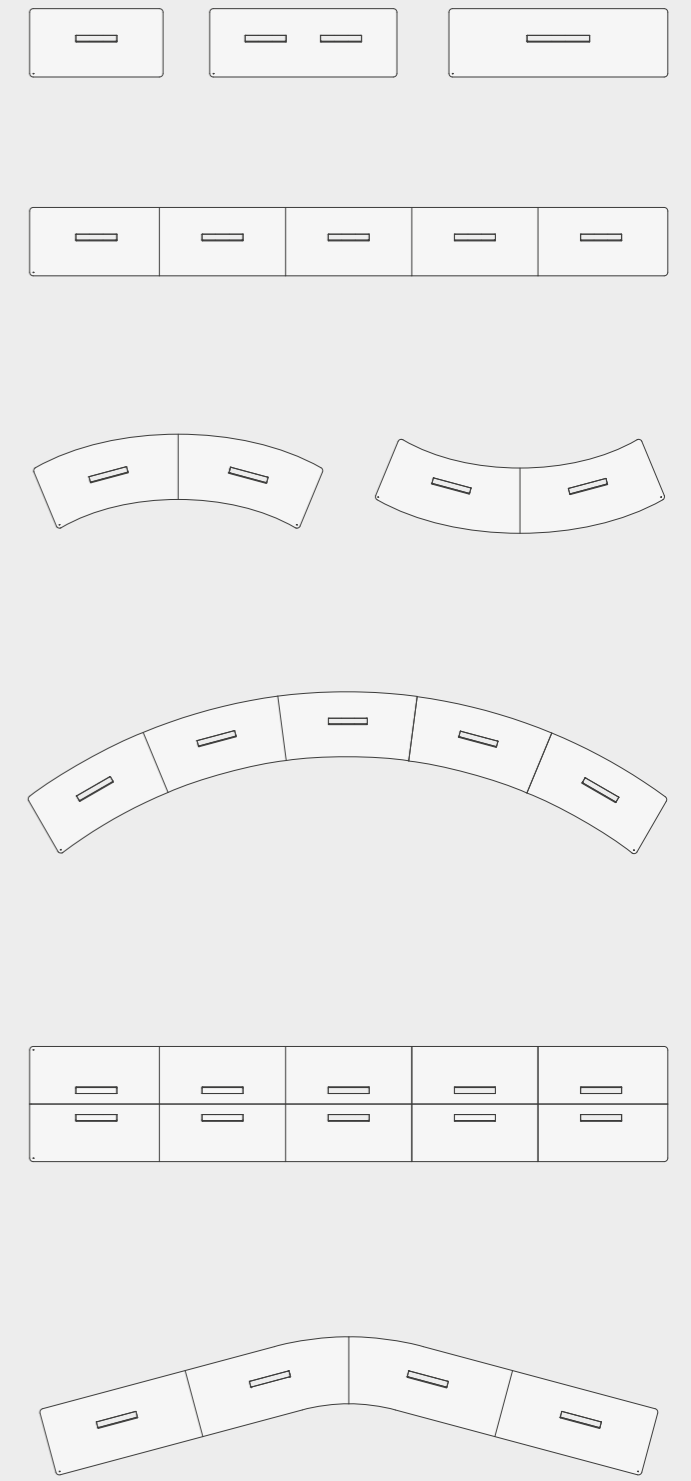
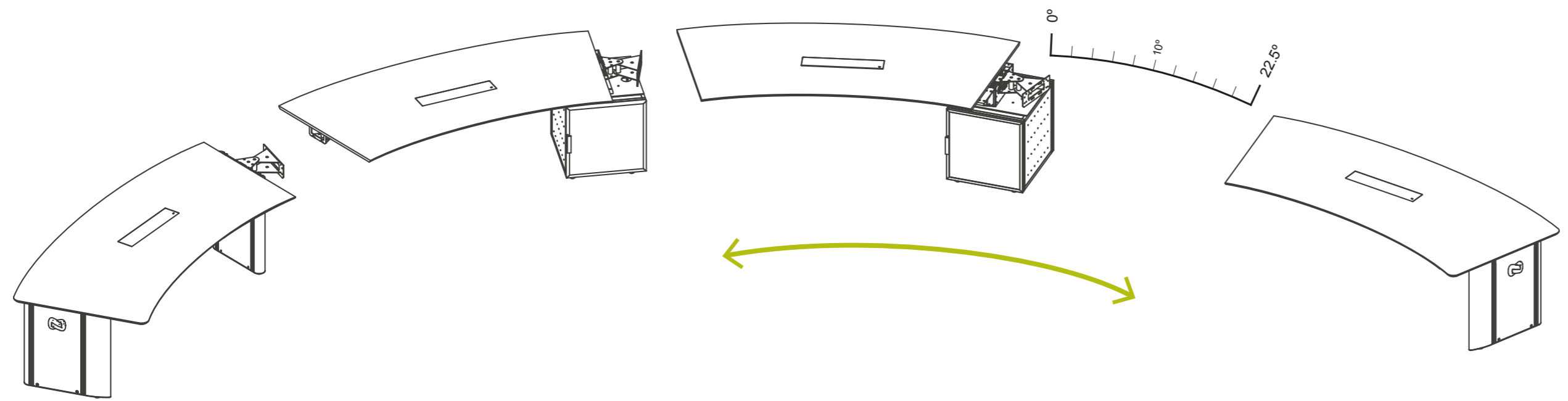

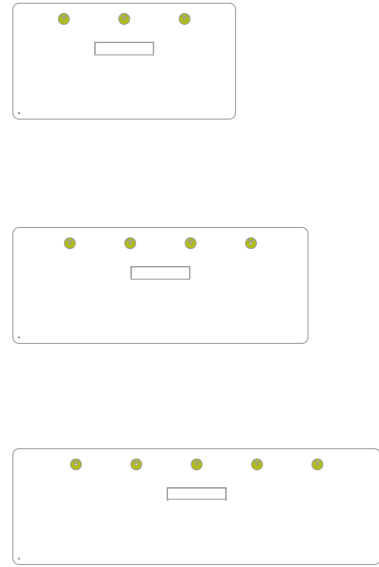

**BOLT SYSTEM**

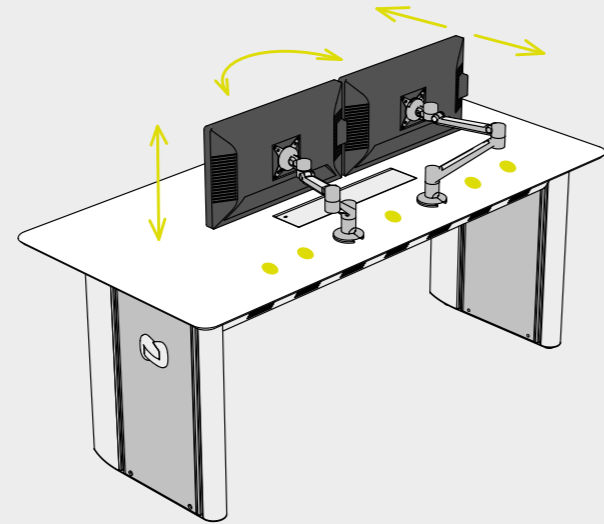

Standard arm system without width regulation.

**ACCESS RAIL SYSTEM**

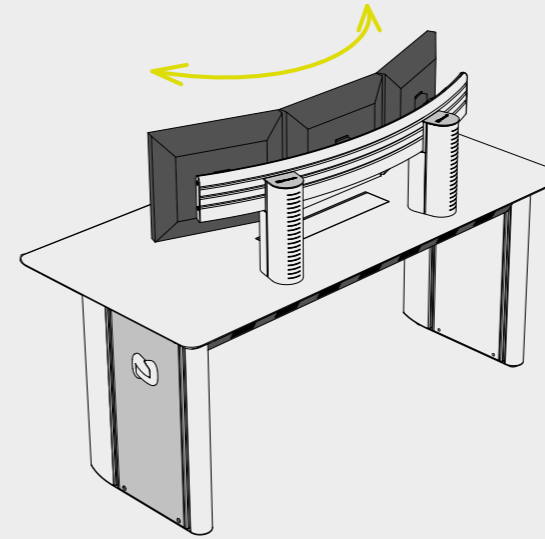

Access Rail profile system without cable management included.

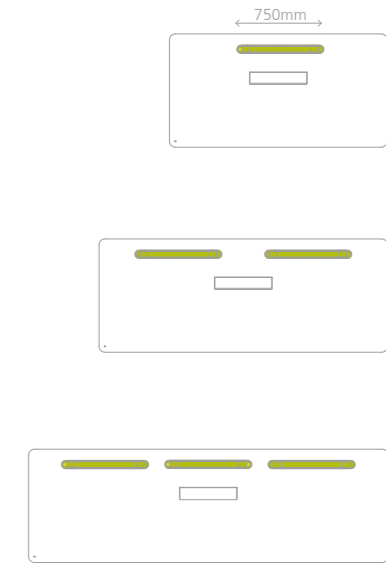

**GESAB ACCESS RAIL SYSTEM**

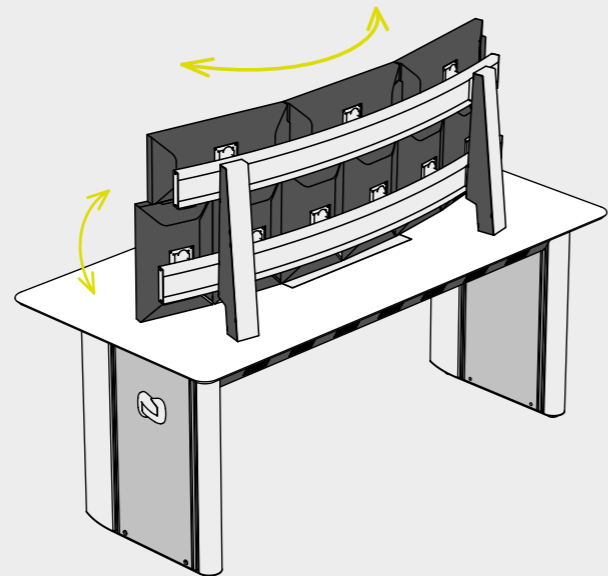



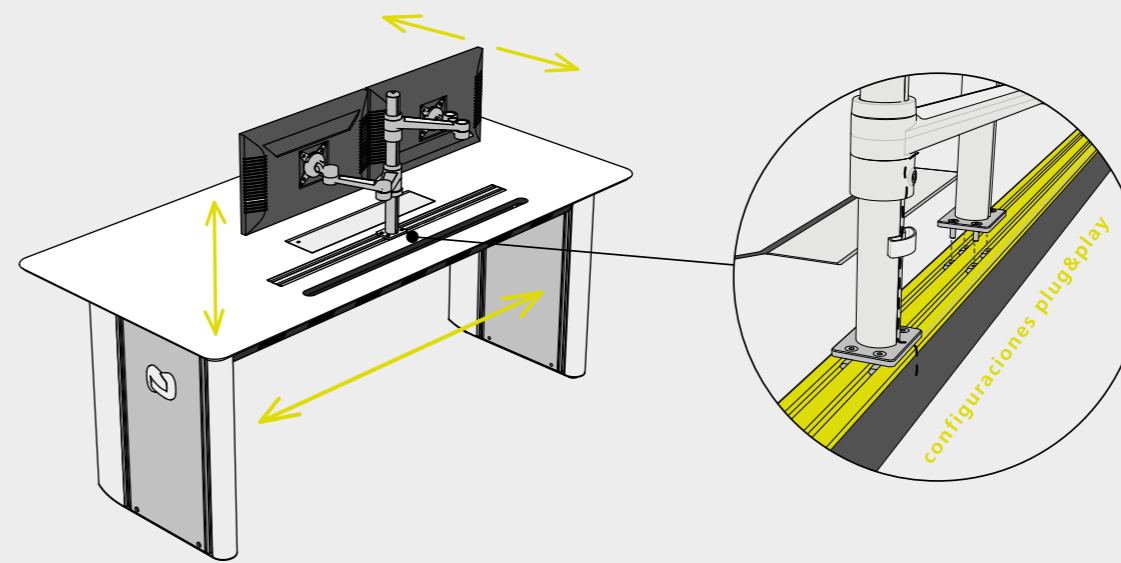

Profile system for organisation of GESAB monitors with cable management included.

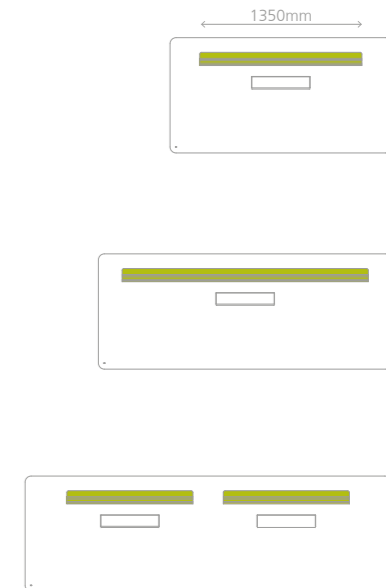

**WI-RAIL SYSTEM**

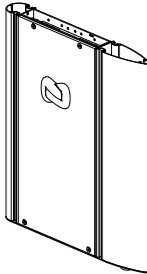
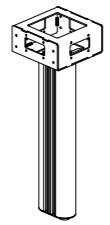
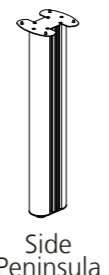
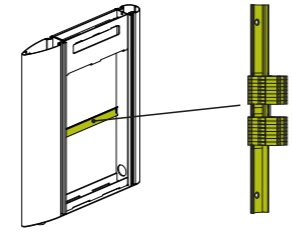





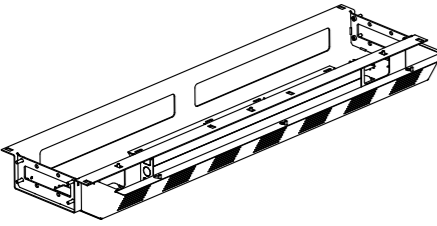
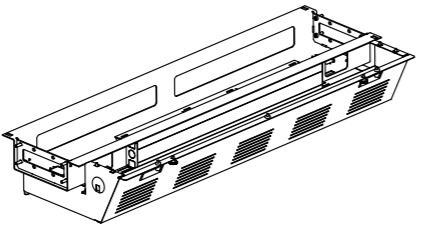

Regulation system using aluminium rail on work surface.

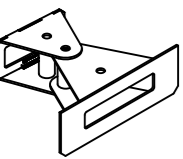
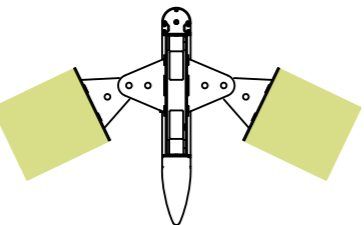
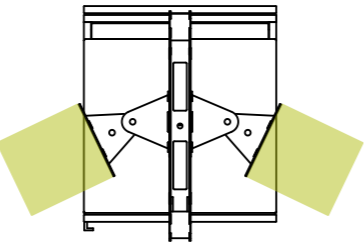



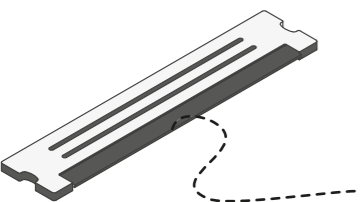
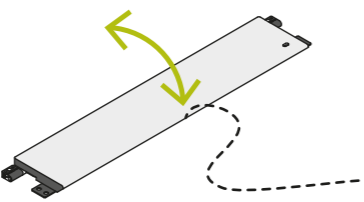



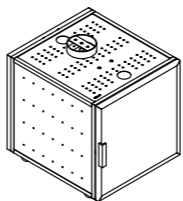
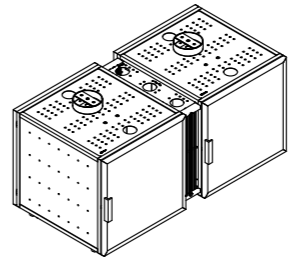
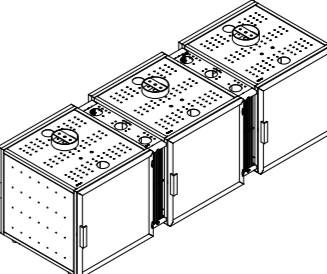

SIDES	Model	OPTIONS	ACCESSORIES	Material / Finishes
	Extreme Intermediate Tradding Meetings Sit & Stand	 Side distributor  Side Peninsula	 Quick connection terminals	Plywood Covers Finish Titan   Profiles Vertical Painted Aluminium   Steel Chassis Steel Channels 



EVOLUTION BEAM	EVOLUTION KVM BEAM	Models	Material / Finishes
		800mm 1000mm 1200mm 1400mm 1600mm 1800mm 2000mm 2200mm	Connection channels Aluminium An.   Steel Chassis Black Epoxy Paint 

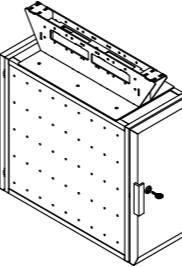
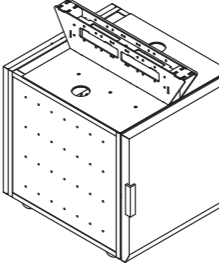
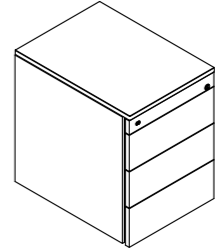

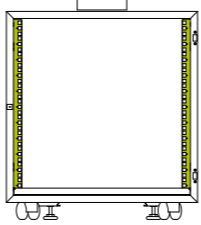
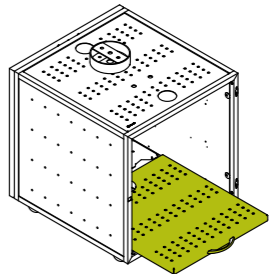

GRADE GENERATOR	Model	GENERATOR OPTIONS	Material / Finishes
	0°-90°	 Side Grade Generator  Buck Grade Generator	Steel Generator Black Epoxy Paint 

RECORDABLE PERSONAL COVER	PIVOTING PERSONAL COVER	Model	Material / Finishes
		550mm 700mm Model USA	White Phenolic Surface   Anthracite Phenolic Surface   Special Phenolic Surface *Consult 

INDIVIDUAL BUCK	DOUBLE BUCK	TRIPLE BUCK	Material / Finishes
			Plywood Covers Finish Titan   Profiles Vertical Painted Aluminium   Steel Chassis Steel Channels 

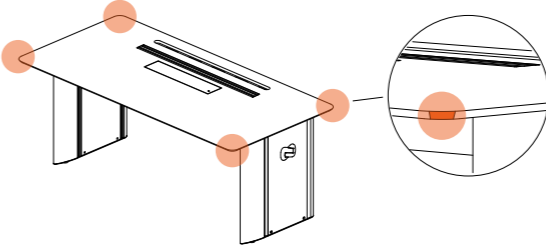
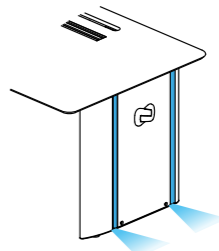
STRUCTURAL BUCK 300	STRUCTURAL BUCK 550	DRAWERS	Material / Finishes
			Plywood Covers Finish Titan   Profiles Vertical Painted Aluminium   Steel Chassis Steel Channels 

ACCESORIES BUCK:	Models	REMOVABLE TRAY	CUPHOLDER
	10u 7u 4u 3u		

SAFETY	OPTIONS	Material / Finishes
	 Corner LED Safety System  Side Illumination	Red illumination   White illumination   Blue illumination 



ADVANTIS is protected by international patent, community model and property laws Intellectual and copyrights.

GESAB is the owner of these designs, protected by Spanish and international laws. All property rights on any intellectual content of this document were reserved for his exclusive use by GESAB, during all their legal life.

It is understood among those rights, by way of example and not limitation, any property rights intellectual patent records, texts, images, drawings, color combinations, button icons, brands, logos, slogans and designs, as well as on the structure, design, selection, arrangement and presentation of any information and / or contained herein.

It is expressly prohibited, in any case, the reproduction, copying, publication, distribution, modification, deletion, manipulation and any other use, whether or not for profit, all or part of this document or any of its contents, without the prior express by written permission of GESAB.

GESAB reserves the right to modify, change, replace or delete at any time and without notice the contents and information found in this document.

Pictures: GESAB and Antonio Liébana

Design: GESAB

© GESAB, Inc. Copyright 2014. All rights reserved.



Barcelona  
902 113 186  
Avda. del Mogent, 68  
08450 Llinars del Vallès

Madrid  
902 113 187  
Marzo, 61-67  
28022 Madrid

México D.F.  
(+52) 55 1997 0746  
Sófocles, 127 - Polanco  
Del. Miguel Hidalgo (11540 D.F.)

International  
(+34) 915 345 064  
Marzo, 61-67  
28022 Madrid

[www.gesab.com](http://www.gesab.com)





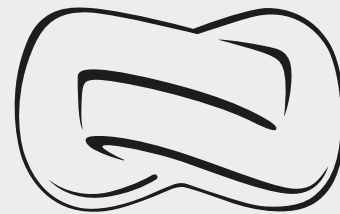

advance GESAB